



# THANK YOU!

---

You have successfully downloaded your *Woodsmith* project plan.

▶ [Go to Page 1](#)

## **Get More from Your Table Saw...at PlansNOW.com**

---



### **Build our 10 BEST Table Saw Jigs!**

What really makes a table saw so versatile are the jigs and accessories that improve your saw's overall performance.

▶ [Download Today at PlansNOW.com...\\$4.95](#)

## **Woodsmith Shop TV Show Special...Save 10%**

---



### **Use Coupon Code *TVSHOW* at PlansNOW.com**

Visit PlansNOW.com today and save 10% on more than 200 woodworking plans and how-to technique articles.

▶ [Go to PlansNOW.com Now](#)

## **You Can Build It...at PlansNOW.com**

---



### **Workbenches**

Good woodworking starts with a solid workbench.



### **Shop Jigs & Techniques**

Get the most from your tools with easy-to-build shop jigs.



### **Cabinets & Shelves**

Build stunning furniture that's both functional and beautiful.



### **Home Improvement**

Save hundreds of dollars in remodeling when you DIY.



Woodsmith **PLANS**

# COTTAGE DRESSER



# COTTAGE DRESSER

*Beadboard panels, applied moldings, and an “antique” finish give this casual dresser tons of character and charm.*

Some things never go out of style. Take cottage furniture for example. It’s as popular today as it was in the early 1900s when it was first introduced in New England homes. The painted dresser you see here is a good example of what makes this style of furniture so well-liked.

To create a casual look, it’s designed with beadboard panels on the sides and doors (lower right photo), as well as more elegant details like applied moldings wrapped around the top and bottom (left photo below) — two hallmarks of the cottage style. That’s why you’re just as likely to find a dresser like this in a formal mansion as you are in an offbeat, ocean-front getaway.

But it’s the relaxed, worn finish (middle photo below) that says “cottage-style” more than anything. Furniture usually has to age gracefully before it looks like it has been around for generations. I simply hurried it along with a special finishing technique (see page 9).

Besides attractive styling, cottage furniture has another enduring quality — it’s easy to build. Even though this dresser is a large project with plenty of woodworking challenges, it’s still very buildable. The sides and doors are assembled with simple stub tenon and groove joinery. Easy-to-cut tongue and dado joints make for strong drawers, while the moldings are just glued and nailed on.



**APPLIED MOLDINGS**

▲ Simple applied moldings you can make in the shop add an elegant touch, yet still fit well with the more casual beadboard panels.



**ANTIQUÉ FINISH**

▲ Carefully sanding the beads of the panels to “knock off” the paint gives this dresser an old-fashioned antique look.



**BEADBOARD PANELS**

▲ Plywood beadboard panels make assembling the sides easier and add to the cottage charm.

# Construction Details

Overall Dimensions:  
43" x 20<sup>1</sup>/<sub>2</sub>" x 61<sup>3</sup>/<sub>4</sub>"

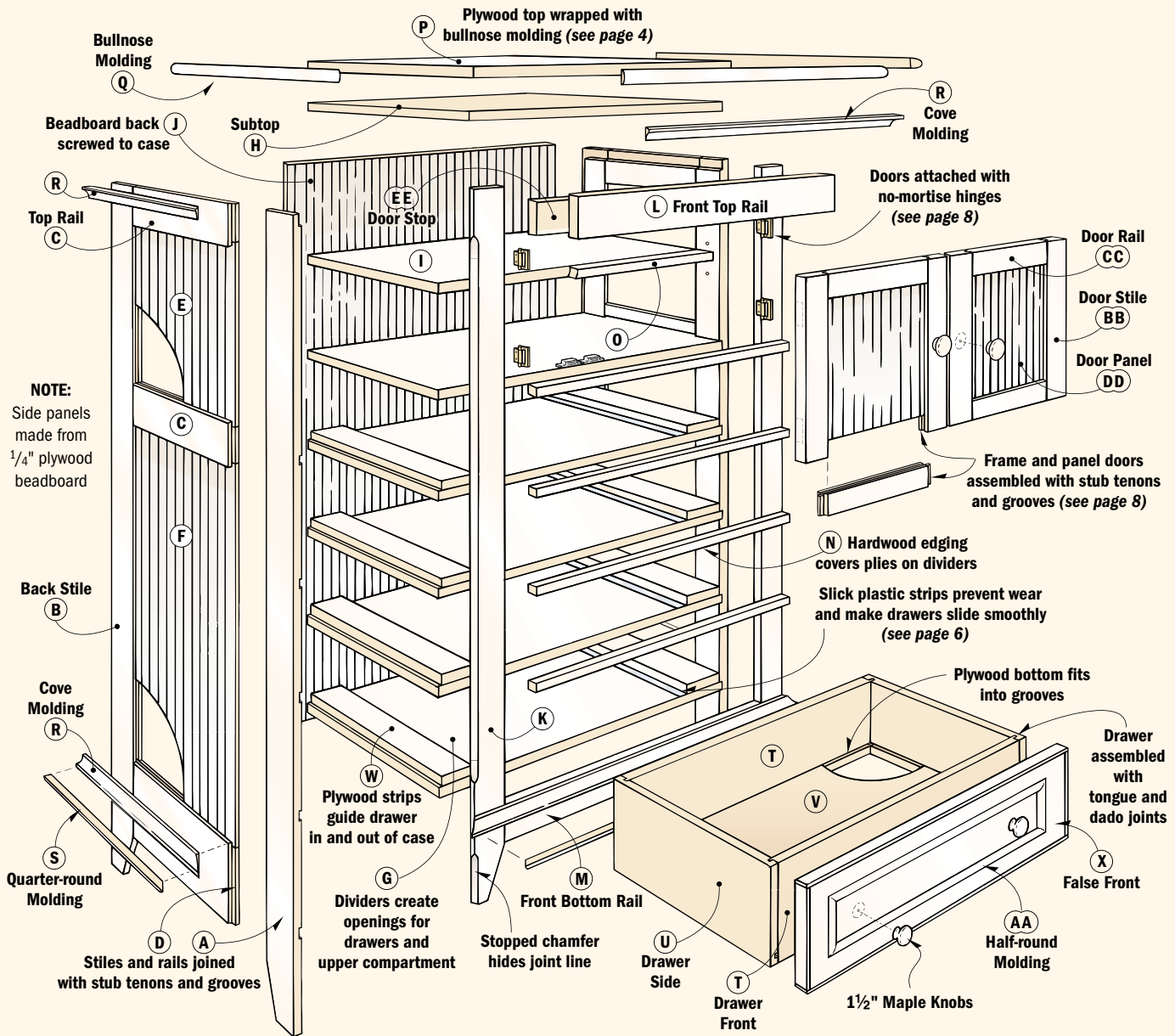

**NOTE:**  
Side panels made from 1/4" plywood beadboard

## MATERIALS

### CASE

- A** (2) Side Front Stiles (birch) 3/4" x 3 1/4" x 61"
- B** (2) Side Back Stiles (birch) 3/4" x 3 1/2" x 61"
- C** (4) Side Top/Mdl. Rails (birch) 3/4" x 3 1/2" x 14"
- D** (2) Side Bottom Rails (birch) 3/4" x 6" x 14"
- E** (2) Side Top Panel (beadbd.) 1/4" x 14" x 14 3/8"
- F** (2) Side Btm. Panel (beadbd.) 1/4" x 14" x 31 1/8"
- G** (5) Dividers (birch ply.) 3/4" x 19 1/16" x 39"
- H** (1) Subtop (birch ply.) 3/4" x 19 1/16" x 39"
- I** (1) Adj. Shelf (birch ply.) 3/4" x 18" x 38 3/8"
- J** (1) Back Panel (beadbd.) 1/4" x 39 1/2" x 54"
- K** (2) Front Face Stiles (birch) 3/4" x 3 1/2" x 61"
- L** (1) Front Top Rail (birch) 3/4" x 2 3/4" x 33"
- M** (1) Front Bottom Rail (birch) 3/4" x 3 1/4" x 33"
- N** (5) Edging (birch) 3/4" x 3/4" x 33"
- O** (1) Adj. Shelf Edging (birch) 3/4" x 3/4" x 38 3/8"

- P** (1) Top (birch ply.) 3/4" x 20 3/4" x 41 1/2"
- Q** Bullnose Molding (birch) 3/4" x 3/4" x 7 1/2 ft.
- R** Cove Molding (birch) 3/4" x 3/4" x 15 ft.
- S** Quarter-Round Molding (birch) 1/2" x 1 1/2" x 7 ft.

### DRAWERS & DOORS

- T** (8) Fronts & Backs (birch) 1/2" x 7 5/8" x 32 5/8"
- U** (8) Sides (birch) 1/2" x 7 5/8" x 18 1/4"
- V** (4) Bottoms (birch ply.) 1/4" x 17 3/4" x 32 5/8"
- W** (8) Drw. Guides (birch ply.) 3/4" x 2 7/8" x 19 1/16"
- X** (4) False Fronts (birch ply.) 3/4" x 7 5/8" x 32 5/8"
- Y** (8) Side Edgebanding (birch) 1/8" x 3/4" x 7 5/8"
- Z** (8) Top Edgebanding (birch) 1/8" x 3/4" x 32 7/8"
- AA** Half-round Molding (birch) 1/4" x 1/2" x 24 ft.
- BB** (4) Door Stiles (birch) 3/4" x 2" x 15 3/8"
- CC** (4) Door Rails (birch) 3/4" x 2" x 13 7/16"

- DD** (2) Door Panels (beadbd.) 1/4" x 13 7/16" x 12 3/8"
- EE** (1) Door Stop (birch) 3/4" x 2 1/4" x 38 1/2"

### HARDWARE

- (10) 1 1/2" Maple Knobs
- (8) #8 x 2" Fh Woodscrews
- (44) #8 x 1" Fh Woodscrews
- (8) #8 x 1 1/4" Fh Woodscrews
- (2) #8 x 1/2" Fh Woodscrews
- (2) Magnetic Catches/Strike Plates w/Screws
- (4) 2" Brass No-mortise Hinges w/Screws
- (4) 1/4" Shelf Supports
- (8) 1/2" x 19 1/16" UHMW Drawer Glides
- (8) 1"-long Brads

## SIDE PANEL VIEW

### Begin with the Sides

The case of this dresser starts out as two side panels. Each side consists of a hardwood frame that surrounds two beadboard panels.

**FRAME.** There's nothing complicated about the frame — two stiles and three rails joined with stub tenon and groove joints. I planned on painting the dresser from the start, so I wanted a smooth, dense wood that was relatively inexpensive. That's why I chose birch for the frame. Poplar or maple would be good choices, too.

An important thing to keep in mind as you're cutting the frame pieces is that the front (A) and back (B) side stiles are different widths (Side Panel View). The reason is that when you overlap the side panels with the face frame stiles later on, all four stiles will appear to be the same width.

**GROOVES.** Once the stiles are sized, the next step is to cut a centered groove in the inside edge of each piece. This groove is sized to fit the 1/4" plywood beadboard panels, as well as the stub tenons in the rails (Stub Tenons & Grooves drawing).

**BACK RABBET.** To hold the back panel, you'll also need to cut a rabbet in the long edge of the back stiles (Top & Back Rabbets drawing).

**LEG TAPERS.** Then to complete the stiles, I tapered the bottom of the inside (grooved) edge with a band saw. Notice the "foot" of the front stile is narrower than the back stile (Leg Taper Detail). Again, this will produce a consistent look when the dresser is assembled. The taper also exposes a small part of the groove in the stile, which I filled with a scrap piece, then planed and sanded it flush.

**RAILS.** The side panels are designed with narrow top and middle rails (C) and a wide bottom rail (D). Regardless of width, a stub tenon on both ends is cut to fit the grooves in the stiles (Tenon & Groove Detail).

**BEADBOARD PANELS.** Now it's time to add the beadboard panels. When cutting the panels (E, F) to size, the goal is to trim both edges so you end up with a symmetrical panel (see Beadboard

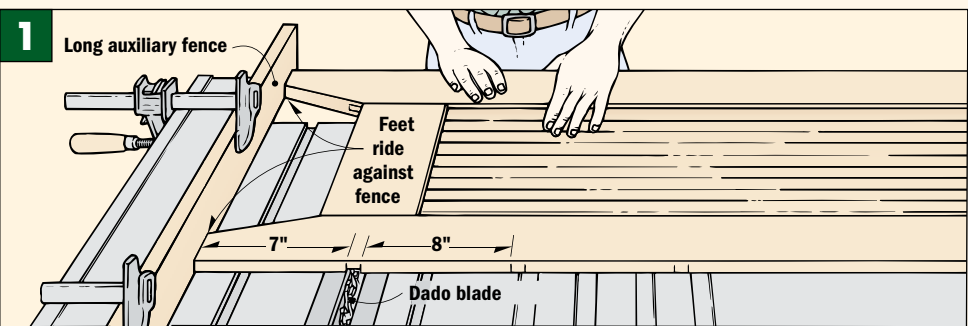
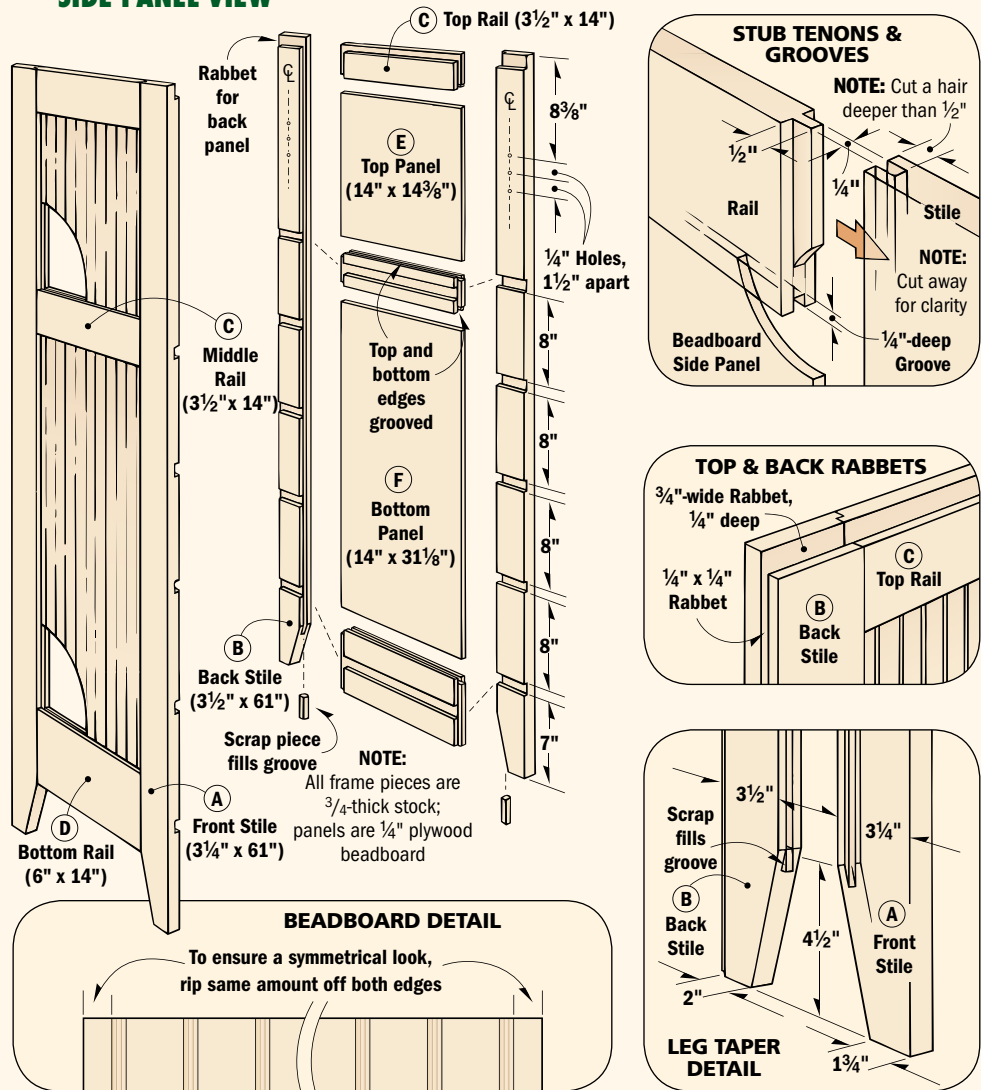

Detail). The panels are then glued into the frame for strength.

**DADO CUTS.** The next step is to cut dados across the inside faces of the sides. They support the plywood dividers that form openings for the drawers. You'll also need a rabbet along the top edge for a subtop (Top & Back Rabbets drawing). To cut the rabbet and dados, install a stacked

dado set in the table saw (shimmed to match the thickness of 3/4" plywood), then raise it 1/4" (Fig. 1a). Next, attach a long auxiliary fence that extends past both ends of the rip fence. This provides a continuous surface for the legs to ride against all the way through the cut.

Now to complete the side panels, drill 1/2" holes in all four stiles for the shelf pins (Side Panel View).

## CASE CONSTRUCTION VIEW

**DESIGN NOTE:** Adjustable shelf must be installed before back panel (J), otherwise it won't fit into the case.

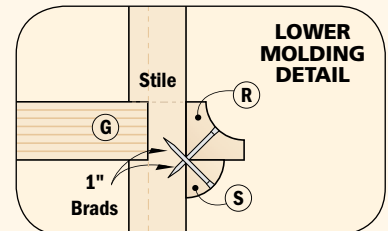
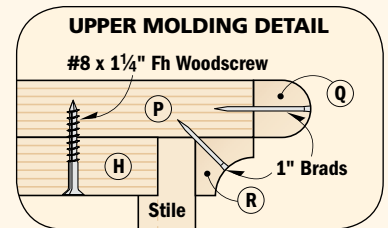
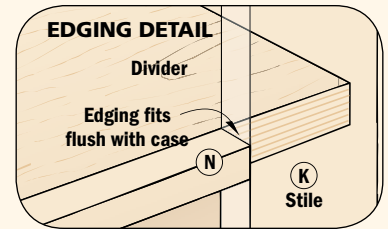
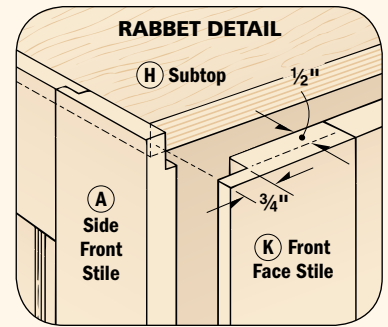
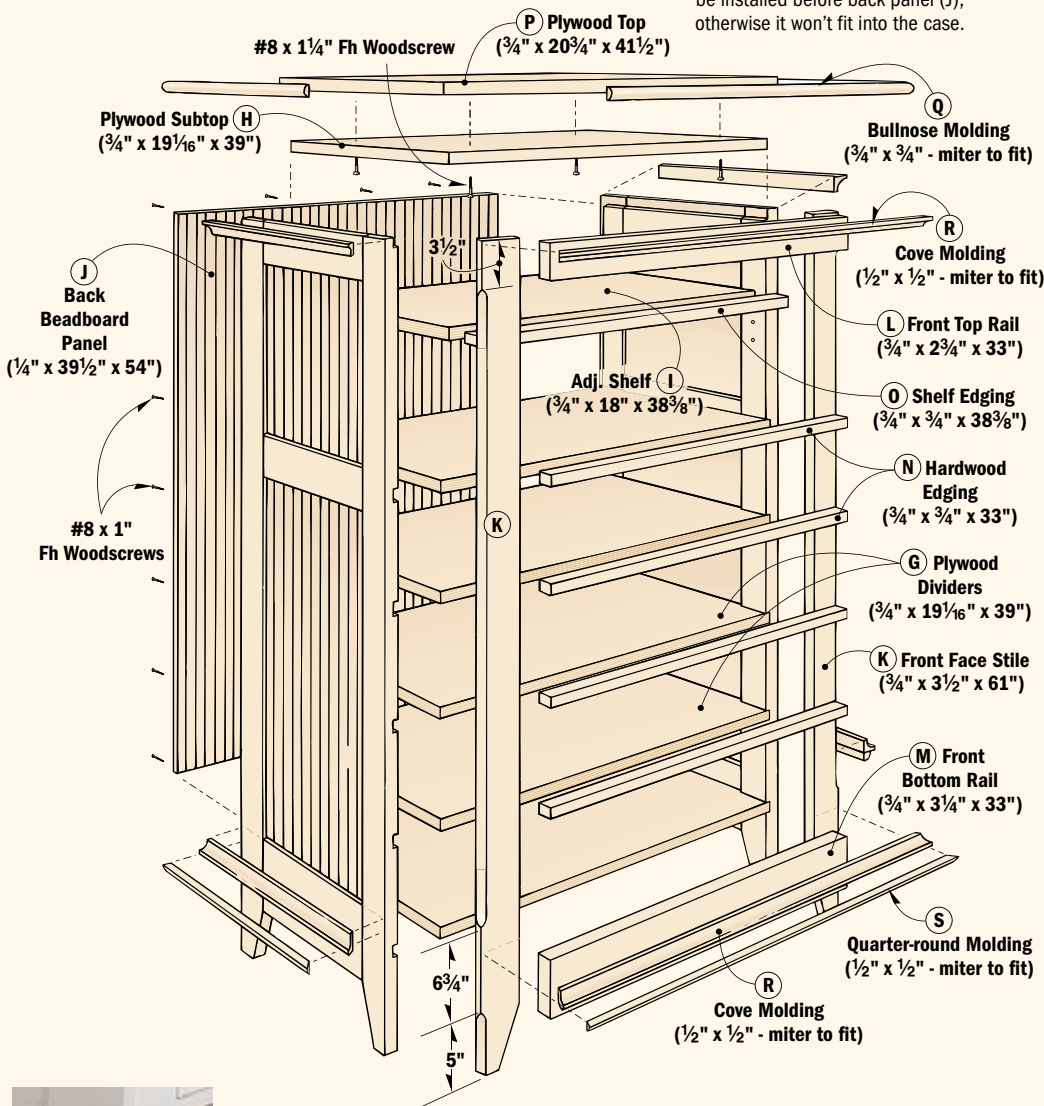

1/4" Stopped chamfers

## Continue with the Case

Before getting started on the rest of the case, take a minute and study the Construction View above.

Notice that several large panels (five dividers and a subtop) form the openings for the drawers, as well as an upper compartment that holds an adjustable shelf. A face frame and decorative moldings are applied to the front and sides of the case. And a dresser top and beadboard back complete the basic unit.

**DIVIDERS & SUBTOP.** The first step is to cut the dividers (G) and subtop (H) from 3/4" plywood. All of these pieces are identical in size. While you're at it, cut the adjustable shelf (I) to size. Note: The shelf is smaller than the dividers and subtop.

**ASSEMBLE CASE.** As with any large project, assembling the case can get hectic. So to make it more manageable, I cut the back (J) from 1/4" plywood beadboard and used it to help square up the case.

Start by gluing and clamping the subtop and the bottom divider between the sides (Fig. 2). These pieces (and all the other dividers), are sized to create a 1/2" setback from the front edge of the sides (Fig. 2a). They'll be "built out" later to fit flush with the face frame.

After squaring up the case, you can add the remaining dividers. Brush a thin coat of glue into the dadoes in the sides. Then slide in the dividers and clamp across the case.

Note: Be sure you don't accidentally rack the case out of square.

**FACE FRAME.** The next step is to add the face frame. It's made up of two long stiles (K), a narrow top rail (L), and a wider bottom rail (M) (Case Construction View).

The front stiles (K) are similar to those on the sides. But there's no groove on the inside edge. As for the outside edge, it's rabbeted to fit over the side stile (Rabbit Detail).

Once again, a short taper on the bottom of the stile forms a "foot." It's identical to the taper on the back stile of the side panels. (Refer to the Leg Taper Detail on page 3.)

**ATTACH STILES.** Now it's time to attach the stiles. They're simply glued to the

front of the case. Next, cut a top (L) and bottom rail (M) to fit between the stiles and glue them in place, too.

**CHAMFERS.** To complete the face frame, I routed two stopped chamfers (one long, and one short) on the outside edge of each stile. Besides adding a decorative touch, these chamfers help conceal the joint line where the front and side stiles meet (margin photo, page 4).

To accomplish that, mount a chamfer bit in a handheld router and set the depth of cut so the bit will just graze the joint line. After laying out the start and stop marks for each chamfer, set the base of the router on the stile and rout from left to right.

**EDGING.** With the face frame complete, the next step is to cover the exposed “plies” on the dividers with solid wood edging (N). The goal is to get the edging to fit flush with the front of the case (Edging Detail). For me, this meant ripping  $\frac{3}{4}$ ”-wide strips from  $\frac{3}{4}$ ”-thick stock, cutting the pieces to length to fit between the stiles, and then gluing them in place.

This is also a good time to rip a longer strip of edging (O) for the adjustable shelf and glue it on, too.

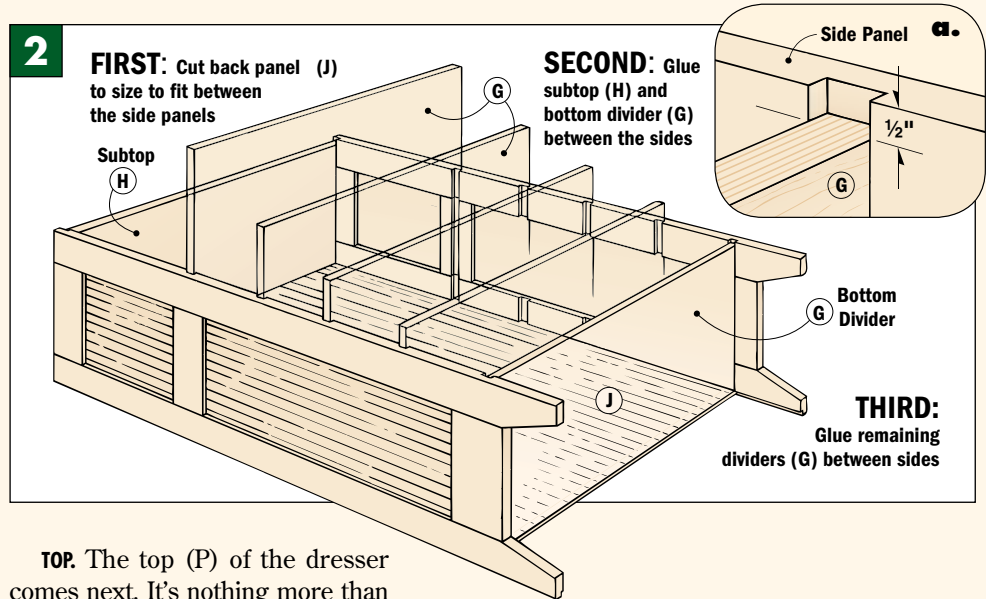

**TOP.** The top (P) of the dresser comes next. It’s nothing more than a  $\frac{3}{4}$ ” plywood panel. Notice that strips of molding with a bullnose profile (Q) are applied to front edge and sides of the dresser top. And strips of cove molding (R) underneath make for a decorative transition from the top to the case (Upper Molding Detail).

As for the bottom of the dresser, cove moldings with strips of quarter-round molding (S) below them help to create what appears to be a separate base for the dresser (Lower Molding Detail).

All of these moldings can be easily made in the shop with a router table,

a few router bits, and a table saw. (For more on this technique, turn to “Shop-Made Moldings” on page 10.) Once the moldings are made, they’re mitered to fit.

**ATTACH TOP.** It’s easiest to install the bullnose moldings before attaching the top. You’ll find a simple trick for aligning the mitered corners in the box below. Then, after centering the top from side to side and positioning it flush at the back, fasten it to the subtop with glue and screws.

With the top in place, attach the other moldings with glue and brads.

## TIGHTER MITERS — THE LONG & SHORT OF IT

When applying the decorative moldings to the dresser, I used a simple trick to ensure tight-fitting miter joints. The idea is to use a short mitered piece of molding as an alignment block for the adjoining piece (Step 1, below).



**1** A short alignment block that’s taped to the top of the dresser makes it easy to accurately position the side molding.

To position the block, cut an extra-long strip of side molding and fit the two pieces together. When the tips of the miters are nice and tight, attach the block with tape. Then apply glue to the side molding (but not on the mitered end), fit it against the



**2** After attaching the side molding, trim the long end flush with the back. Then repeat the process for the opposite side.

alignment block, and nail it in place.

After trimming the side molding flush (Step 2), use the alignment block again for the opposite side. Then miter the front molding to fit and attach it with glue and nails (Step 3).



**3** With the front molding mitered to fit between the sides, apply glue to both ends (and the back) and nail it in place.

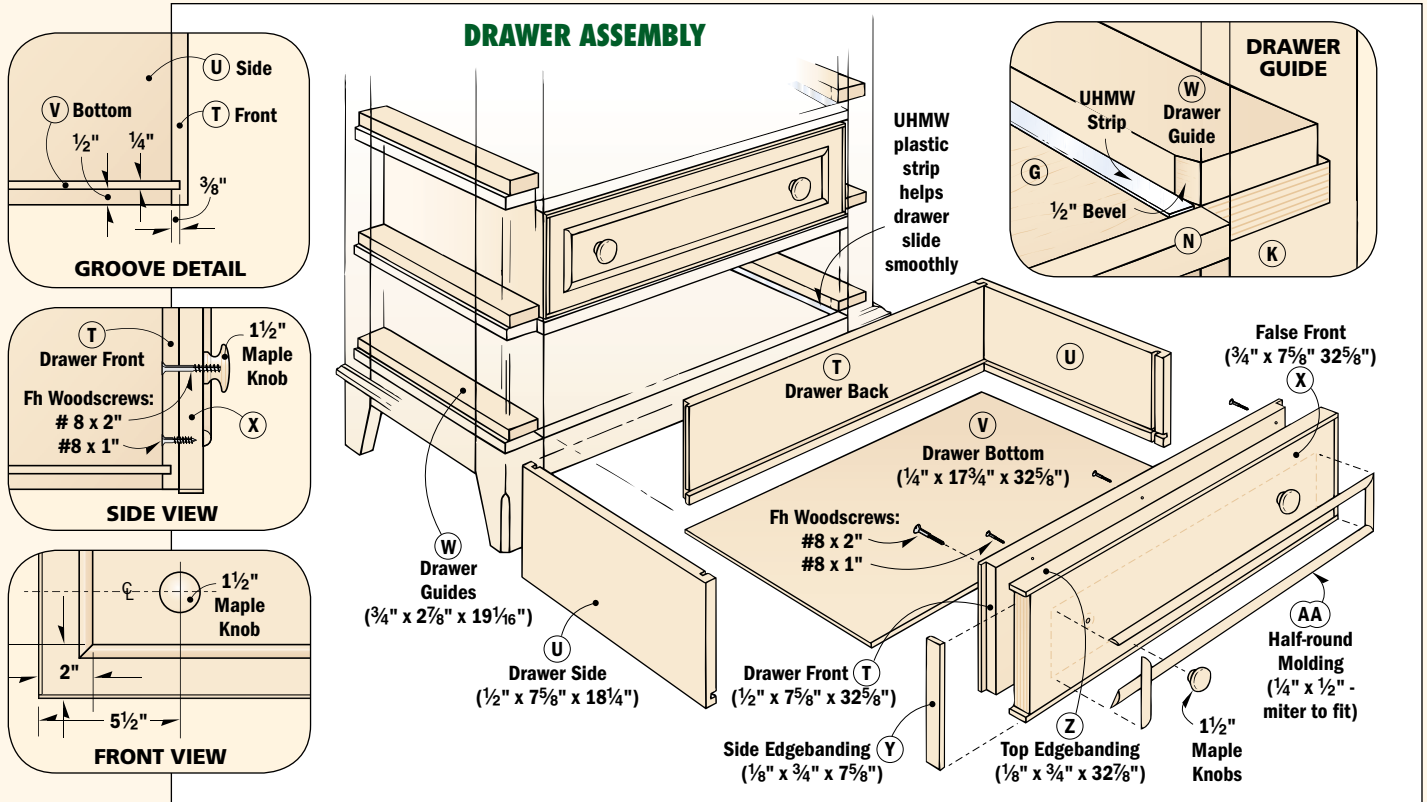

## Add the Drawers

The four drawers of this dresser start out as basic boxes that are assembled with tongue and dado joints. Then banded false fronts with decorative moldings are attached to the front of each of the drawer boxes. One thing that simplifies the construction is that all four drawers are identical in size,

so you can cut all of the parts using the same table saw setups.

**SIZING THE PARTS.** For clearance, the drawer box is  $\frac{1}{4}$ " shorter in height than the drawer opening. I also allowed for an  $\frac{1}{8}$ " gap on each side of the drawer box. With that in mind, rip the fronts, backs (T), and sides (U) to

width from  $\frac{1}{2}$ "-thick hardwood. Next, crosscut them to length.

**THE JOINERY.** Now it's time to cut the tongue and dado joints that are used to assemble the drawer boxes. In the box below, you can see how to do this with two simple setups on the table saw.

## TONGUE & DADO: A STRONG DRAWER JOINT



A tongue and dado joint is a good choice when building drawers. The tongue on the drawer front (and back) fits into a dado in the side, so it provides good mechanical strength, as well as a large glue surface.

The key to a tight-fitting joint is

to cut a test dado in a scrap piece and use it to check the fit of the tongue. The dado is only  $\frac{1}{8}$ " wide (a saw kerf). So a single pass on the table saw is all that's needed.

**TONGUES.** Each tongue is formed by cutting a rabbet (Figs. 1 and 1a).

To do this, mount a dado blade in the table saw and "bury" part of it in an auxiliary fence. Then make a trial cut in a test piece that matches the thickness of the drawers ( $\frac{1}{2}$ "). The tongue should fit snug (not tight) in the test dado. Once you're satisfied with the fit, rabbet both ends of the front and back to form the tongues.

**DADOES.** Now you can cut the dados in the sides. For this, just switch to the same blade you used to cut the test dado. Of course, you will have to adjust the blade height and fence position (Figs. 2 and 2a). Once again, make trial cuts to test fit the joint, and then cut the dados in the sides.

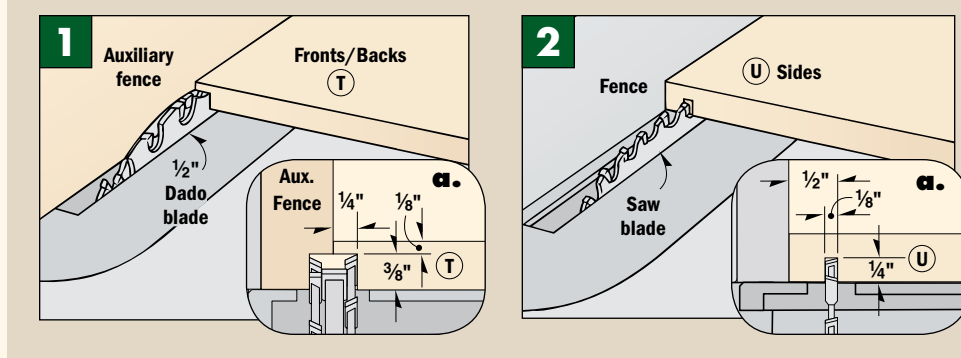



## MOLDING ALIGNMENT JIG

Four strips of half-round molding add a decorative touch to the dresser drawers. The challenge is positioning the strips on each false front so they align from one drawer to the next.

To accomplish that, I centered a hardboard alignment jig on each false front. This allowed me to wrap the molding strips around the jig so that they ended up the same distance from the edges of the false front on each drawer.

The jig is attached to the false front with screws (see drawing

at right). I know, that means you'll have to drill holes in the false front. But that's not a big deal really. The key is to locate these holes (see Front View) so that they can also be used to attach the knobs to the drawers.

To avoid accidentally gluing the jig to the false front, it's a good idea to wax the edges first. Then, after screwing the jig in place, glue the moldings around it. Fit the mitered corners as you work your way around. Tape is all you'll need to hold the moldings in place.

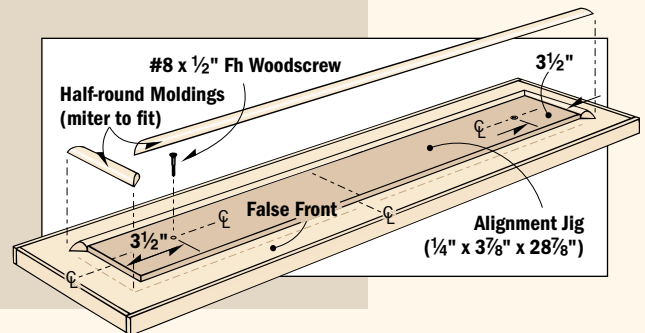

**CUT GROOVES.** There's one more thing to do before assembling the drawers. That's to cut a groove in each drawer piece to accept a plywood bottom (Groove Detail).

Once you've cut the grooves, go ahead and dry assemble the drawers to measure for the size of the drawer bottom (V). Then glue up and clamp the drawers.

**ADD GUIDES.** While the glue dries, you can get to work on the drawer guides (W). These are pieces of  $\frac{3}{4}$ " plywood that keep the drawers aligned as they open and close. A bevel on the inside corner of each guide makes it easy to install the drawer (Drawer Guide drawing on page 6).

After gluing the guides in place, I added two strips of Ultra-High Molecular Weight plastic. This is a slick plastic that helps the drawers slide smoothly and reduces wear (see margin photo at right).

**FALSE FRONTS.** The next step is to attach the false fronts (X) to the drawer boxes. These are  $\frac{3}{4}$ "-thick plywood pieces surrounded with  $\frac{1}{8}$ "-thick strips of solid wood edge-banding (Y and Z). Once the banding is added, the overall size of the false front allows for a  $\frac{1}{16}$ " gap all around the drawer opening.

**HALF-ROUND MOLDINGS.** To highlight the front of the dresser, I added four strips of half-round molding (AA) to the front

of each false drawer front. I made mine from  $\frac{1}{2}$ "-thick solid birch and mitered the corners (see page 10).

The real trick is positioning the moldings on each false front so that they line up from drawer to drawer. To accomplish this, I attached an alignment jig to the false front and then wrapped the molding strips around it (see the box above).

The final step before attaching the false fronts to the drawer boxes is to paint them. This is the only part of the drawer (except for the knobs) that gets painted. I used a clear finish on the drawer boxes themselves.

**ATTACH FALSE FRONTS.** The false fronts are attached to the drawer fronts with six 1"-long woodscrews (counter-sunk) from inside the drawer boxes.

You'll want the false front in position while you drill the holes for the screws. To ensure a consistent gap

around all four edges of the false front, I taped pennies to the case, as shown in Figures 3 and 3a.

Then I attached two strips of double-sided tape to the front of the drawer box and tipped the false front into place (see Fig. 3).

Now, carefully push out the drawer box from the back of the dresser. After removing the pennies, reposition the false front and secure it with screws.

**ADD THE KNOBS.** The drawers are nearly complete except for a pair of knobs for each drawer. These  $1\frac{1}{2}$ " maple knobs are painted and also attached with woodscrews through both the drawer front and the false front (see Side View, page 6).

Driving the screws through both fronts lets you access the screws easily if they should ever loosen up, or if you want to replace the knobs.



▲ Self-adhesive UHMW plastic tape makes for a smooth-sliding drawer with less wear. Order from Rockler at 800-279-4441.

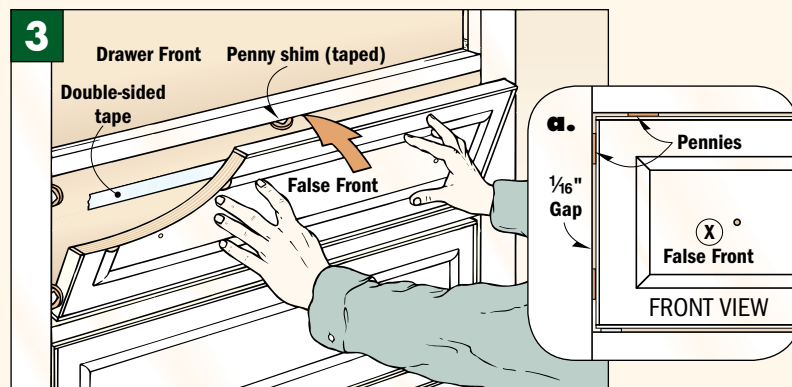

## DOOR ASSEMBLY AND INSTALLATION

**NOTE:** Doors are assembled with stub tenon and groove joinery like the side panels

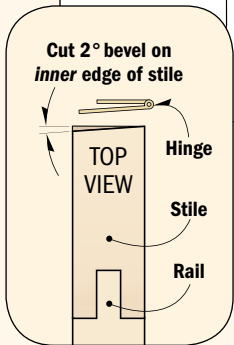
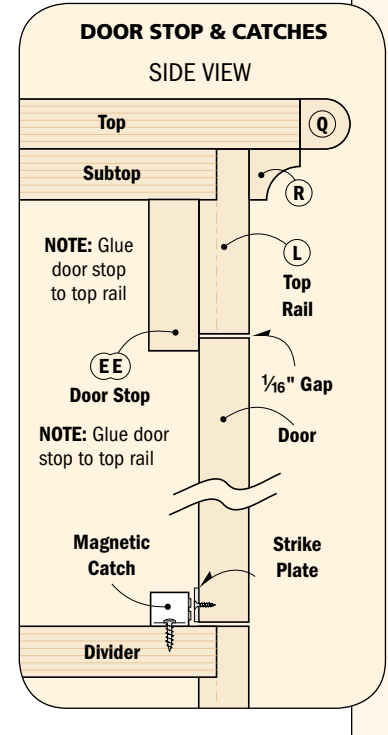
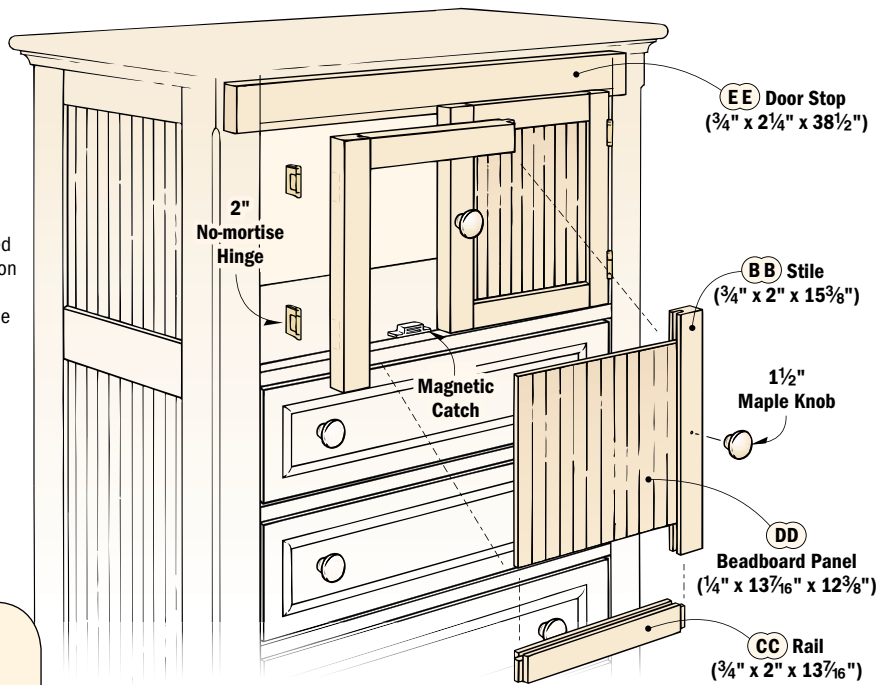

▲ To keep the door from binding, rip a slight bevel (2°) on the hinged edge of the stile.

### Add a Pair of Doors

The shelving compartment at the top of this dresser provides ample storage for sweaters, books, or other small items. To enclose this compartment, I added a pair of inset doors.

Like the sides, the doors consist of a solid-wood frame surrounding a beadboard panel. Here again, stub tenon and groove joinery makes for a strong, easy-to-build door.

**STILES, RAILS & PANELS.** The doors are

sized to leave a 1/16" gap all the way around. With that in mind, and after taking the joinery into account, cut the stiles (BB) and rails (CC) to size.

To accept the beadboard panel (DD), you'll need to cut a groove in the inside edge of the stiles and rails. Then cut stub tenons in the rails to fit the grooves. Note: Size the grooves and tenons to match those on the side panels (see page 3).

**ASSEMBLY.** The next step is to glue

and clamp the door. Be sure to run a bead of glue all the way around the grooves to glue in the beadboard panel. This will help give the door frame added strength. You can also add the door knobs now. They're centered on the inner stiles.

**FITTING THE DOORS.** With the doors assembled, it's time to hang them in the opening. I used no-mortise hinges to attach them. But they still need to fit flush in the opening with a consistent gap all around the edges. A look at the box at left shows an easy way to accomplish this.

As added insurance against binding, I used the table saw to rip a 2° bevel on the hinged side of the door (see drawing in left margin).

**STOP AND CATCHES.** After attaching the hinges, you'll need something to stop the doors as they swing shut — a door stop (EE) and a pair of magnetic catches.

The stop is just a piece of 3/4"-thick hardwood that extends below the top rail far enough for the doors to hit it (Door Stop & Catches drawing). It's cut to length to fit between the side panels and then glued in place. Finally, to complete the dresser, add the magnetic catches.

## HINGE INSTALLATION TIP

Installing a door with no-mortise hinges is a quick job. That's because there's no need to, well, cut a mortise for the hinge. Instead, it's surface-mounted.

But without a mortise, how do you hold the hinge in place and keep the door properly aligned? The key is to "fix" the door in its open position.

To do that, clamp it against shims that match the thickness of the hinge barrel, see drawings. Check that the inside edge of the door aligns with the dresser stile.

Also, be sure you'll end up with an even gap on top and bottom. Now fit the barrel of the hinge in the opening made by the shims. Then screw the hinge in place.

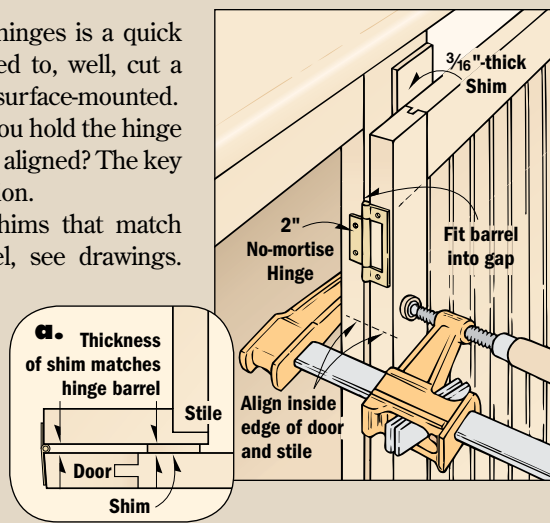

## Creating an “Antique” Finish

To bring out this dresser’s cottage charm, I wanted to make it look old. But I didn’t want to wait for it to age on its own. So to speed things up, I used a painted finish that’s “distressed” to make it look antique.

There’s more to this finish than a coat of paint, however. The process involves applying three different finish products: stain, paint, and a topcoat.

**START WITH STAIN.** Okay, so why go to the trouble of staining a dresser that’s going to be painted? Because in order to create an old-fashioned look, the idea is to sand through the paint to the stain underneath it.

To create a contrast with the white paint, I chose a dark-colored, oil-based stain (*Minwax Colonial Maple*). You don’t have to be too particular about getting a nice, even stain. Remember, it’s going to be covered with paint. So just brush on the stain (Step 1) and then wipe off the excess.

**WAIT, THEN PAINT.** After applying the stain, don’t get in a hurry to paint

the dresser. The stain has to dry thoroughly — at least two days — before you paint it. Otherwise, the solvents in the stain could prevent the paint from bonding properly.

As for choosing a color, white is very popular for cottage-style furniture. I brushed on two coats of a satin, latex paint (*American Accents Blossom White*), as shown in Step 2.

**DISTRESS FOR DISTINCTION.** The next step is to “distress” the dresser by sanding through the paint to the stain (Step 3). The idea is to hit the areas that get the most wear. I also sanded the beads on the doors and side panels, see photos at right.

Just a note of caution here. A light touch is all that’s needed. You don’t want to remove too much paint, or accidentally sand through the stain to bare wood.

**TOPCOAT.** The final step is to apply a topcoat that “evens out” the dull spots caused by sanding (Step 4). I used a water-based polyurethane to prevent the paint from yellowing.



▲ Add 100 years to this dresser in a few hours. The secret is to “knock off” the paint on the beads and in areas of wear.



**1** To begin the “aging” process, start by applying a dark-colored stain with a foam brush. Don’t worry about getting a nice, even stain. Just brush it on, then wipe off the excess with a rag.



**2** Then brush on two coats of a satin, latex paint. When each coat dries, remove any “nibs” with 400-grit wet/dry sandpaper. To avoid clogging the sandpaper, I used water as a lubricant.



**3** Use an abrasive pad to sand through areas that are likely to get the most wear — edges, corners, and around knobs. I also sanded the beads on the door and side panels (photos above).



**4** In addition to the extra protection it provides, the topcoat “evens out” the dull spots caused by sanding. I used a water-based polyurethane finish to prevent the paint from yellowing.

# SHOP-MADE MOLDINGS



All you need to make your own moldings is a router table, some common router bits, and a table saw.

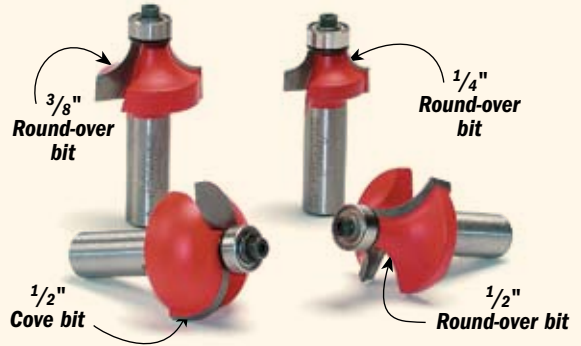

## SHOP TIP

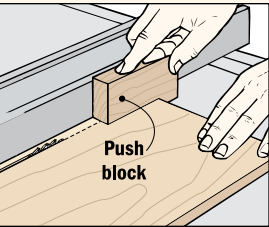

▲ Use a 2x4 block with a "heel" to push the board through the saw blade.

## NOTE

Use a fence with your Router Table. (Fence removed for clarity).

## BULLNOSE MOLDING

### ROUTING

3/4"-thick Stock  
3/8" Round-over bit

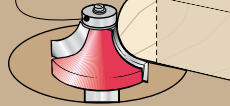

### RIPPING

Push block  
3/4"

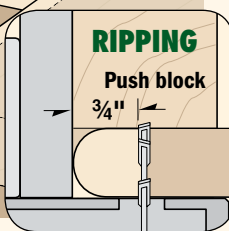

## QUARTER-ROUND MOLDING

### ROUTING

1/2"-thick Stock  
1/2" Round-over bit



### RIPPING

Push block  
1/2"

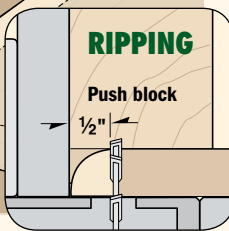

## COVE MOLDING

### ROUTING

3/4"-thick Stock  
1/2" Cove bit



Remove waste in two passes

### RIPPING

Push block  
3/4"

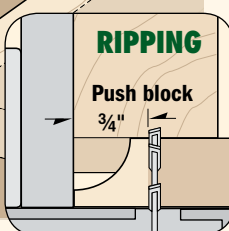

## HALF-ROUND MOLDING

### ROUTING

1/2"-thick Stock  
1/4" Round-over bit

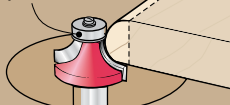

### RIPPING

Push block  
1/4"

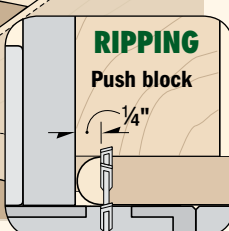

## Shop-Made Moldings

Adding decorative moldings to a project such as the Cottage-style Dresser is a great way to dress up furniture. You can see the four profiles used in the drawings at left. The problem is sometimes it's hard to find moldings with the profile you're after. And when you're using a natural finish on your projects, finding stock moldings to match the type of wood you're using can be difficult.

When this happens, an easy solution is to make your own moldings. To do this, all you need is a router table, some common router bits (see photos above), and a table saw.

To make the moldings for the Cottage-style Dresser, I used a two-step process (see drawings at left). The first step is to rout a profile on the edge of a wide board on the router table. Then the profiled edge is ripped off the board on the table saw.

**STEP 1: ROUTING.** When routing the profile, the workpiece is guided by a bearing on top of the bit. Even so, it's a good idea to use a fence, which provides extra support. As always, use a wide board and keep your hands well away from the spinning bit as you push it past the bit. For safety, always make it a point to rout profiles on boards that are at least 2" wide.

Routing most of these moldings can be done in a single pass. However, when making the cove molding, you'll need to remove quite a bit of material. So it's best to rout the profile in two or more passes. Start with a shallow cut, then raise the bit to finish the cove profile (see Cove Molding drawing).

**STEP 2: RIPPING.** To ensure your finished moldings are consistent when ripping the profiled edge, position the workpiece with the profiled edge to the inside of the blade against the fence.

Then use a heeled push block (2x4 works well) to guide the workpiece through the cut and on past the blade (see the Shop Tip in the left margin).