



Woodsmith **PLANS**

CRAFTSMAN-STYLE WALL MIRROR



CRAFTSMAN-STYLE WALL MIRROR

A stylish design with plenty of woodworking details makes this mirror a hit in the shop and the home.

A wall mirror is a welcome addition to just about any room. It helps add depth in a small space, like a hallway, or it can provide a nice accent in a larger setting. The design for this mirror makes it not only attractive, but easy to build, as well.

As you can see in the photo, the basic mirror frame is pretty straightforward. But a handful of details makes the mirror a more interesting piece. For example, a narrow shelf supported by corbels offers a place to display small items. And the decorative cove moldings between the corbels and on the top really give the mirror a more refined look. All in all, it's a great weekend project.



MATERIALS & SUPPLIES

A Stiles (2)	$\frac{3}{4}$ x $2\frac{1}{2}$ - 34 $\frac{1}{2}$
B Top Rail (1)	$\frac{3}{4}$ x $2\frac{1}{2}$ - 13 $\frac{1}{2}$
C Bottom Rail (1)	$\frac{3}{4}$ x $7\frac{1}{2}$ - 13 $\frac{1}{2}$
D Cap (1)	$\frac{3}{4}$ x 2 - 20
E Upper Cove Molding (1)	$\frac{3}{4}$ x $\frac{3}{4}$ - 24 rgh.
F Shelf (1)	$\frac{3}{4}$ x 3 - 16
G Corbels (3)	$\frac{3}{4}$ x $1\frac{3}{4}$ - 2 $\frac{1}{4}$
H Lower Cove Molding (1)	$\frac{3}{4}$ x 2 - 18 rgh.
I Interior Frame Stiles (2)	$\frac{1}{4}$ x $\frac{1}{4}$ - 24
J Interior Frame Rails (3)	$\frac{1}{4}$ x $\frac{1}{4}$ - 12
K Interior Frame Muntins (3)	$\frac{1}{4}$ x $\frac{1}{4}$ - 4
L Back Panel (1)	$\frac{1}{4}$ hdbd. - 12 x 24

- (2) #8 x $1\frac{1}{4}$ " Fh Woodscrews
- (6) Brass Turn Buttons w/Screws
- (1) 11 $\frac{7}{8}$ " x 23 $\frac{7}{8}$ " Mirror
- (1) 6" Frame Hanger
- (2) $\frac{1}{2}$ "-dia. Bumpers

CUTTING DIAGRAM

$\frac{3}{4}$ " x $7\frac{1}{2}$ " - 96" Oak (5 Bd. Ft.)

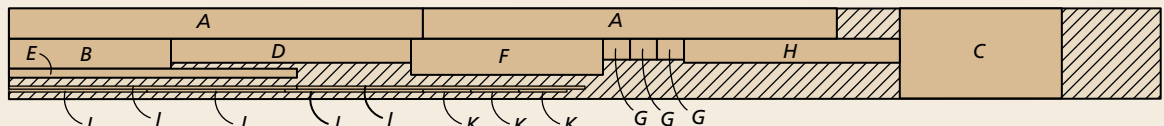

Starting the Frame

The decorative frame needs to provide a solid foundation to carry the weight of the mirror and the shelf. So I chose mortise and tenon joinery to make sure it was up to the task. Because the bottom rail is extra wide, I used a double tenon to join this piece to the stiles.

STILES. Since I like to cut the mortises first and then match the tenons to them for a snug fit, I started with the stiles. After cutting the stiles to final size, you can lay out the mortise locations and drill out most of the waste at the drill press with a Forstner bit. Then clean up the sides and corners with a sharp chisel.

RAILS. Next, you'll cut the rails to size and get to work on the tenons. As you can see in the drawing at right, the top rail is straight with a single tenon on each end. The bottom rail, however, not only features double tenons, but a gentle curve on the lower edge as well. I cut the tenons first, while the workpiece was still square. The box at the bottom of the page shows an easy way to turn one wide tenon into the double tenon you'll need here.

Once you've finished cutting and fitting the tenons, you can turn

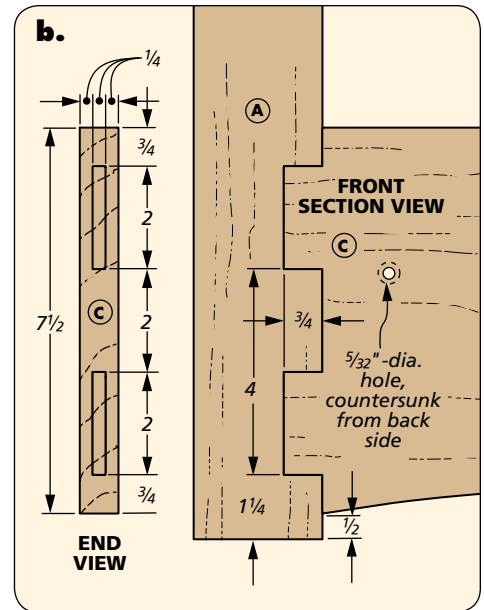
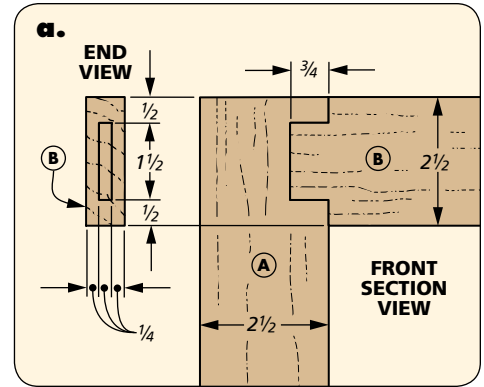
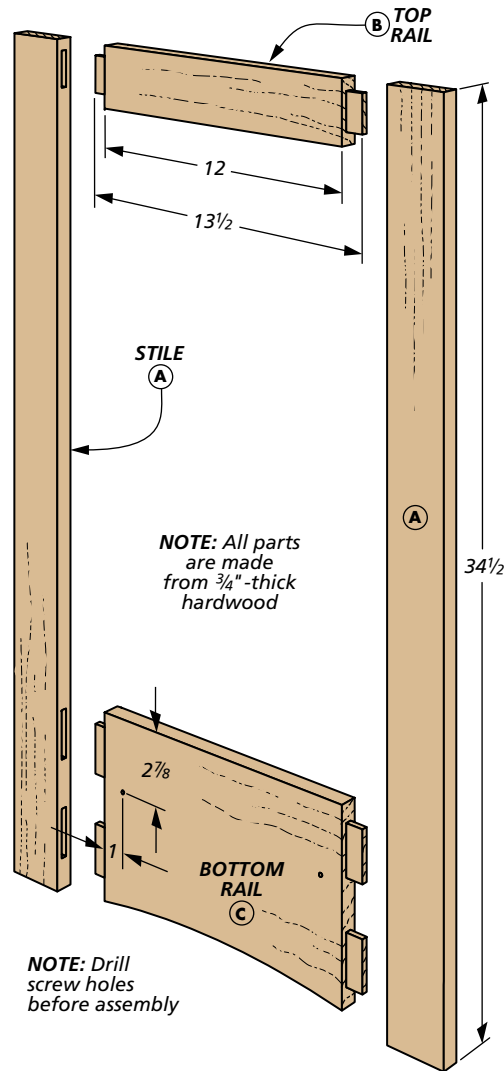

your attention to the curve on the bottom rail. For this, I laid out the curve using a string and a piece of hardboard. The right drawing in the box shows how to do it. After cutting

the curve on the band saw, clean up the edge with a sanding drum. Then you can drill the countersunk screw holes for the shelf and assemble the frame with glue.

HOW-TO: CONSTRUCTION DETAILS

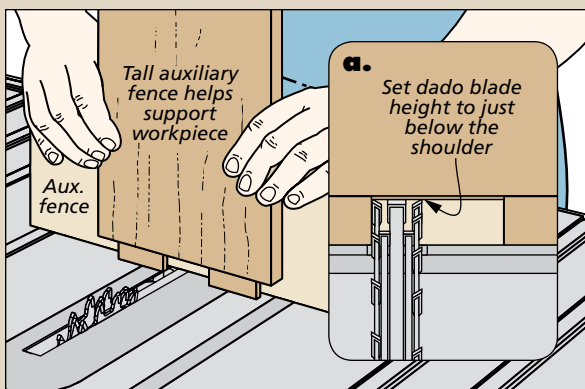

Double Tenon. After cutting the cheeks and shoulders, use the miter gauge and an auxiliary fence to nibble away the waste to form the double tenon.

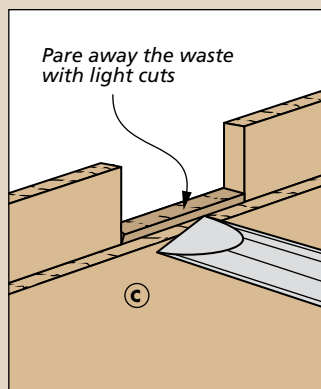

Cleaning Up. A sharp chisel is all it takes to clean up the space between the tenons.

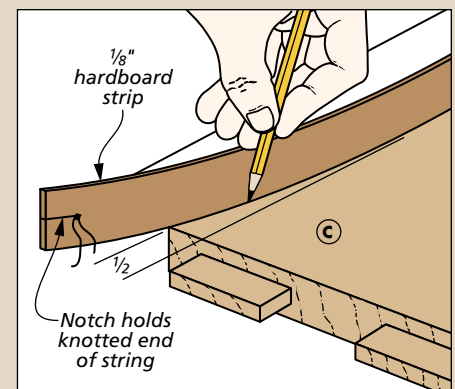

Layout. Use string to bend a narrow strip of hardboard to the desired curve, and then trace the edge with a pencil.

Adding the Details

As I mentioned earlier, it's the decorative details that really make this mirror stand out. After the glue dries on the assembled frame, you can get started on those details.

START WITH THE CAP. The first thing to add is the hardwood cap that sits atop the frame you just created. All you need to do here is cut it to final size and attach it with glue.

COVE MOLDING. The next step is to make the cove molding that fits under the cap. This molding provides a smooth transition from the frame to the cap. To make the molding, I started with a wide blank and routed the profile on the edge, as shown in detail 'b.' Then I moved to the table saw and ripped the piece of molding to final width.

When you've completed the molding, you can go ahead and miter the pieces to final length. The main drawing and detail 'a' show how the molding fits, including the small returns on each end. Shop Notebook, on page 6, has a few tips for this.

SHELF. At this point, you can move on to adding the shelf. Once again, it's simply a matter of cutting the shelf to final size and attaching it to the bottom rail. In addition to glue, I used screws to ensure a strong joint, as you can see in detail 'd.'

CORBELS & MOLDING. The small corbels and cove molding under the shelf add another decorative touch. To make the corbels, you simply need to cut the blocks to size and then cut out the rounded profile at the band saw. After a quick cleanup with a sanding drum, you can attach them with glue.

Now you can turn your attention to the lower cove molding. This molding is a little different than the simpler molding I used on the cap. For more information on making the molding on the table saw, turn to Shop Notebook on page 5. After completing the cove molding, cut the two center pieces to fit between

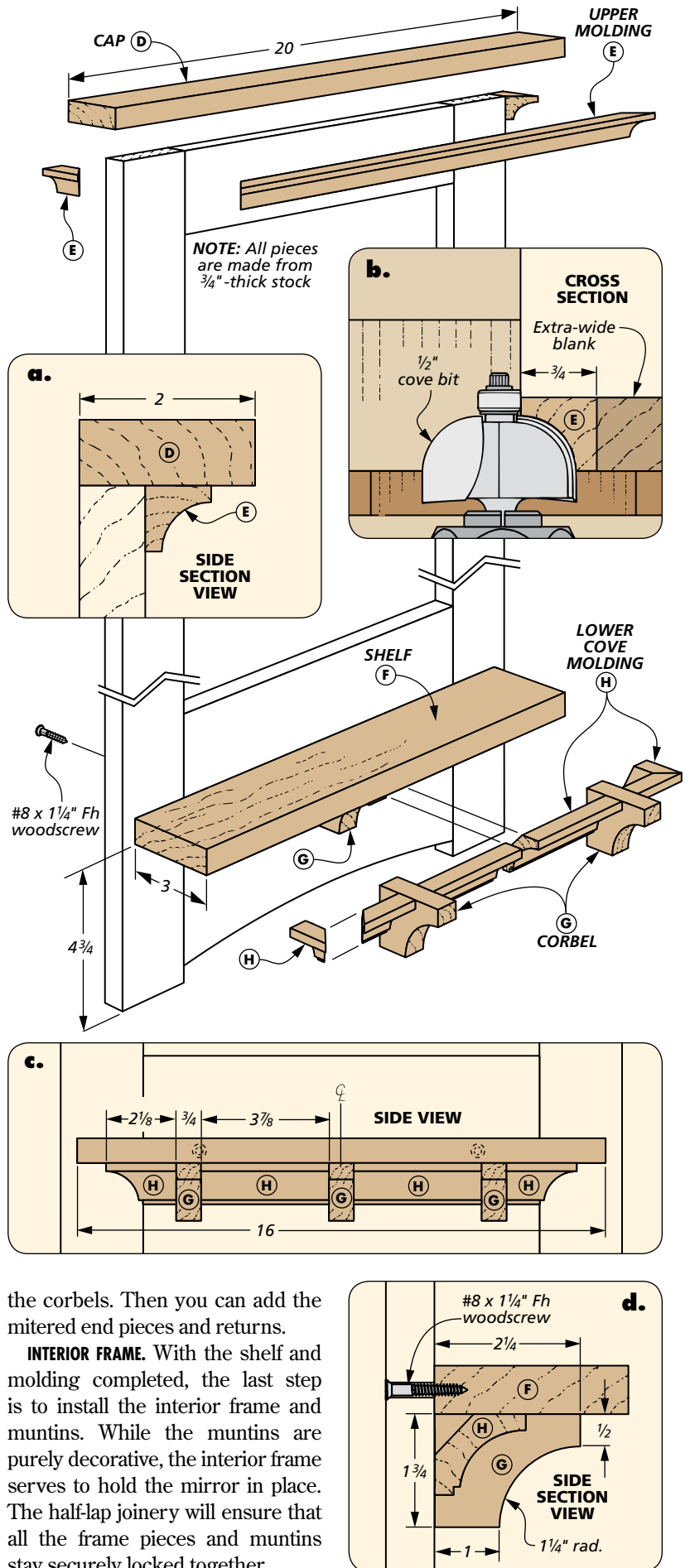

▲ To learn how to make molding on the table saw, turn to page 5.

the corbels. Then you can add the mitered end pieces and returns.

INTERIOR FRAME. With the shelf and molding completed, the last step is to install the interior frame and muntins. While the muntins are purely decorative, the interior frame serves to hold the mirror in place. The half-lap joinery will ensure that all the frame pieces and muntins stay securely locked together.

The first step in making the interior frame is to rip your stock into 1/4" x 1/4" strips. In addition to using a push block, I also installed a zero-clearance insert on my table saw to safely make the narrow rip cuts. While you're at it, it's a good idea to cut an extra piece to use for setting up the saw for the half-lap cuts.

Now you can cut the rails and stiles to length. For this, I took the time to fit each piece carefully. You can make sure of a good fit by starting a little long and then sneaking up on the final length — dry fitting each piece in the frame as you go.

Once you have all the pieces cut to length, install a dado blade in the table saw and cut the half laps. The box below shows you how to get a good fit here, as well. When you're done, dry assemble the pieces to make sure they all fit together well. Now you can glue the pieces in place, starting with the rails and stiles. Then add the muntins.

MIRROR & HARDWARE. There are a few things left to complete the mirror. First, I applied a coat of *Varathane Early American* stain followed by two coats of lacquer. After finishing your project, cut the hardboard back to final size and fit the mirror in place. Secure the back using turn buttons and screws. Finally, attach the hanger and bumpers on the back.

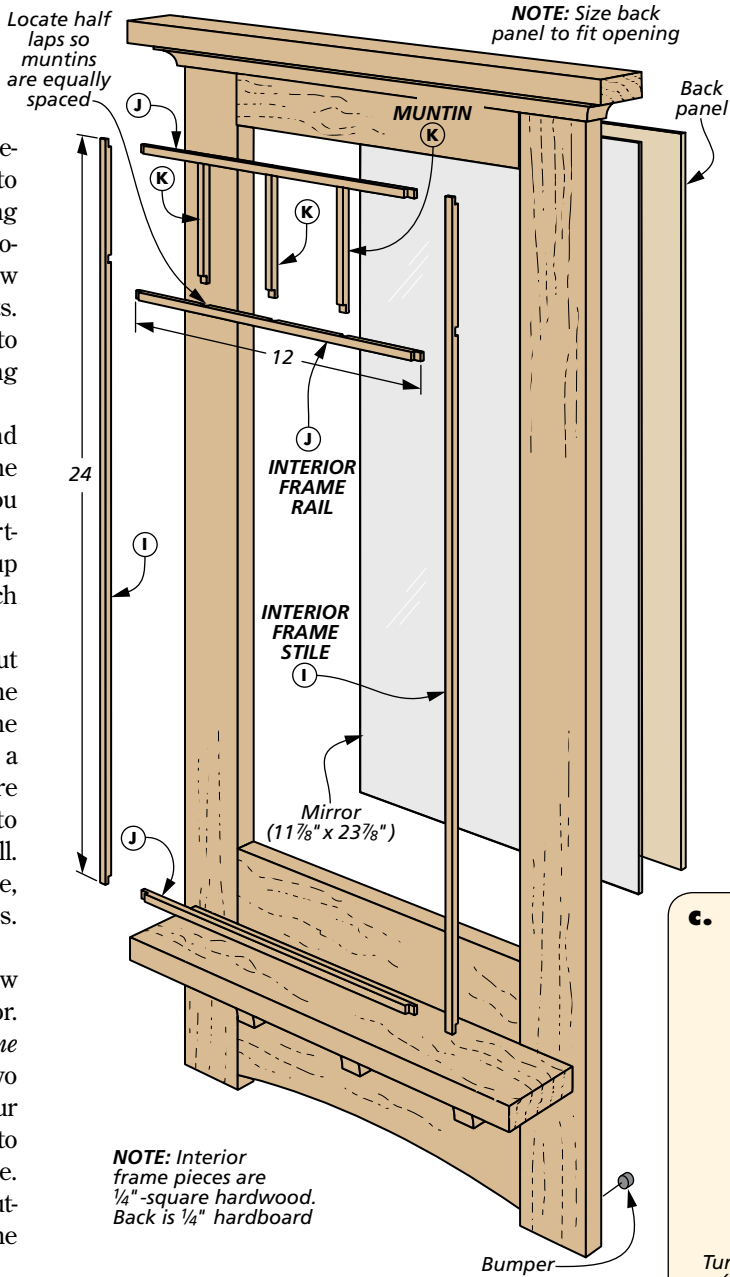

NOTE: Interior frame pieces are 1/4"-square hardwood. Back is 1/4" hardboard

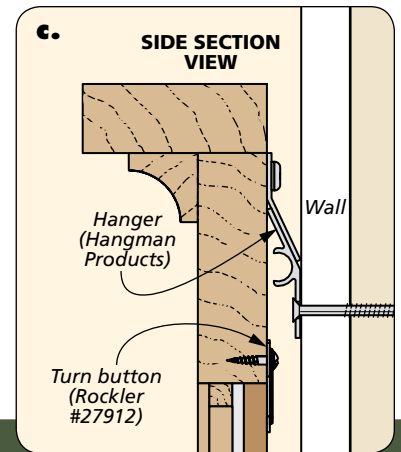
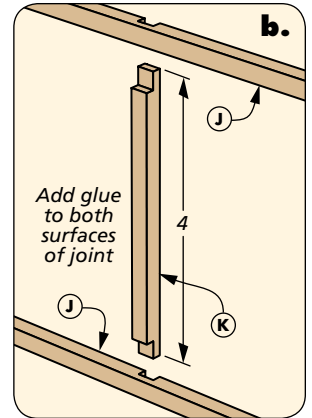
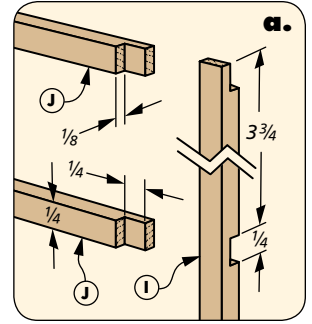

HOW-TO: MAKE & INSTALL THE INTERIOR FRAME

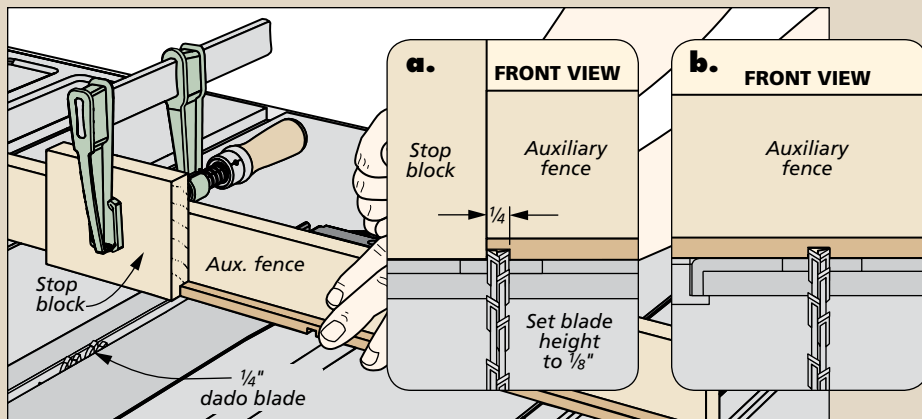

Half Laps. With an auxiliary fence and a dado blade installed, use a test piece to sneak up on the proper blade height (half the thickness of the workpiece). Add a stop block to make sure the half-lap cuts are in the correct positions.

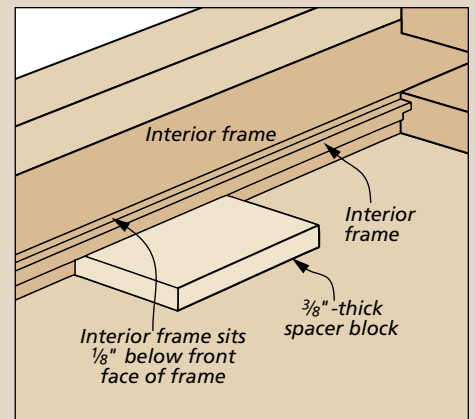

Attach the Frame. After dry fitting the interior frame, use spacer blocks to position the pieces. Then add glue and clamps.

SHOP NOTEBOOK

Cove Molding

Although you might think the cove molding used on the Craftsman-style wall mirror was made on a router table or shaper, it's actually made entirely on the table saw.

You start by cutting a shallow cove on one face of a blank. To do this, lay out the cove on the end of a blank (detail 'a' at right). Then clamp a pair of fences to the top of your table saw at a 30° angle to the blade, as shown in the main drawing at right.

Cut the cove by making multiple passes over the blade, raising the blade no more than 1/16" after each pass. Keep in mind that it's important to use push pads or push blocks when cutting the cove.

After cutting the cove and sanding away any saw marks, make a series of beveled rip cuts along all four edges of the blank. This will allow the molding to fit against the shelf and mirror frame at an angle.

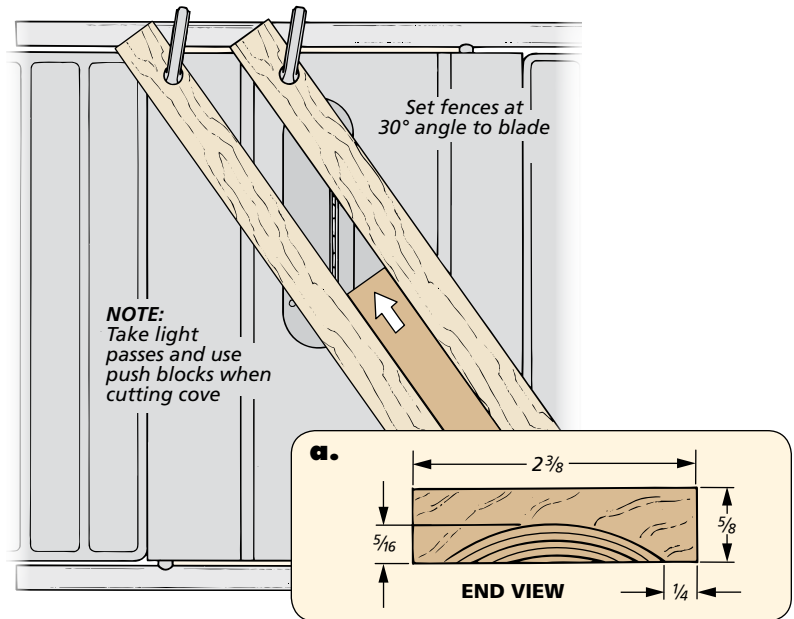

All the cuts are made with the blade tilted 45°. You can see the sequence of cuts in Figures 1 and 1a.

The last step to complete the cove molding is to cut the small rabbet,

or fillet, along the bottom edge. I did this in two steps. First, cut a wide rabbet, as shown in Figure 2. Then, turn the workpiece over and position the fence to trim the edge (Figure 3).

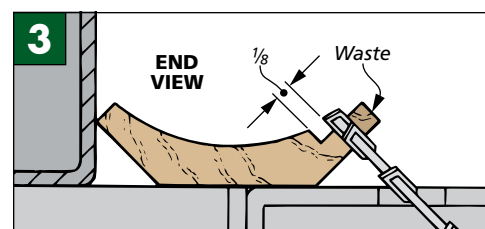
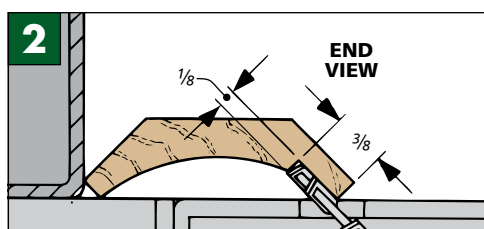
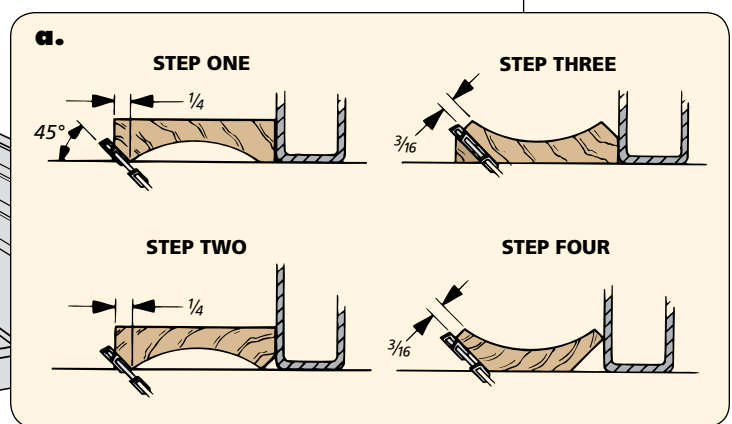
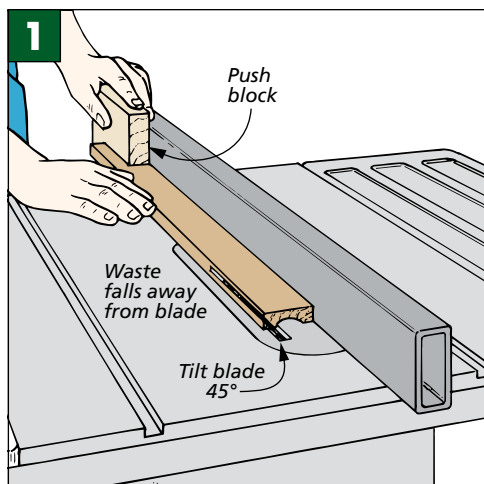

Cutting Mitered Returns

The mirror calls for mitered moldings with short returns on the ends. Trying to cut these pieces on a miter saw or table saw can be a challenge. When you cut the return off the end of a longer piece, it usually “zings” across the shop, often getting lost.

To make the task a little easier, here’s a simple trick. Start by mitering the end of the molding or blank. Now, instead of cutting the return

from the end of the blank, lower your saw blade so it’s about $\frac{1}{32}$ " below the height of the molding, as shown in Figure 1.

This way, when you cut the return to length, rather than flying away, it remains attached to the rest of the molding by a thin “bridge.” A utility knife can then be used to cut the return free from the rest of the molding, as illustrated in Figure 2.

