



THANK YOU!

You have successfully downloaded your *Woodsmith* project plan.

▶ [Go to Page 1](#)

Get More from Your Band Saw...at PlansNOW.com



Build this Elegant Hall Table Using Your Band Saw

We'll show you how to cut and shape table legs on a band saw—a technique you can use on any woodworking project.

▶ [Download Today at PlansNOW.com...\\$9.95](#)



Build a Table and Fence for Your Band Saw

The table creates a large work surface that's about three times the size of the cast iron table your band saw came with.

▶ [Download Today at PlansNOW.com...\\$5.95](#)

You Can Build It...at PlansNOW.com



Workbenches

Good woodworking starts with a solid workbench.



Shop Jigs & Techniques

Get the most from your tools with easy-to-build shop jigs.



Cabinets & Shelves

Build stunning furniture that's both functional and beautiful.



Home Improvement

Save hundreds of dollars in remodeling when you DIY.



Woodsmith **PLANS**

CURVED LEG END TABLE



CURVED-LEG END TABLE

Create the gracefully curved legs for this table using an easy, bent-lamination technique.

There are a couple of things about this table that catch your eye right away — the sweeping curve of the legs and the decorative, circular inlay in the round top. But if you take a closer look at these details, you'll discover that there's more here than meets the eye.

LAMINATED LEGS. For example, each of the legs looks like it's cut from a single piece of wood. But they're actually made up of thin layers, bent in a curve and glued together. The good news is, the laminating technique is pretty easy to master.

EPOXY INLAY. You might also assume that the decorative inlay is wood. In fact, it's colored epoxy. This creates a great effect without the hassle of fitting inlay pieces. It's just poured into a shallow, routed groove.

This project is a great opportunity to try both techniques. And the end result is an attractive table.



▲ The key to bent-lamination is a solid bending form. The double layers of MDF on this form provide plenty of strength and lots of places to add clamps. The form also detaches from the base so it can be used with a miter gauge to trim the ends of the legs to their finished length at the table saw.

Start with the Legs

Like most tables, this project can be divided into two parts — the base and the top. The base consists of four identical legs made using a bent-lamination technique. Since each leg needs to remain in a bending form for a full day, I began by making the legs first. This way, you can work on the top in between gluing up the legs.

MAKE A TEMPLATE. To get started on the base, the first step is to lay out the shape of the legs on a piece of $\frac{1}{4}$ " hardboard, like the one you see on the far right. This way, you'll have a full-sized pattern. And later you'll use it to lay out the shape of the bending forms. For now, just cut out the template and sand it smooth.

CUTTING THE LAMINATES. Now you're ready to cut the thin strips for the laminations. For a curve of this radius, the thickness of each strip should not exceed $\frac{1}{8}$ ". I did this by cutting some $\frac{3}{4}$ "-thick stock into $1\frac{1}{2}$ "-wide blanks and then resawing them into thin strips, as shown below. You'll want to stack and mark the pieces in the order they were

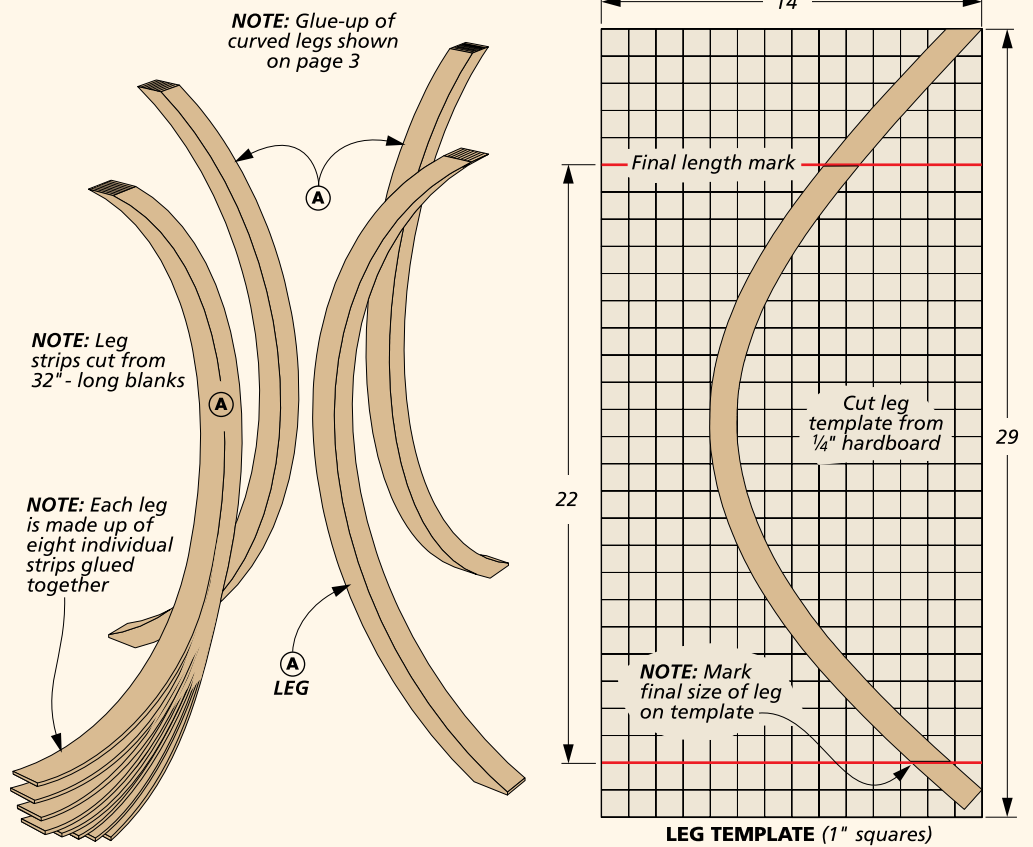

cut to keep them in place for the glue-up. Keeping them in order will help you get a seamless glue line when you assemble the pieces.

At this point, you can feel how the strips will bend. Don't be concerned if it seems like they won't bend far enough without cracking. They'll become more flexible as they absorb some moisture from the glue.

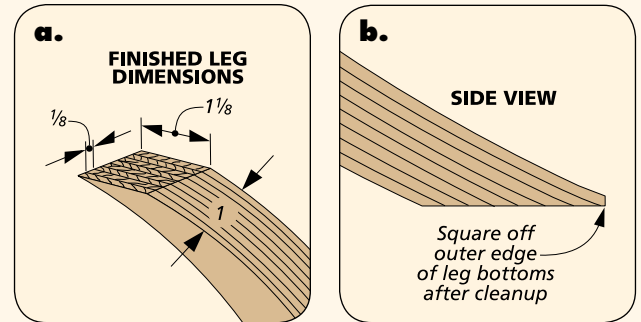

CUTTING THIN STRIPS

To cut the thin strips needed for the laminated legs, first install a good rip blade on your table saw. Then just set your fence a hair wider than $\frac{1}{8}$ " and rip the strips. Make sure to

use a push block with a small heel to safely hold the thin pieces.

Now you can remove the saw marks by using a sanding drum on your drill press and a support block

attached to the fence. With a 100-grit sleeve on the drum, all you need to do is pull each strip through the drum to leave a smooth, flat surface ready for glue-up.

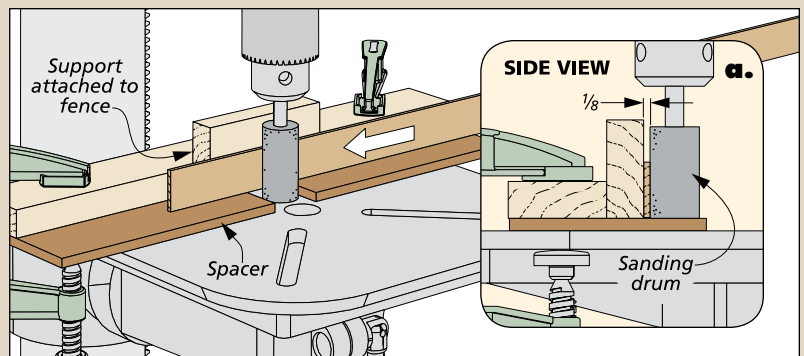
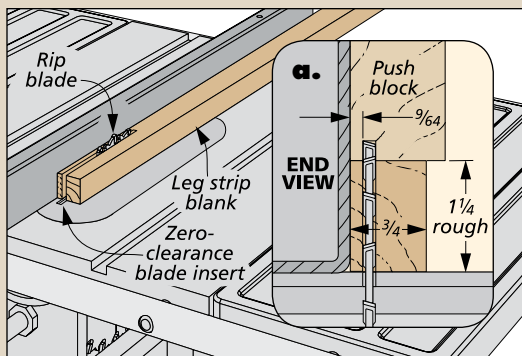

Gluing Up the Legs

With the strips for the legs cut and the template shaped and sanded, you're ready to build the bending forms. The box at the bottom of the page shows you how that's done.

After you've completed the form, it's a good idea to give it a coat of finish and thoroughly wax the surfaces that will come in contact with glue. This way, you'll have a much easier time removing the pieces.

GLUE THE LAMINATIONS. Once the form is built, you're ready to start gluing up the legs. One thing to keep in mind here is that you'll be covering



a lot of surface and it can be time-consuming. So it's important to use a glue that gives you plenty of open time before it sets up. I used *Titebond Extend*, a strong PVA glue that provides extra open time.

How you apply the glue is also important. You can roll or brush it on, but you'll need to make sure to fully cover every surface to prevent voids in the lamination (Fig. 1).

CLAMP THE FORMS. After you've completed the glue "sandwich," just tip

it on its side, as shown in Fig. 2, bend it around the form, and use a couple dowels to hold the lamination secure. Then move the outside form into position and add a single clamp (Fig. 3) in the center to hold things in place. Now you can add more clamps to the form, alternating between the right and left side of center, slowly bringing the pieces together. Use a piece of scrap and a mallet (detail 'a') to tap the strips flat against the bottom of the form.

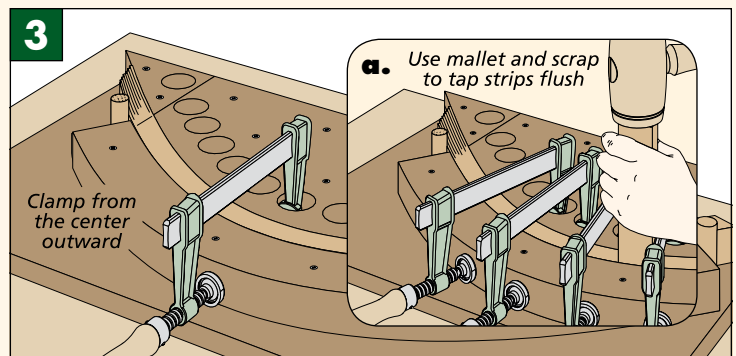
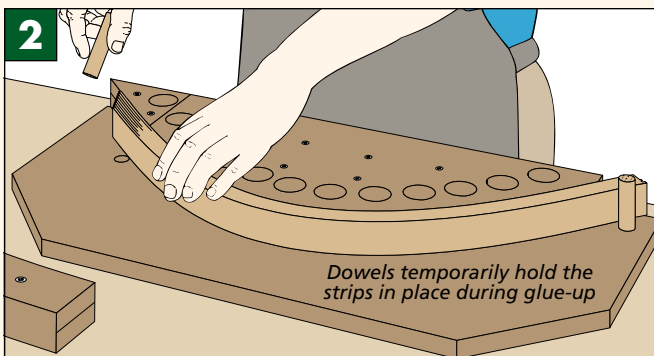
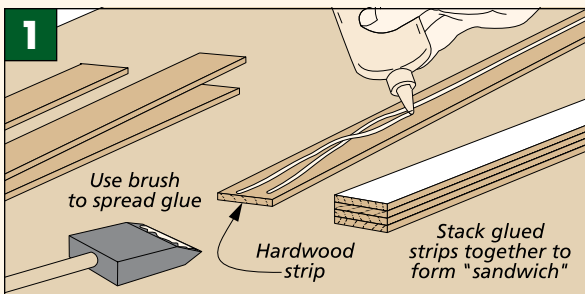

BUILD THE BENDING FORM

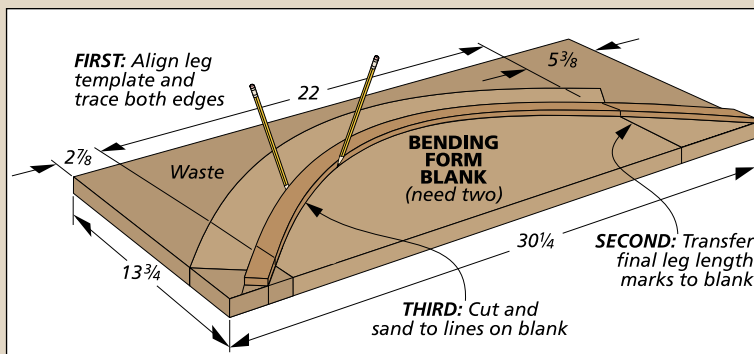

Start with the Template. Trace the shape of the template onto a piece of $\frac{3}{4}$ " MDF. Cut out both pieces of the form, staying on the waste side of the cut. Then sand the edges smooth.

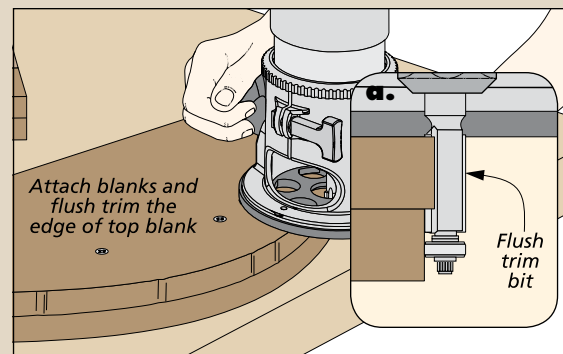

Add a Second Layer. Cut out a second piece of MDF and attach it to the first layer with glue and screws. Then, with a flush-trim bit in the router, trim the pieces to match.

CLEANING UP. You'll need to give the glue a full day to cure before removing the leg from the bending form. After gluing up the remaining three legs, you can break out a scraper and remove the squeeze-out. I also like to follow up with a good sanding to remove as much of the hardened glue as possible. Then just flatten one edge of each leg at the jointer and run the other side through your planer. Plane the leg to a final width of $1\frac{1}{8}$ ".

SQUARE THE ENDS. Now you're ready to trim the ends of the legs parallel. This way, they'll sit flat on the floor and also create a flat surface for the top of the table. The bending form comes in handy for making these cuts. Just remove the inside form and attach it to an auxiliary fence on your miter gauge, as shown in Fig. 6. Then you can clamp the leg in position on the form and make the squaring cuts on each end.

FLATTEN ONE FACE. With the legs cut to length, the next step is to create a flat spot on the inside face of each leg for a center block that will be added later. This will allow you to assemble the legs into a solid base.

To do this, remove the form from the miter gauge and place the flat edge against the rip fence (Fig. 7). Hold the leg in position with spring clamps, well out of the way of the table saw blade. For this cut, I carefully adjusted the rip fence to just

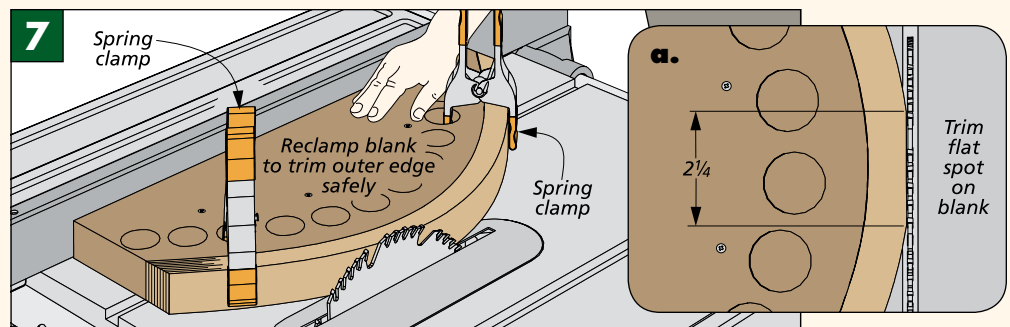
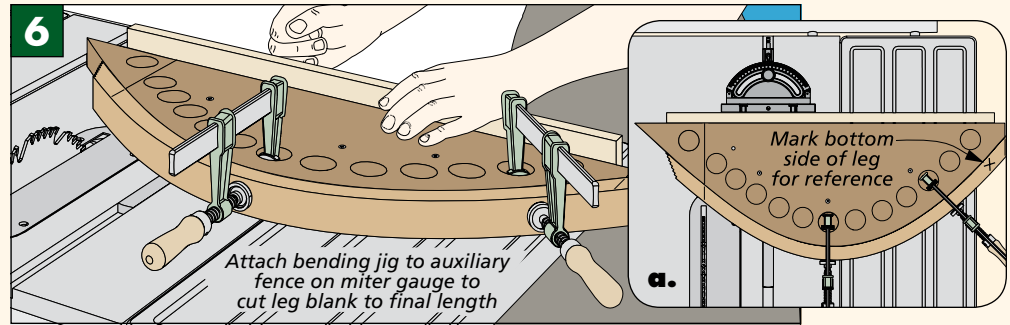
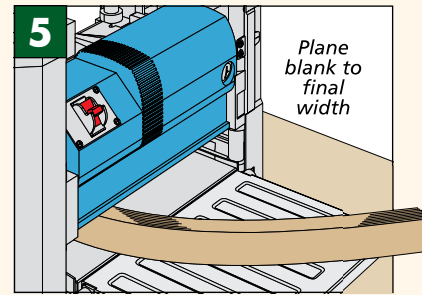
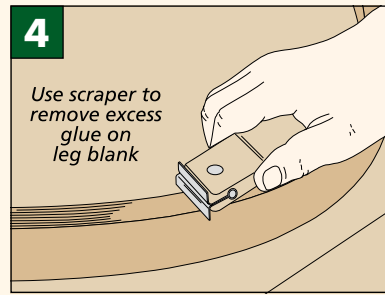

barely shave off the outside edge of the curve on each leg (Fig. 7a).

FINISHING TOUCHES. To complete the legs, I moved to the router table and "softened" the edges using a $\frac{1}{8}$ " round-over bit. I rounded both the inside

and outside edges, avoiding the flattened face. Then I sanded the outside tip of the bottom of each leg to match the round profile. Now, just give the pieces a final sanding and they're ready to assemble.

BUILD THE BENDING FORM

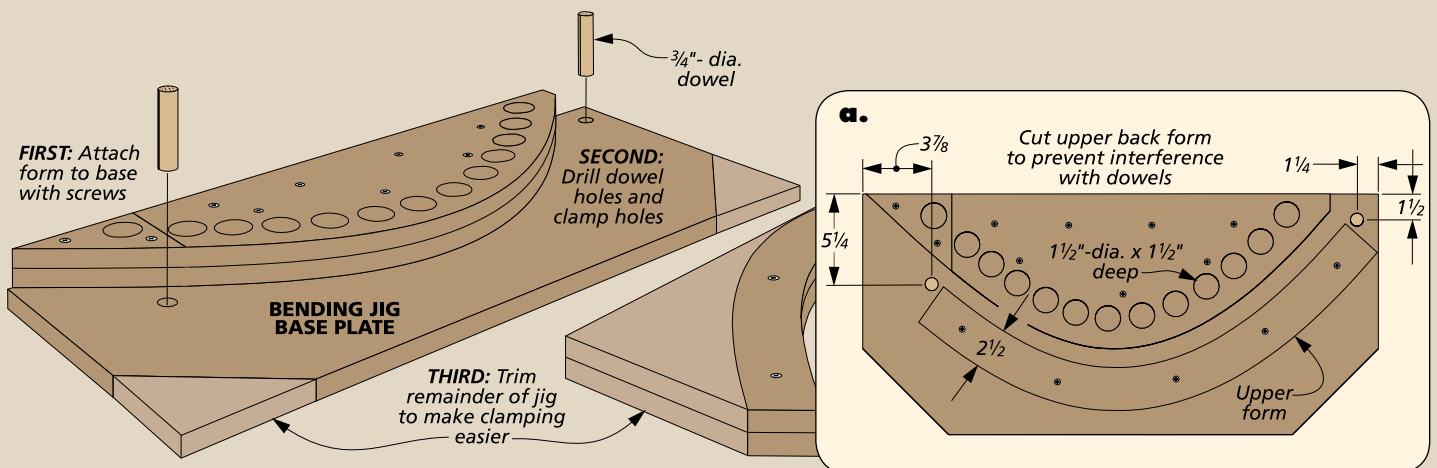

Add a Base. Mount the inside form to the base using screws. Then drill a series of $1\frac{1}{2}$ "-dia. holes for clamps. Also add two $\frac{3}{4}$ "-dia. holes for the dowels. Trim the corners to make it easier to tighten the clamps.

Complete the Form. Cut the outside part of the form to a uniform width to provide even clamping pressure. Then spray on a coat of finish and wax both parts of the form.

Adding the Top & Center Block

With the legs complete, the next step is making the top. You'll need to have it ready before joining the legs so you can use it to keep the assembly square.

A ROUND TABLETOP. As you can see in the illustration at right, the top is glued up from narrower boards. It's a pretty straightforward assembly, but you'll want to take the time to align your stock for the best grain match. You may also want to use cauls to keep the boards flat.

After you've smoothed and sanded the blank, you're ready to cut the top to size. To do this, I used a router and trammel. This allowed me to cut the circle and add a shallow groove for the inlay using the same setup just by adjusting the radius of the cut. You can see how I did this on the next page.

The last step is to glue the legs together to form the base. The box at the bottom of the page shows an easy way to assemble the base and keep it aligned and square.

Now just add a finish and the table is sure to find a good home next to your favorite chair.

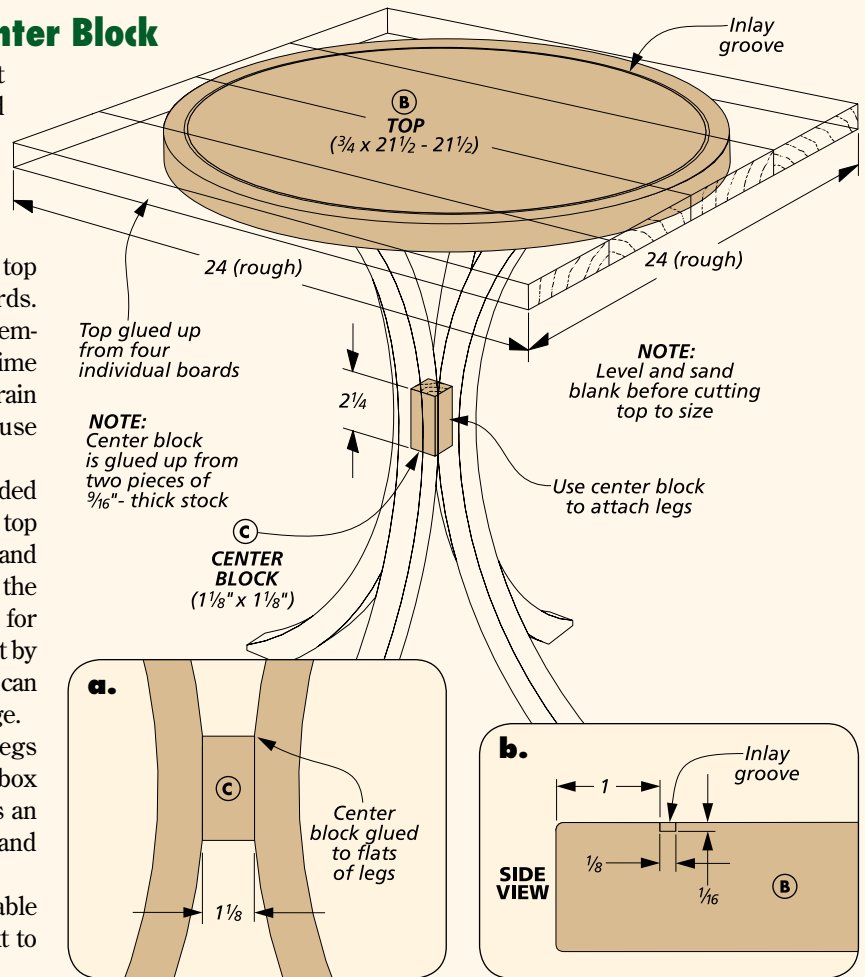

BASE ASSEMBLY DETAILS

The key to successfully assembling the base is to glue up the first two pieces flat and square. You can do this by laying two legs on your workbench and clamping a straightedge

to the bench top to use as a flat reference for the ends of the legs. Then it's just a matter of gluing the center block in place and clamping the assembly. After it's dry, drill and

counterbore holes in the ends, as shown in detail 'a.' Then attach the assembly with screws and use the tabletop to keep things square as you add the remaining legs.

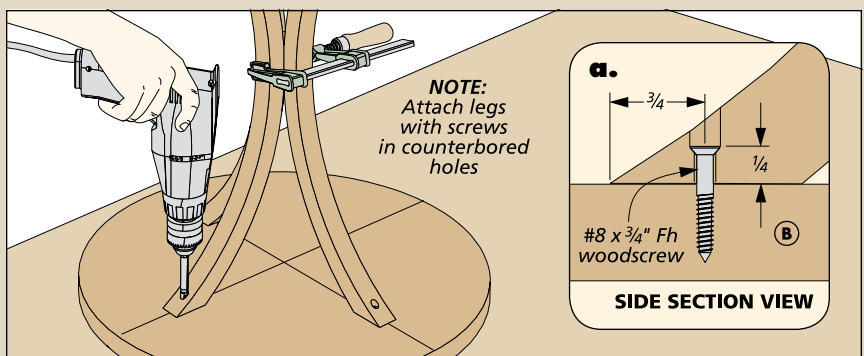
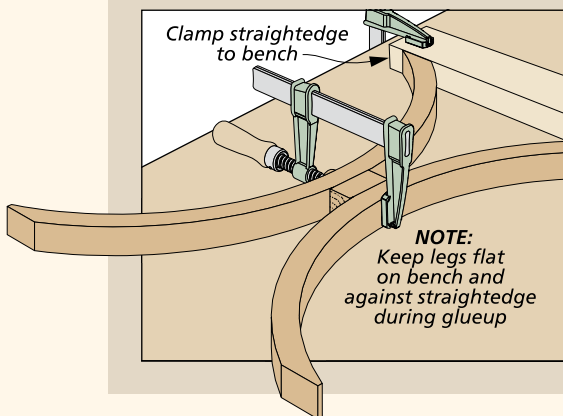

ROUT CIRCLES WITH A TRAMMEL

When I need to cut a circle, like the top for a table, I reach for my router and a trammel. There are a couple good reasons why I like this method. First, it's quick and easy to set up and make the cut. But, more importantly, it cuts a perfect circle and leaves a smooth edge that requires very little sanding.

THE TRAMMEL. The shop-built trammel I use is pretty simple to make. You can find the plans for it on page 9. It's very stable and accurate. And unlike most other trammels, this one doesn't require you to drill a hole in the workpiece for its pivot pin. The pin fits into a base that's held in place with carpet tape.

SETTING UP THE CUT. To get started, you'll need to elevate the workpiece off the bench so you can make a through cut. I used carpet tape and a couple pieces of scrap on the bench. Then I taped the workpiece to them (Fig 1.) Make sure to place the tape so it will hold both the top and the waste in place.

Now you need to find the center

of the workpiece. An easy way to do this is to draw intersecting lines from the corners, as shown in Fig. 1. Then line up those marks with the corners of the base, tape it in position, and you'll be assured of a centered cut.

ROUTING THE CIRCLE. With the base in position, the next step is to install a $\frac{1}{2}$ "-dia. straight bit in the router. Then, adjust the trammel to establish the diameter of the circle. Remember that you need to measure from the center of the pivot point to the inside edge of the router bit to get the right diameter. Then you just tighten the lock on the arm.

For a cut this deep, I always make multiple passes. This way I know the router won't bog down. In this case, I made three passes, lowering the bit $\frac{1}{4}$ " after each pass.

INLAY CHANNEL. To cut the groove for the epoxy inlay, all you need to do is move the adjustable arm $1\frac{1}{4}$ " in toward the center and install a $\frac{1}{8}$ "-dia.

straight bit. The epoxy will adhere to the channel very well, so you only need to rout a $\frac{1}{16}$ "-deep groove. You can rout this groove in a single pass. See the next page for details of how to add the epoxy inlay.

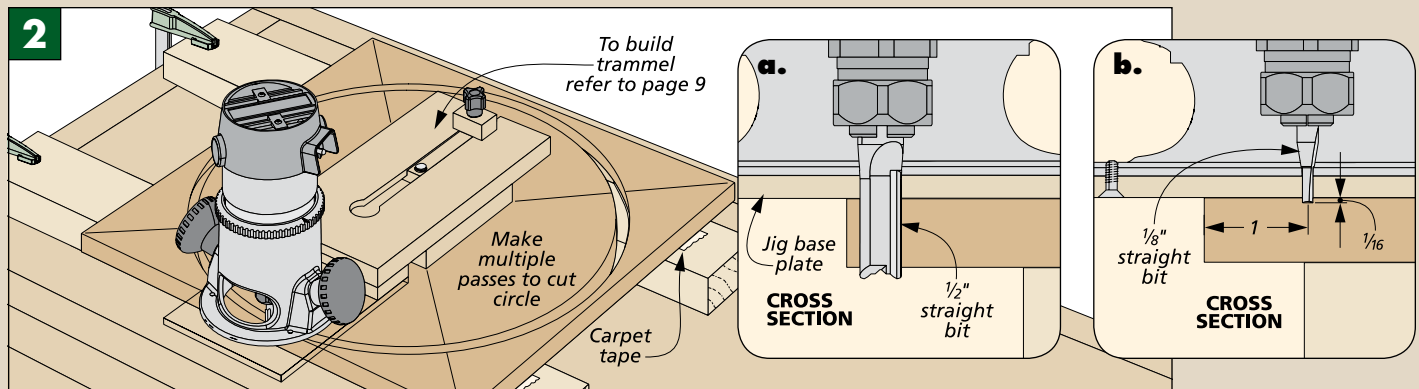
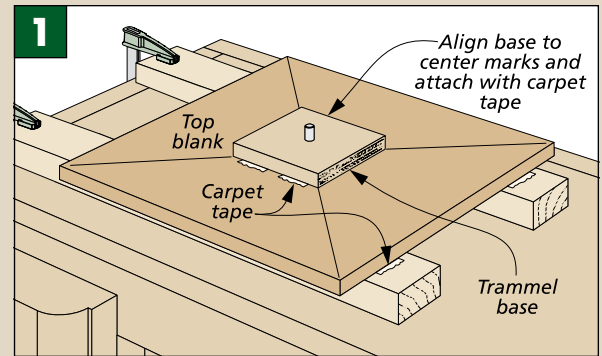

MATERIALS

- A Leg Strips (32) $\frac{1}{8} \times 1\frac{1}{8}$ - 32
- B Top (1) $\frac{3}{4} \times 21\frac{1}{2}$ - 21 $\frac{1}{2}$
- C Center Block (1) $1\frac{1}{8} \times 1\frac{1}{8}$ - 2 $\frac{1}{4}$

(4) No. 8 x $\frac{3}{4}$ " Fh woodscrews
Epoxy

CUTTING DIAGRAM

$\frac{3}{4}$ " x 6" - 96" Cherry (4 Bd. Ft.)



$\frac{3}{4}$ " x 6" - 96" Cherry (4 Bd. Ft.)

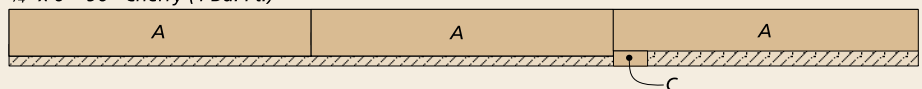

ADDING AN EPOXY INLAY

Give your projects an eye-catching inlay in minutes, not hours.



Traditional wood inlays are a great way to dress up the appearance of a project. The problem is cutting and fitting small, oddly shaped inlay pieces can be both difficult and time-consuming. An easy alternative is to use colored epoxy instead of wood. Epoxy will flow into just about any

shape, saving a lot of time and effort over conventional wood inlays.

For example, the table on page 1 features a round top with an inlay near the edge, shown above. Hand fitting small, curved pieces of wood into the circular channel would be a pretty tough task.

But you can get a similar effect by simply mixing up a batch of epoxy and adding a little color. Then you just apply the mixture into a shallow recess cut in the shape of your choice. With this technique, I was able to add a great-looking design detail without a lot of trouble.

GETTING STARTED. Like any inlay, the place to begin is by creating a recess. For the round tabletop, I used a trammel and a router with a $\frac{1}{8}$ " straight bit to cut the groove. And because epoxy adheres so well, the groove only needs to be $\frac{1}{16}$ " deep.

PREPARING THE WOOD. After you cut the

recess for the inlay, there's just one more step before mixing the epoxy. To prevent the epoxy from bleeding into the grain, it's a good idea to seal the wood first by spraying on a coat of lacquer. And to make it easier to remove any excess epoxy, rub a coat of wax on the surface of the wood.

MIX EPOXY AND COLOR. With the surface prepared, the next step is to choose an epoxy. I've found most brands work fine, but it's best to use a slow-setting epoxy. This way, you'll have plenty of time to get it in place before it starts to harden.

You can use just about any kind of coloring in epoxy, from aniline dyes to the black furniture powder I used on the table top. You'll just want to avoid colors that are soluble in the type of finish you'll be adding to the piece. For instance, if you're planning to use a water-based finish, stay away from water-soluble colors or

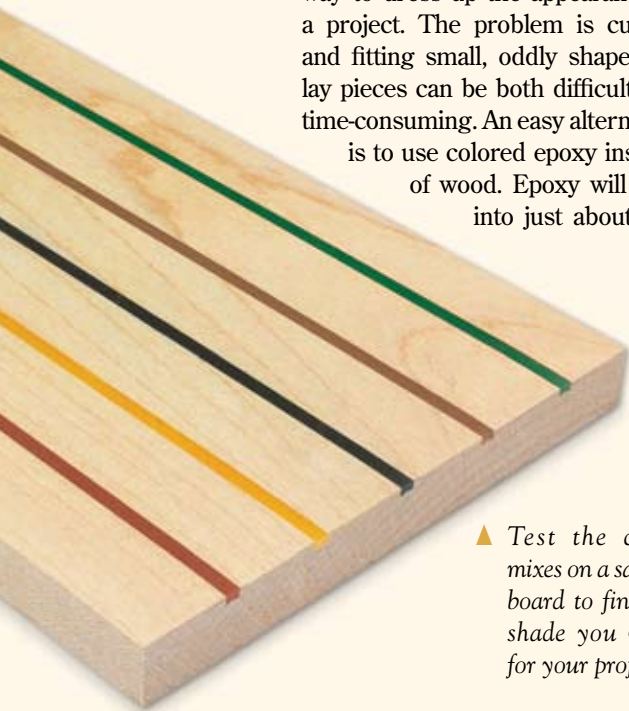

▲ *Test the color mixes on a sample board to find the shade you want for your project.*

WORKING WITH EPOXY

they will bleed when you apply the finish, even after the epoxy cures.

It's a good idea to mix up a few batches and test them on scrap pieces first. Then you'll get a feel for how well the epoxy works into the grooves. You can also experiment with different coloring agents to find the right mixture for the inlay. Note: I used a slow-set, two-part epoxy mixed with some Behlen's furniture powder for color.

APPLYING EPOXY. When you've found the shade you like, you're ready to start filling in the inlay. You can see the step-by-step process in the box at right. If the epoxy mixture is thin enough, you can draw it into a syringe and then simply squeeze it into the recess. I like this method because it gives me better control. And it also makes cleaning up the excess a lot less hassle.

If the mixture is too thick for a syringe, you can press it into the recess using a thin piece of scrap wood or plastic. Just be sure to add enough so the epoxy remains slightly proud of the surface.

CLEANING UP. Since you waxed the surface, the overflow will come off pretty easily with a sharp chisel. The bottom two photos at right show you how to clean up the epoxy and fill in any exposed air bubbles. You can remove the wax with mineral spirits. Then, after a final sanding to remove the sealer coat of lacquer, you're ready to add a finish. Using this simple technique, you'll find even the most intricate inlays are possible.



▲ To make removing the excess epoxy easier, first apply a coat of lacquer to seal the grain and then rub on a coat of wax.

There are a couple things to keep in mind when working with epoxy. First, it will bond to just about anything, including your skin. So I always wear rubber gloves when mixing and applying epoxy. Second, the resins not only smell bad, but can cause

allergic reactions in some people. So it's a good idea to work in a well-ventilated area. The same rule applies for sanding the hardened epoxy. The dust can be a real irritant, so use a good dust collector on your sander and wear a mask.

1 Start by mixing the epoxy according to the manufacturer's instructions (usually, equal amounts of resin and hardener). Then mix in the color. Stir the epoxy gently to minimize air bubbles.



2 A disposable plastic syringe makes it easy to apply the epoxy. You can cut the plastic tip to fit the size of the groove. Make sure to overfill the groove a little bit to allow for some shrinkage.



3 After about an hour, use a chisel to remove most of the overflow. At this point, the epoxy is rubbery. After it's cured (usually 8 hours) move on to a hand scraper, then sand the inlay smooth.



4 Holes caused by air bubbles in the inlay are almost unavoidable. But you can fill them using a drop of epoxy on a paperclip or toothpick. Then just sand again after the repairs are dry.



ROUTER TRAMMEL JIG

Cutting the round top for the table is an ideal job for a router and a trammel jig. It not only cuts a perfect circle but allows you to rout the groove for the inlay. The problem is, most trammels require a hole in the center of the workpiece for the pivot point. The design of this trammel solves that problem.

If you look at the photo, you'll see that the trammel is made up of a slotted adjustable arm that fits over a base. The base is secured to the workpiece with carpet tape. A pivot pin in the base allows the adjustable arm to rotate (see the drawings below).

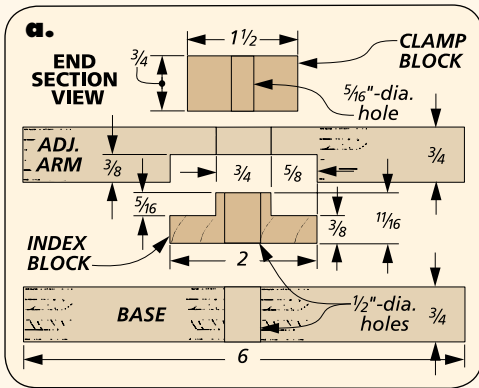

I started by making the adjustable arm. A dado blade cut in the table saw forms the

groove on the bottom of the arm. I drilled the hole at the end of the slot and then cut out the waste with a jig saw (detail 'b').

The base comes next. There's nothing tricky about it. It's a square piece of plywood with a center hole for the pivot pin.

The T-shaped index block comes next. The goal is to make it fit in the grooved slot in the adjustable arm (detail 'a'). A small piece of hardwood acts as the clamping block when adjusting the radius of the jig. The star knob and threaded insert complete the adjustment assembly.

Finally, add an acrylic baseplate to your router. I used my router's factory baseplate as a pattern for the screw holes. Fasten a spacer to the adjustable arm, then you can attach the baseplate to the spacer. All that's left is to attach your router.

