



THANK YOU!

You have successfully downloaded your *Woodsmith* project plan.

▶ [Go to Page 1](#)

Learn More About Routers...at PlansNOW.com



Inside Look at Router Bits

We'll clear up the confusion in buying router bits with an in-depth look at how bits are designed, what types are available, and which projects are best suited for a particular style bit.

▶ [Download Today at PlansNOW.com...\\$5.95](#)



Bonus Plan: Build a Router Bit Cabinet!

Step-by-step plans for building a router cabinet for your shop. Features a sturdy platform for making bit changes and router adjustments. A cutaway shelf lets you store your router in an upright position without removing the bit.

You Can Build it...at PlansNOW.com



Adjustable Dado Jig

Perfect dados every time without using a straight edge!



Queen Anne End Table

Build a matching end table for coffee table featured in show.



Top 5 Router Jigs

Easy-to-build jigs for cutting circles, mortises, and more!

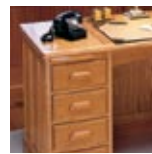

Pedestal Desk

Early 1900s style adds classic beauty to your home office.



Get the Most from Your Router!

NEW from the editors of *Woodsmith* magazine! Discover the shop-tested tips and hands-on techniques that will give you the results you want. They're all in this 100-page, softcover book — packed with hundreds of color photos and illustrations to guide you!

▶ [Order Today at WoodsmithStore.com](#)

**ONLY
\$9.95
FREE SHIPPING**



Woodsmith **PLANS**

CHERRY ROLL-TOP DESK



CHERRY ROLL-TOP DESK

A tambour door is only part of what makes this desk special. It also features a simple, classic shape and straightforward construction.



Sometimes the more obvious things tend to hide the important ones. Take this roll-top desk. Your eye is automatically drawn to the tambour door. There's just something about a door that opens and closes without swinging on a hinge. But you really need to look past the door to see what makes this desk a special project to build.

For one thing, there's the desk organizer hidden behind the door. Normally, an organizer is built as an integral part of the desk. But this one is designed as a totally separate project that can fit on *any* desk. Yet once it's completed, it slides easily into place under the tambour door.

Another example is the desk hardware — or more accurately, the lack of it. What you have here is a classic

“S-shaped” or double-curved roll-top desk which requires virtually no hardware (just a few woodscrews).

Or take a look at the design features. Sure, the decorative cutout on the bottom edge of the front rail is appealing. But at the same time, it provides additional clearance when sitting down to write at the desk. And the tapered legs give the desk a light, graceful appearance.

But the most important feature of making this roll-top desk is how easy everything goes together. I credit this to a good design. Right from the start, when cutting the tapered legs to gluing the slats to the canvas for the tambour door, the straightforward construction went like clockwork. I guess you can't ask for anything more.

Construction Details

Overall Dimensions:
42¹/₂" x 43" x 24"

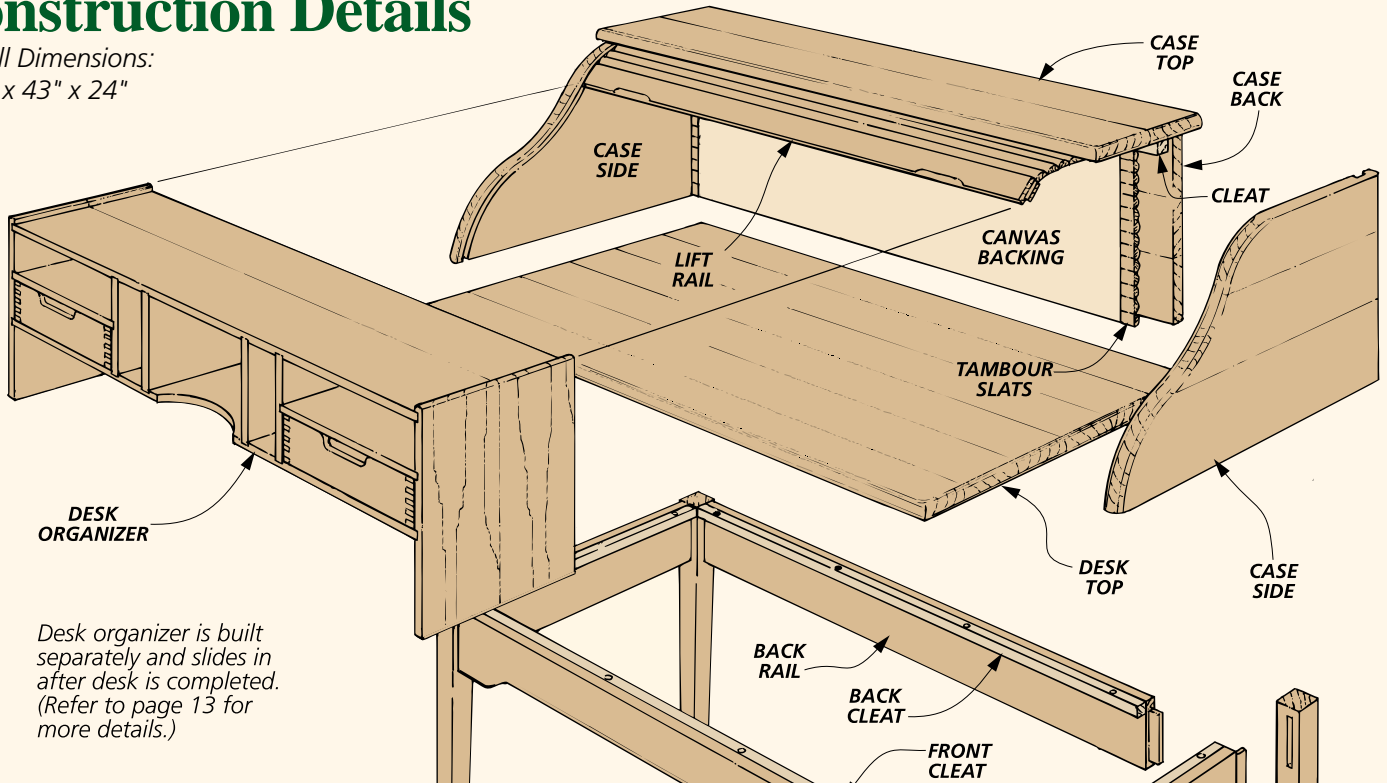

Desk organizer is built separately and slides in after desk is completed. (Refer to page 13 for more details.)

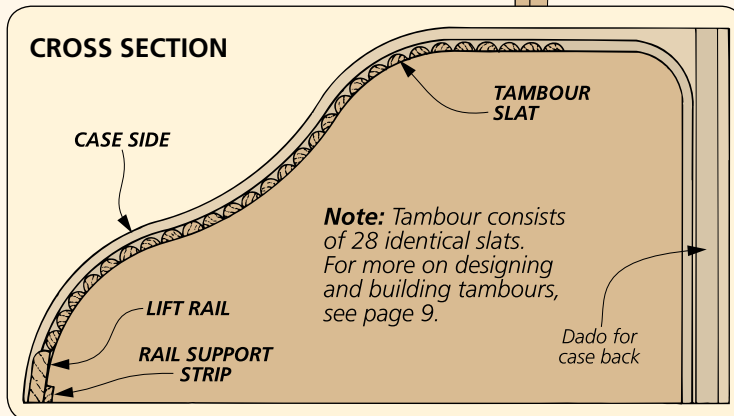

All four sides of each leg are tapered

CUTTING DIAGRAM

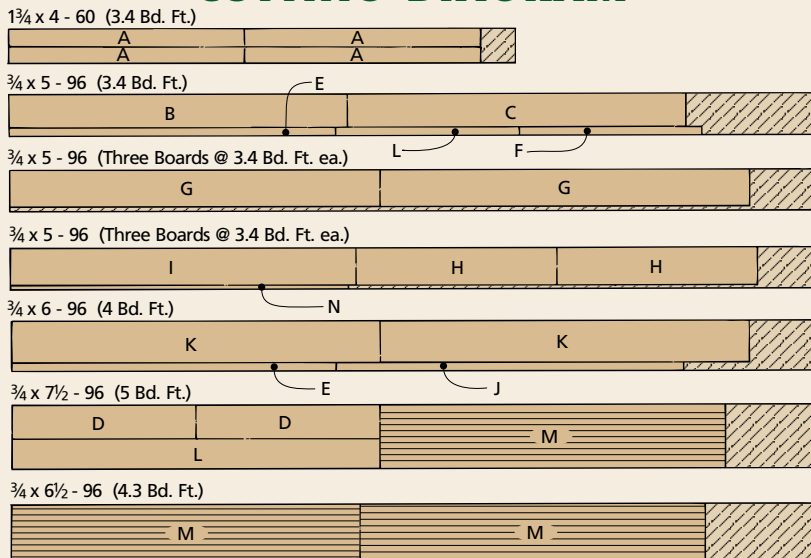

MATERIALS

- | | |
|---------------------------------|---|
| A Legs (4) | 1 ³ / ₄ x 1 ³ / ₄ - 27 ¹ / ₄ |
| B Front Rail (1) | 3 ¹ / ₄ x 4 - 40 |
| C Back Rail (1) | 3 ¹ / ₄ x 4 - 40 |
| D Side Rails (2) | 3 ¹ / ₄ x 4 - 21 |
| E Frt./Bk. Cleats (2) | 3 ¹ / ₄ x 3 ³ / ₄ - 38 ¹ / ₂ |
| F Side Cleats (2) | 3 ¹ / ₄ x 3 ³ / ₄ - 19 ¹ / ₂ |
| G Desk Top (1) | 3 ¹ / ₄ x 24 - 43 |
| H Case Sides (2) | 3 ¹ / ₄ x 12 - 23 |
| I Case Back (1) | 3 ¹ / ₄ x 12 - 40 ¹ / ₂ |
| J Cleat (1) | 3 ¹ / ₄ x 3 ³ / ₄ - 40 |
| K Case Top (1) | 3 ¹ / ₄ x 9 ¹ / ₂ - 43 |
| L Lift Rail (1) | 1 ¹ / ₂ x 1 ³ / ₄ - 40 ³ / ₈ |
| M Tambour Slats (28) | 5 ¹ / ₁₆ x 3 ³ / ₄ - 40 ³ / ₈ |
| N Rail Support Strip (1) | 1 ¹ / ₄ x 1 ¹ / ₂ - 39 ⁷ / ₈ |

Base

The base for this roll-top desk is built like a simple table. There are four legs and a top joined by some rails. I started work on the base by making the legs.

LEGS. These legs (A) start out as 1³/₄"-square pieces of 8/4 stock cut to a finished length of 27¹/₄", see drawing at right and leg detail at left. At one end, I marked the location for a pair of 1/4"-wide mortises to hold the tenons cut later on the rails, see Fig. 1. These mortises are cut on adjacent faces. But what's a little different here is they aren't centered on the leg. Instead, they're offset by 1/2" from the outside edge, see Fig. 1a.

To cut the mortises, I used a Forstner bit and drilled overlapping holes 13/16"-deep to remove most of the waste. This depth provides a little extra clearance for the 3/4"-long tenons on the ends of the rails. Since the bit cuts a clean, flat-bottom hole, it only takes a few minutes to square up the ends and clean up the sides of the mortise with a chisel.

TAPER. Now to make the legs look more graceful, I cut a taper on all four sides, as you can see in Fig. 2 and in the leg detail at left.

RAILS. After tapering the legs, set them aside until the rails are completed. The rails that hold the legs together are identical in width (4"). But their lengths are different.

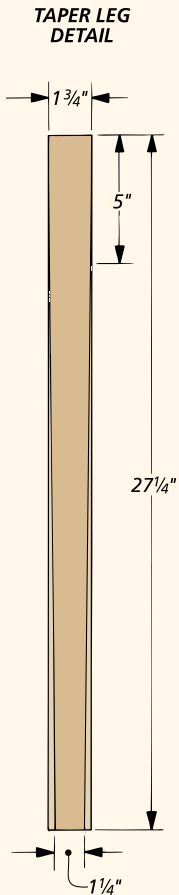
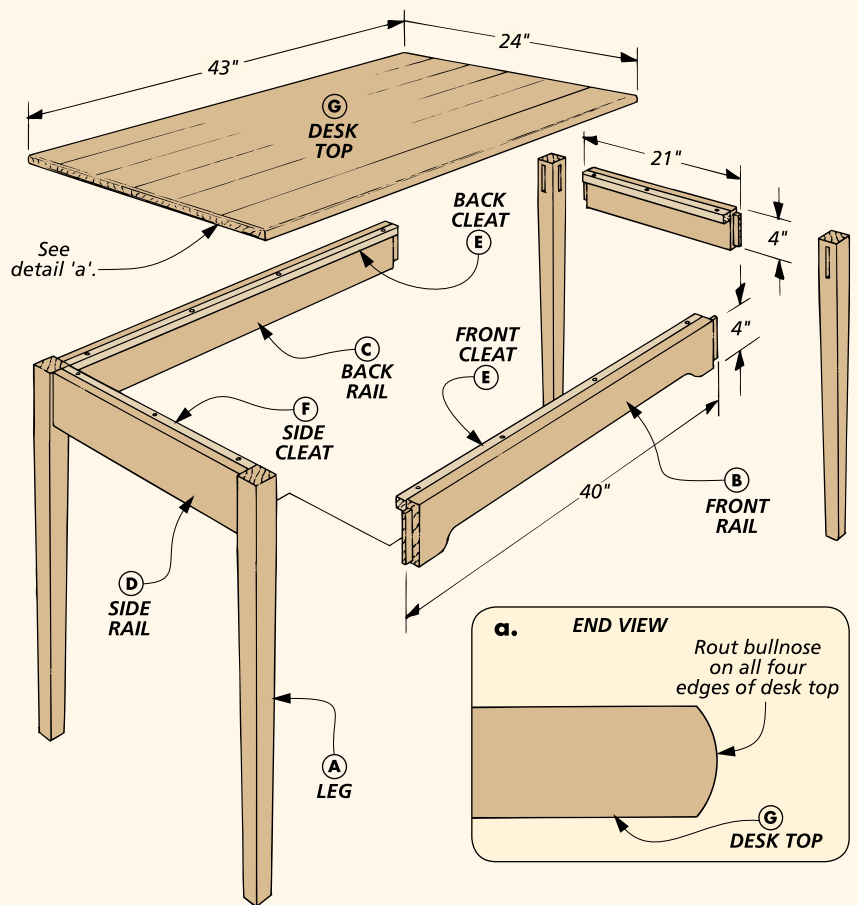

The front rail (B) and back rail (C) are 40" long, while the side rails (D) are only 21" long, see exploded view.

Next, I cut a 3/4"-long tenon on each end of all the rails. This tenon is centered on the thickness, but there's really no trick to doing this. Just flip the rail over between passes to remove stock from both sides.

But to make sure the tenon fits snug in the mortise, you'll want to sneak up on the final thickness, see Fig. 3.

To complete the tenon on the rails, all that's left is to create a shoulder on the ends so the tenon matches the length of the mortise in the legs. To do that, 1/2" of the tenon is removed from both edges, see Fig. 3a.

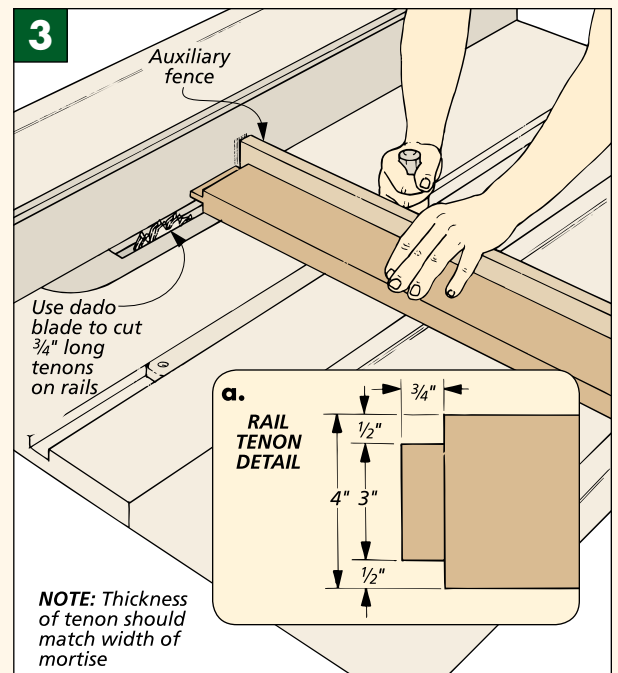
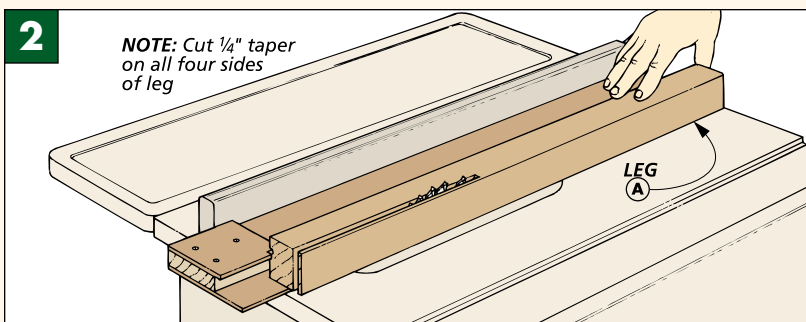
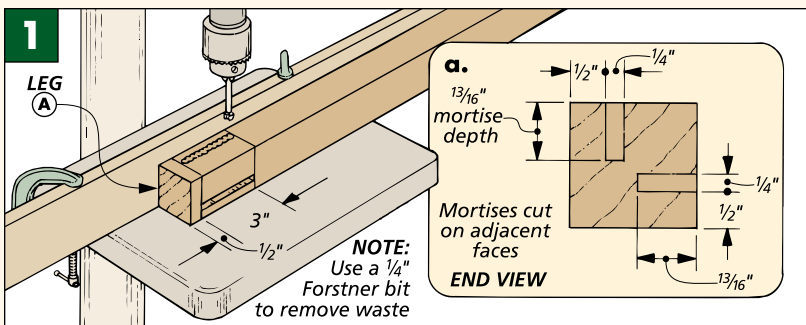

DECORATIVE CUTOUT. Up to this point the front and back rails are identical. But to provide a little extra clearance for sitting at the desk, I cut away part of the front rail, see drawing at right. To do this, simply lay out the curves at the ends of the rail and connect them with a straight line. Then remove the waste with a band saw and finish by sanding to the line.

BULLNOSE. The legs and rails could be assembled now, but I wanted to break the sharp corner and create a smooth edge. So I routed a bullnose profile on the bottom edge of all the rail pieces, see Figs. 4 and 4a. To do this, I used a $\frac{1}{2}$ " round-over bit raised $\frac{5}{16}$ " above the router table, see Fig. 4a.

ASSEMBLY. With the bullnose completed, the base can be glued together. To make this easier, I glued the legs and side rails first. Then I clamped the front and back rails between the side assemblies, see Fig. 5.

CLEATS. Next, I worked on making the cleats that hold the desk top in position. These are $\frac{3}{4}$ "-square pieces of stock with oversized shank holes drilled in them, see Fig. 6a. The **front** and **back cleats (E)** are the same length ($38\frac{1}{2}$ "), while the **side cleats (F)** are shorter ($19\frac{1}{2}$ "), see exploded view on previous page.

These cleats are simply glued to the desk rails. But to make sure the desk top sits tight against the rails, the cleats aren't flush with the top edge, see Figs. 6 and 6a. Instead, they're set a little below the edge to create a small clearance gap.

DESK TOP. Next, I glued up several boards to create a solid wood blank for the **desk top (G)**, see Fig. 7.

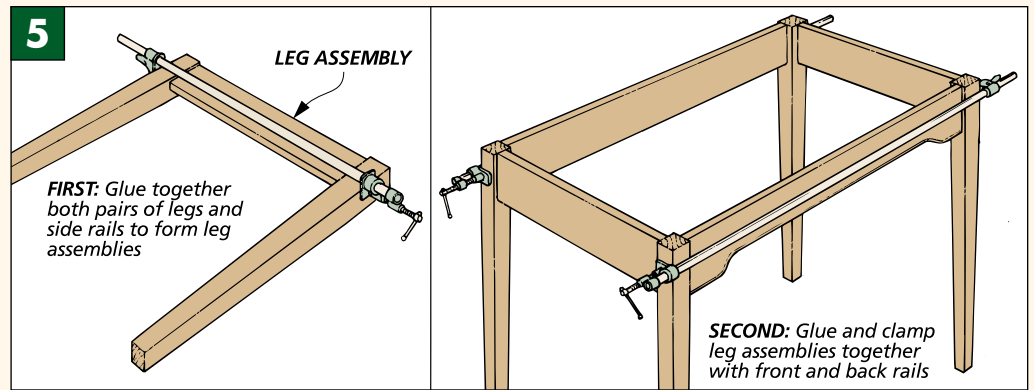
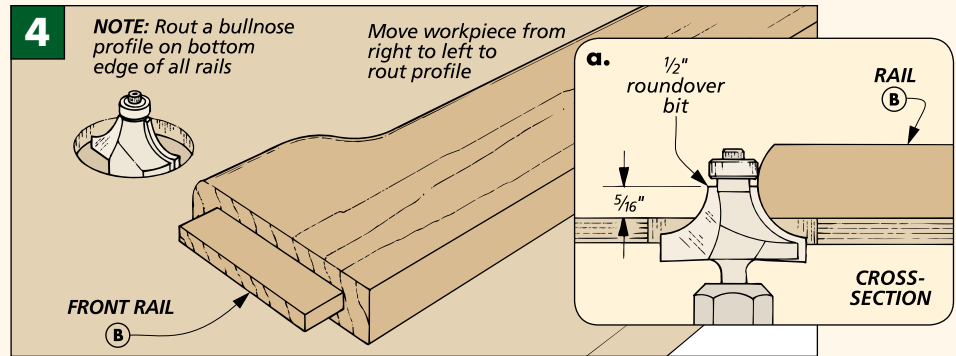
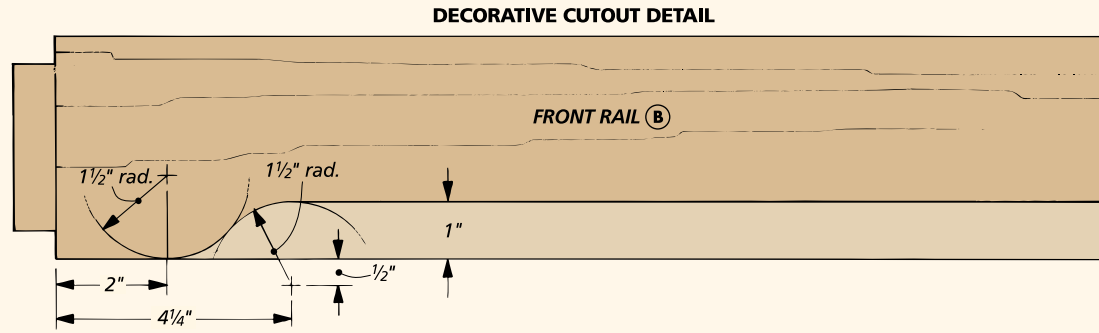

Then after cutting the top to finished size (24 " x 43 "), rout a bullnose profile on all four edges. Here again this required a $\frac{1}{2}$ " round-over bit, but this time I used a hand-held router.

Finally, it's a good idea to temporarily attach the top to the base, see

Fig. 7. It will help strengthen the base as you move it around in the shop. You can go ahead and drill the holes, but don't put in all the screws just yet. Later, you'll have to remove the desk top before the roll-top case and tambour door can be installed.

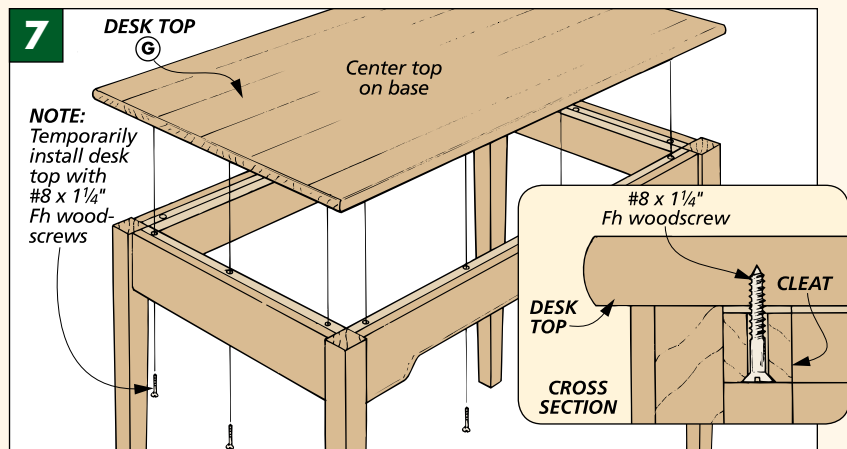
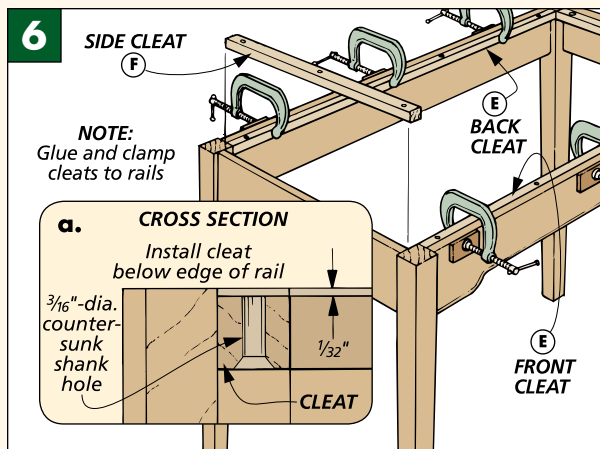

Roll-top Case

After completing the base, I turned my attention to building the roll-top case. It consists of two identical side pieces held together by a top and back panel, see drawing at right. I started on the case by working on the sides.

BLANKS. The sides are glued-up blanks that are cut oversize (mine were 12½" x 24"). Once the glue dries, the "S-shape" for the side pieces can be drawn on the blank.

SIDE TEMPLATE. An easy way to do this is by making a template first, see template detail at right. Draw the shape on a piece of hardboard, cut it out, and sand the edges smooth.

Now the template can be used to transfer the profile to the glued-up blanks. Just trace around it and cut out the **case sides (H)**. To make sure these pieces are identical, I stuck them together with double-sided carpet tape and sanded them smooth.

GROOVE TEMPLATE. Once the side pieces are sanded, the next step is to rout identical grooves on the inside face of each piece. This ¼"-deep groove follows the shape of the case side and provides a channel for the slats and lift rail of the tambour door to slide in as it's opened and closed. To make the door slide smoothly, the grooves have to be positioned in the same location on both pieces.

So I used a template again, but this time to guide my router. It guarantees that the grooves will be positioned

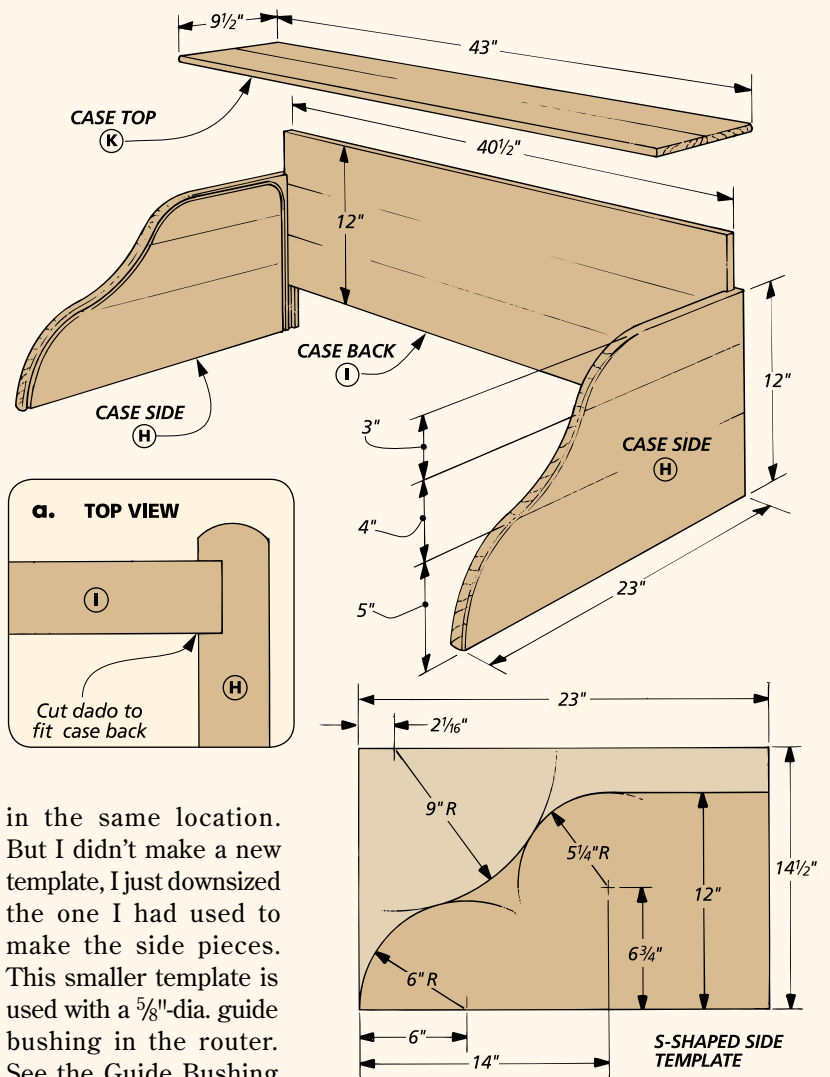

in the same location. But I didn't make a new template, I just downsized the one I had used to make the side pieces. This smaller template is used with a 5/8"-dia. guide bushing in the router. See the Guide Bushing box at lower left.

How much smaller is this template? There are a few things to keep in mind: How far the groove is from the edge. The groove width. And the distance from the edge of the router bit to the outer edge of the guide bushing. In

my case, this ended up at 7/8".

Now use a compass set at 7/8" and follow the existing shape of the template along the front edge and across the top, see Fig. 8. But the back edge is a little different.

GUIDE BUSHING



▲ A 5/8"-dia. guide bushing installed in the router base rides against the template when routing the groove. Hold the bushing tight against the template for an exact copy of the profile.

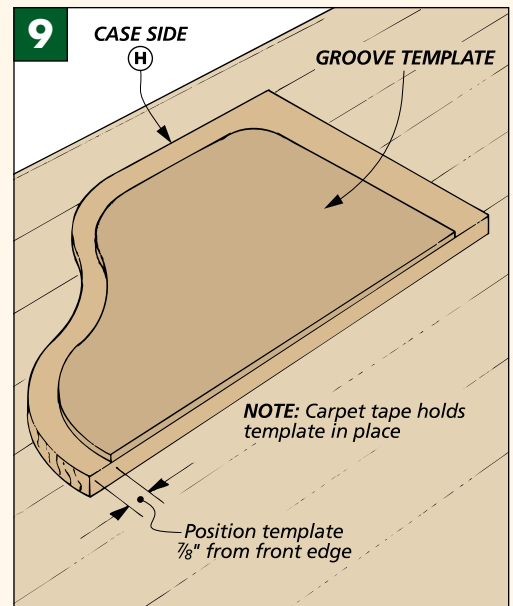
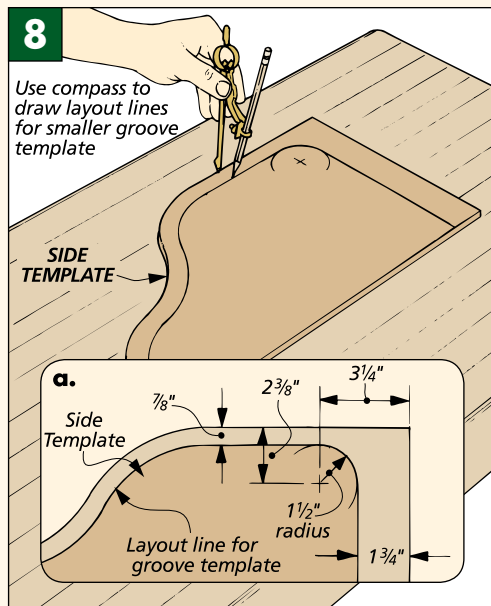

Here you need a 1½" radius so the door can slide around the corner. And for clearance between the door and case back, the distance changes to 1¾", see Fig. 8a. Once the lines are drawn, cut the template to size and sand the edges smooth.

ROUTING GROOVE. After making the template, it's a breeze to use it. Just position the front edge 7⁄8" back from the front edge of the side and flush along the bottom, see Fig. 9.

To make sure the template doesn't move, I used several strips of double-sided carpet tape to hold it securely in place. Shop Note: While you're at it, it's also a good idea to add a backing board where the bit exits the groove, see Fig. 10. This keeps the edge of the board from chipping out.

I used a hand-held router and made two passes to reach the ¼"-depth. You could do it in one pass. But a light cut makes it easier to keep the bushing tight against the template.

BULLNOSE. After routing the grooves, I switched to the router table to rout a bullnose profile on all the edges except the top. I didn't want a radius here so the case top would sit nice

and flat. To do that, just measure out about 9" from the back edge and make a mark where you want to stop the profile, see Fig. 11.

BACK DADO. To complete the side pieces, a dado is cut along the back edge to hold the case back, see Fig. 12. This ¼"-deep dado is cut to match the thickness of the back panel.

CASE BACK. With the dado cut, the case back (I) is added next to join the sides. This glued-up panel matches the height of the sides (12") and is glued in the dado, see Fig. 13.

But before the glue dries, it's important to check that the sides are perpendicular to the back. If not, the tambour door may bind in the opening once it's installed.

CLEAT. One more thing to add to the case before moving on to the case top is a cleat (J), see Fig. 13. It fits between the sides and is glued and clamped to the back. Just like the cleat on the base, it isn't glued flush with the top edge, see Fig. 13a.

CASE TOP. All that's left to complete the case is building the case top (K). Like the side and back pieces it's also a solid wood panel with a bullnose

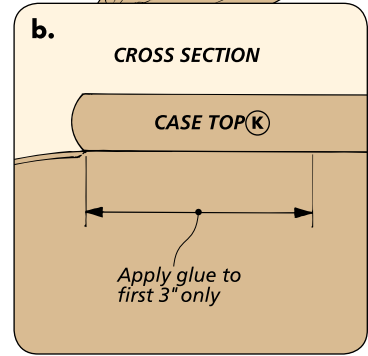
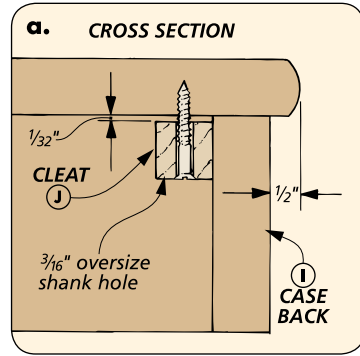
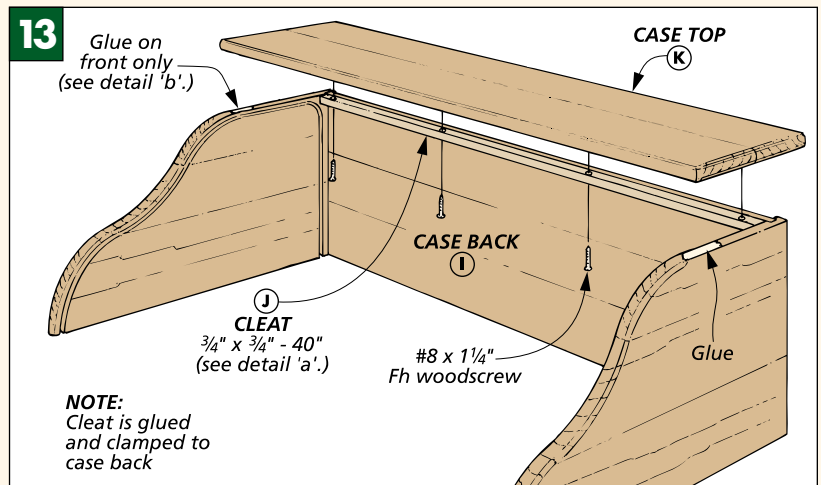
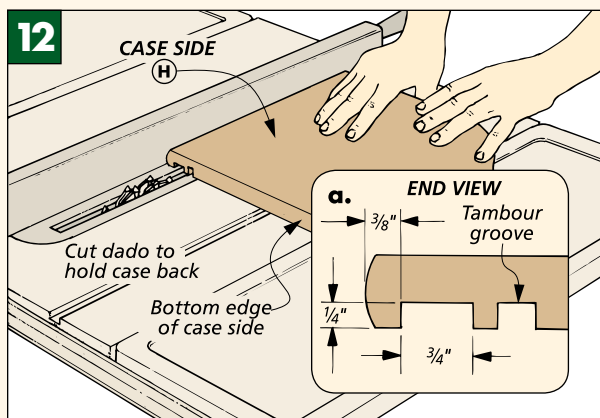
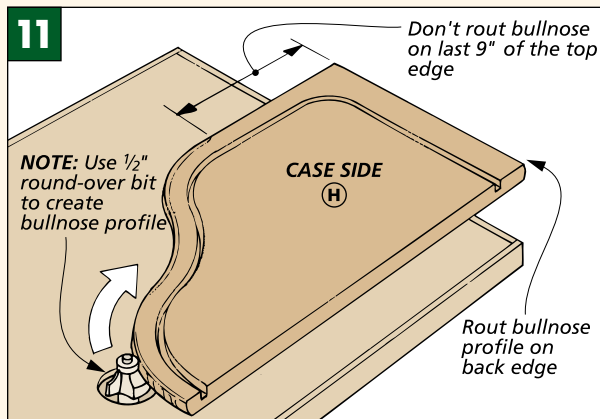
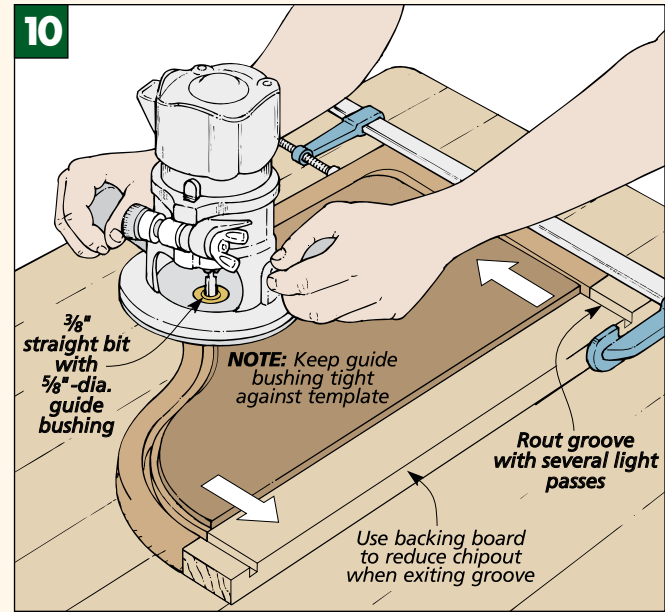

profile routed on all the edges.

The top is attached to the case with screws and glue. The screws secure the back edge, see Fig. 13a. But the front edge is glued in place in just a couple spots, see Fig. 13b. If you glued the whole edge, it would prevent the solid top from moving when the humidity changes.

Tambour Door

After putting the case together, the next step is building the tambour door that fits inside. Tambour doors are basically all the same. There's a lift rail to open and close the door, slats that make up the body, and a fabric "hinge" on the backside that holds everything together, see drawing at right.

LIFT RAIL. I started on the door by working on the **lift rail (L)**. It's a wide piece (3") of 1/2"-thick stock cut to finished length. To determine the length, just measure the distance between the tambour grooves in the case sides and subtract 1/8" for clearance. (My rail was 40 3/8" long.)

CUTOUTS. Next, a pair of cutouts are routed in the front face of the lift rail, see drawing at right.

Just draw a couple lines on the front face to mark the location for the cutouts, see Fig. 14. Then use a hand-held router and a cove bit to create each recess, see Fig. 14a. Note: A wide piece of stock helps to keep the router steady during the cut.

BEVEL. Next, I ripped a 7° bevel on the bottom edge of the lift rail so it would sit flush on the desk top, see detail 'a' at right. Then rip the lift rail to its final width (1 3/4").

RABBET & ROUNDROVER. Now to complete the lift rail there's a little more work to do. First, the ends need to be thinner so they'll slide in the grooves in the case sides. This was taken care of by rabbeting both ends to create a 1/4" x 1/4" tongue, see Figs. 15 and

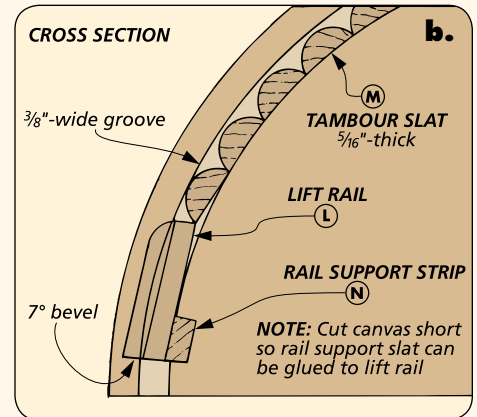
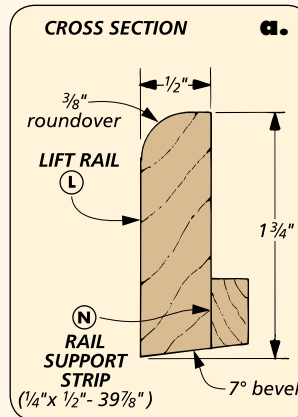
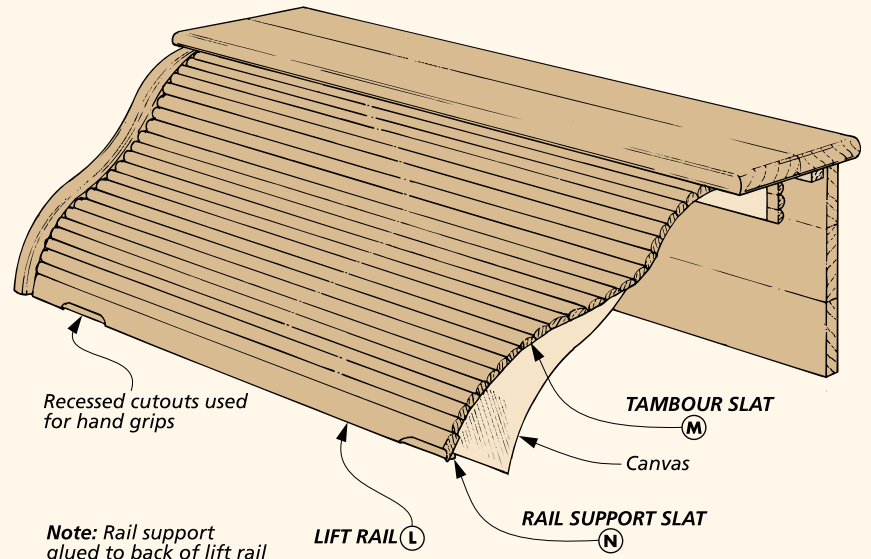

15a. Also, to match the profile of the slats, I used a 3/8" roundover bit to rout the top outside corner, refer to detail 'a' in drawing above.

SLATS. With the lift rail complete, I concentrated on the **tambour slats (M)**. For the roll-top desk, 28 slats the same length as the lift rail are

needed to complete the door. But I made a few extra so I wouldn't come up short if any twisted out of shape.

Making the slats is a two-step process. First, I used a roundover bit to create a rounded profile on the edge of the workpiece, see Figs. 16 and 16a. Then using a carrier board, it's

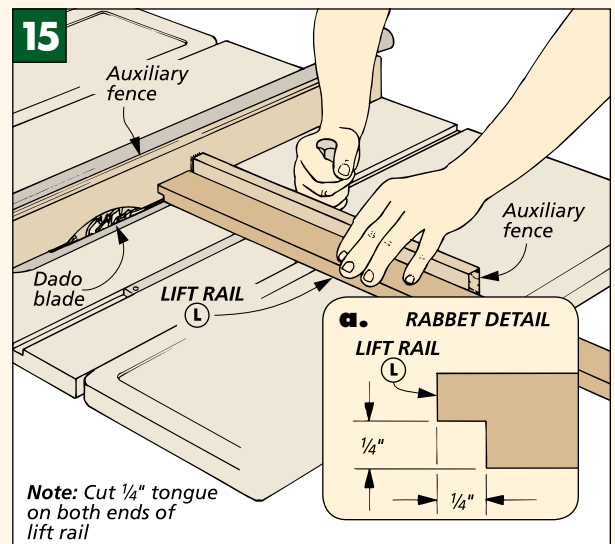
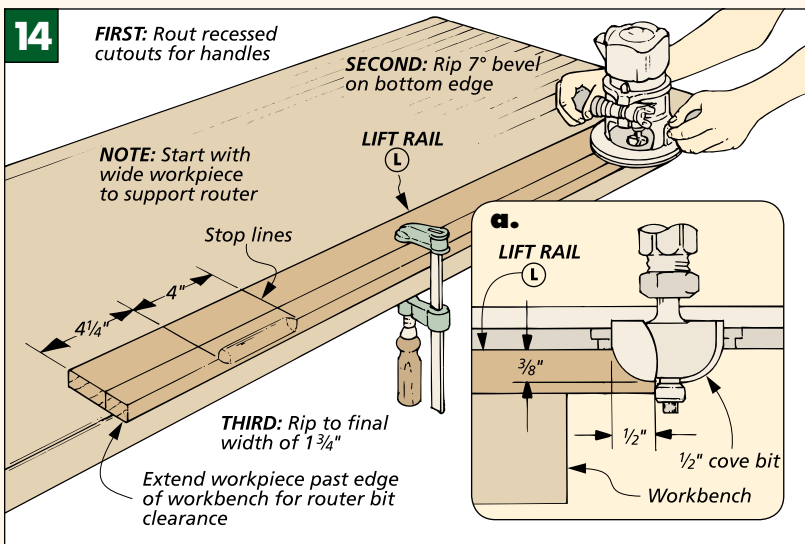

quick and easy to rip a thin slat off the edge, see Figs. 17 and 17a.

By adjusting the rip fence to clear the $\frac{5}{16}$ " notch on the end of the carrier board, all the slats will end up a uniform $\frac{5}{16}$ " thickness. A uniform thickness is important so the door slides freely in the groove. For more on cutting slats, refer to page 11.

GLUE-UP. Once you have your slats cut, both the lift rail and slats can be glued to a canvas backing. Refer to page 12 for gluing slats.

DRY ASSEMBLY. After the slats are glued to the canvas, it's a good time to check the fit of the door. I wanted to see if it slides freely in the groove. If there's a problem, refer to the troubleshooting tips on page 12. Also, since I planned on adding the desk organizer later (page 13), I checked the height of the opening (mine was 10").

RAIL SUPPORT STRIP. To complete the door, a **rail support strip (N)** is glued to the back of the lift rail, see details 'a' and 'b' in drawing on page 7. This strip gives you something to grip to close the tambour door. There's a 7° angle ripped on one edge to match the angle cut on the lift rail and it's sized to fit between the case sides ($39\frac{7}{8}$ ").

MOUNTING HOLES. Once the tambour door is complete, the desk could be

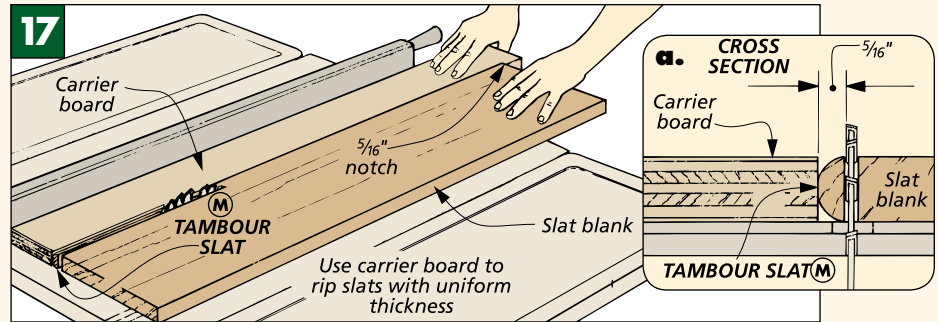
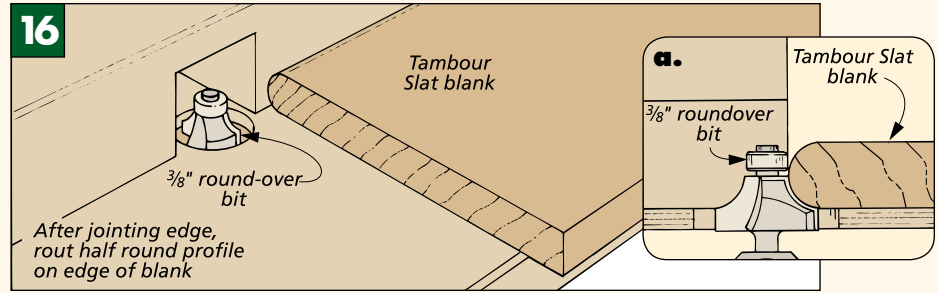

assembled. But to make finishing easier, I applied a couple coats of wiping varnish (like General Finishes) to the separate pieces. Note: You'll need to remove the desk top installed earlier. And it's a good idea to keep the finish out of the grooves in the sides.

When the finish is dry, the roll-top desk can be assembled. The first step is to install the case on the desk top. This meant drilling mounting holes through the desk top

and into the case sides and back.

I centered the case on the desk top and placed masking tape around the outside edges, see Fig. 18. When the case is removed, just measure in from the edge of the tape $\frac{3}{8}$ " and drill the oversize shank holes.

FINAL ASSEMBLY. Now the door can be installed into the case, and the case screwed to the desk top, see Fig. 18a. Finally, set the desk top on the base and screw it in place, see Fig. 19. □

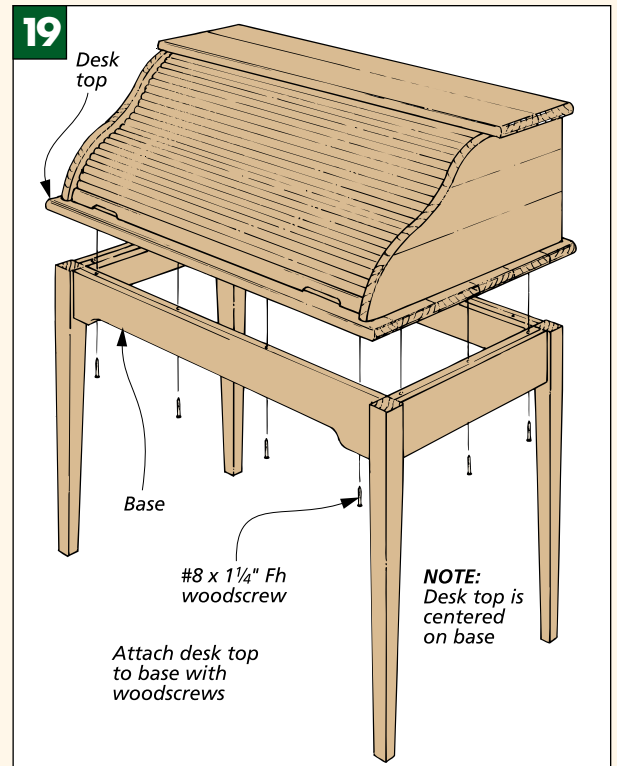
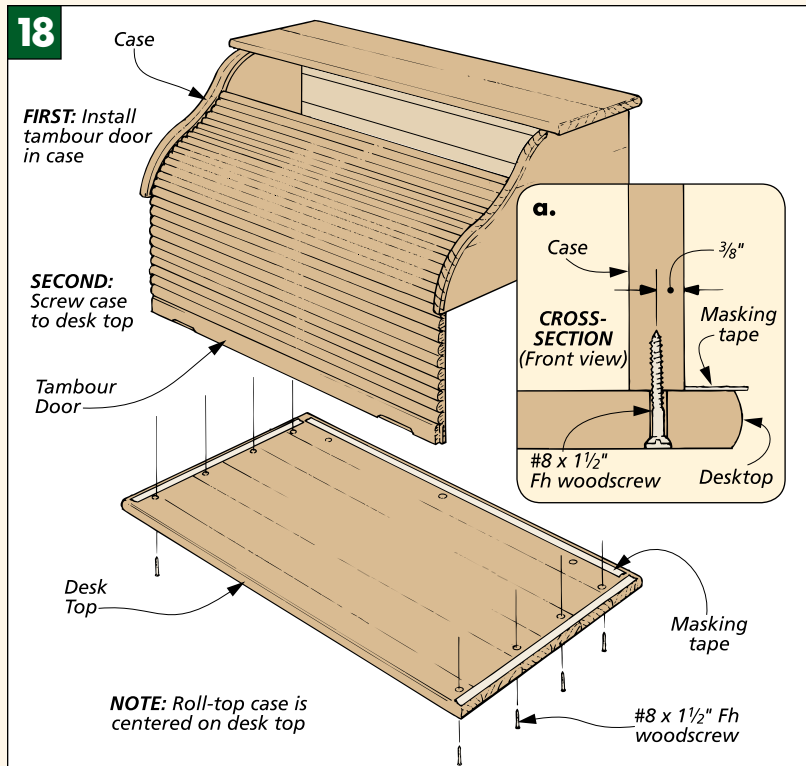

BUILDING TAMBOURS

Here are some design pointers and building tips that will come in handy when working on and installing tambour doors.

One of the things I enjoy about woodworking is there's usually more than one way to solve a problem. And maybe that's how tambour doors were invented. Someone needed a door that would store out of the way when open.

The "solution", a tambour or roll-top door, seems fairly obvious now. Make it flexible by gluing a bunch of thin slats to a piece of fabric. Then cut a groove for the pieces to follow so the door can slide out of sight inside its own cabinet. That's it. Nothing complicated about it.

Now a lot of people think tambour doors are a mystery. After all, there must be some trick in getting all those pieces to work together as a sliding door. But all you really need is a good design to follow and a little patience cutting and assembling the parts.

DESIGN SHAPE. So when building a tambour door, I find it's easiest to stick to a couple tried-and-true designs. These designs are straightforward and give me consistent results. They incorporate what I refer to as an "S-shaped" (double curve) or "C-shaped" (single curve) tambour, see Fig. 1.

Each design has some advantages over the other, depending on the application. For example, I like to use an S-shaped tambour when the project calls for a wide door (like the roll-top desk). This shape looks less bulky and

more graceful for a large tambour. Plus, adding the extra curve helps the thin slats resist sagging in the middle. And having a door with less sag means it will slide that much more smoothly.

On the other hand, when I need the maximum amount of storage space for a project, a C-shaped tambour is a better choice. It provides the largest usable space behind the door. This comes in handy when you need to store a large mixer or blender in an "appliance garage" in the kitchen.

TAMBOUR ANATOMY. Deciding which shape to use is the first step to building a tambour door. Once that's taken care of, the next thing to consider are the parts of the tambour. What this means is figuring out how the actual pieces of the door will be cut and put together.

All tambour or roll-top doors consist of the same three parts. There's usually a thick, heavier piece at the front (a lift rail), followed by a quantity of thinner pieces (tambour slats), all held together with a piece of fabric, see drawing on next page. The roll-top desk, for example, has a lift rail and 28 slats glued to a piece of canvas.

If there's one thing that's similar about all the tambour doors that I build, it's the fabric. I always use canvas. Usually this is a light to medium-weight artist's canvas

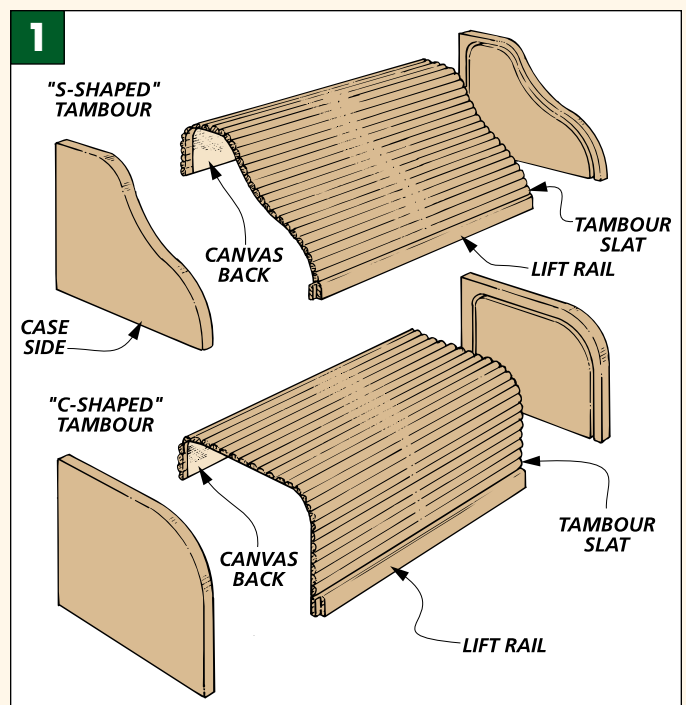

available at art supply stores. Some people like using a dark denim backing because it doesn't show between the slats. But whatever the material, it not only holds the pieces together, it also acts as the hinge. The canvas allows all the individual pieces to flex as the door slides through the groove.

But it takes more than a piece of canvas to allow a door to flex in more than one direction (like it has to for an S-shaped tambour). The real "secret" is the style (or profile) of the tambour lift rail and slats.

STYLE. The key to having a tambour flex is building in clearance between the slats. This can be easily accomplished by changing the slat profile. I wanted the door on the roll-top desk to move through some pretty tight curves. By rounding over the slats, they can flex or move back and forth as the door moves through the curved groove, see Figs. 3 and 3a. The greater the clearance between the slats, the tighter the curve the door can follow.

SLAT WIDTH. But there are a couple of other things that come into play to allow the door to slide smoothly through the groove. One is adjusting the width of the slat, see Fig. 4. A wider slat makes a sturdier door. But a wide slat can't slide through a tight curve. It's physically impossible. That's why you typically don't find slats wider than 1" on most tambour doors.

There is one exception to this: the lift rail located at the front of the door. Here you want a wide piece to take all the wear and tear of being pushed

and pulled as the door is opened and closed. It's traditionally cut wider and thicker to make it stronger (like on the roll-top desk).

Getting a wide piece like this to work in a groove doesn't require any woodworking magic. Simply reduce the thickness on the ends of the rail by cutting a rabbet to create a tongue, see Fig. 2. For the desk, this tongue was only 1/4"-thick so it could slide smoothly in the 3/8"-wide groove.

THICKNESS. When you reduce the thickness of a lift rail or slat, you can make it wider and still have it slide smoothly. This is because you've created more clearance around it. Of course you can go too far and make them too thin. Then on a wide door the slats could start to sag and even fall out of the grooves.

CLEARANCE. Finally, there's one other consideration for making tambour doors slide smoothly. You need to allow for clearance between the slat

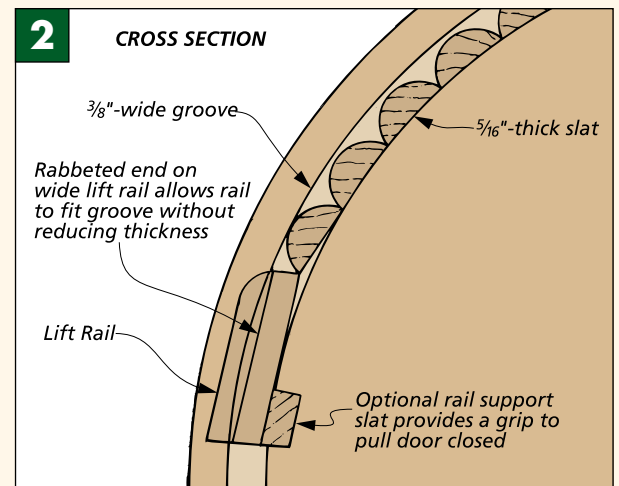
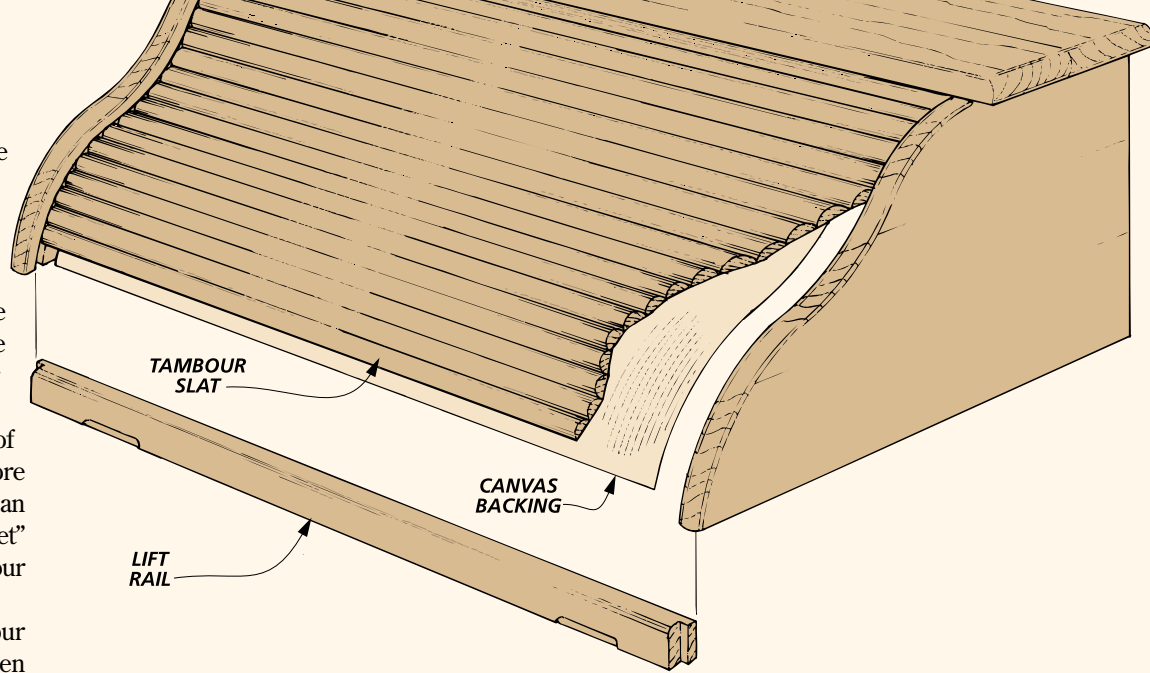

and the groove. You can't expect a 3/8"-thick slat to slide very well in a 3/8"-wide groove. The tambour door in the roll-top desk used 5/16"-thick slats in a 3/8" groove, see Fig. 2. This provided just enough clearance so the tambour door would slide smoothly but without rattling around when it moves.

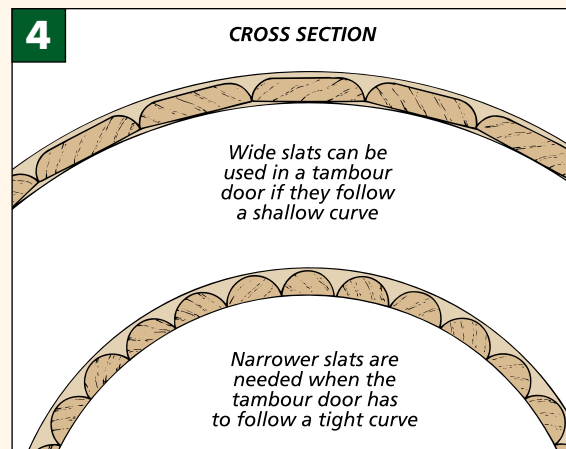
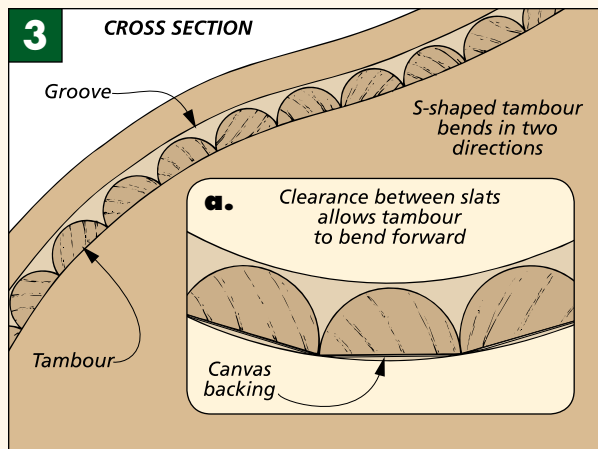

Okay, so now you know there's more to designing a tambour door than gluing some sticks to a piece of canvas. The next step is to put this information to use. For me, this means starting on the case panels that hold the door.

TAMBOUR CASE. The first step is to make the grooves on the sides that guide the door. They're mirror images of each other so the door doesn't bind as it's opened and closed.

The easiest way to keep these grooves aligned is by making a template, see Fig. 5. This way a guide bushing in a hand-held router can follow the template and rout the groove, see Fig. 6. As long as the template is installed in the same spot on both side pieces and the guide bushing stays tight against the template, the grooves will be identical.

LIFT RAIL. After routing the grooves, the lift rail can be built for the door. Just cut it to length to fit between the grooves and rabbet the ends so it slides easily in the grooves.

SLATS. Next I turn my attention to the tambour slats. I start with a wide piece of stock and cut several slats from it. First, rout the profile on one

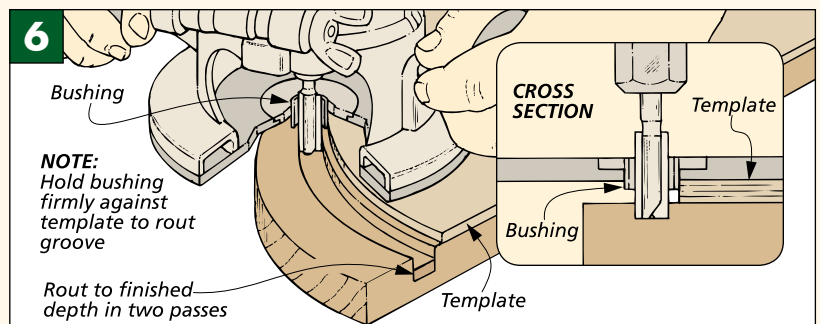
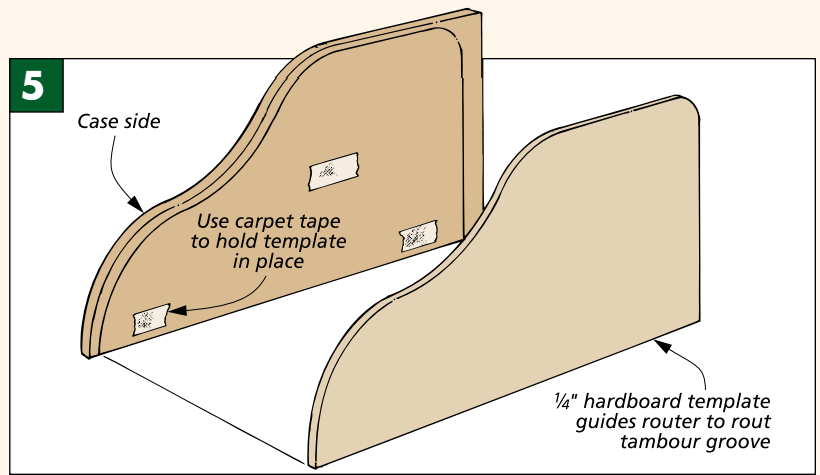

edge, see Figs. 7 and 7a. Then switch to the table saw to rip the slats from the edge of the board.

To make cutting these thin slats safer, I use a carrier board with a

small notch cut at one end that matches the thickness of the slats, see Figs. 8 and 8a. This way as the slat is cut from the blank, the carrier will push it safely past the blade.

I also like to number the slats as they're cut, see Fig. 8b. That way they can be reassembled for the best color and appearance. And while you have the saw and router set up, make some extras. There's always a few slats that twist or bow and need replacing.

GLUE-UP. To hold the slats and lift rail together, they're glued to a piece of canvas. In this case, I don't use yellow glue. I prefer contact adhesive.

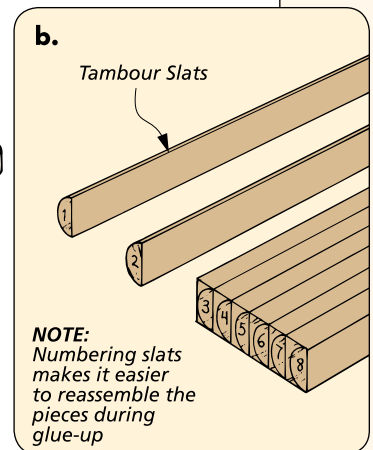
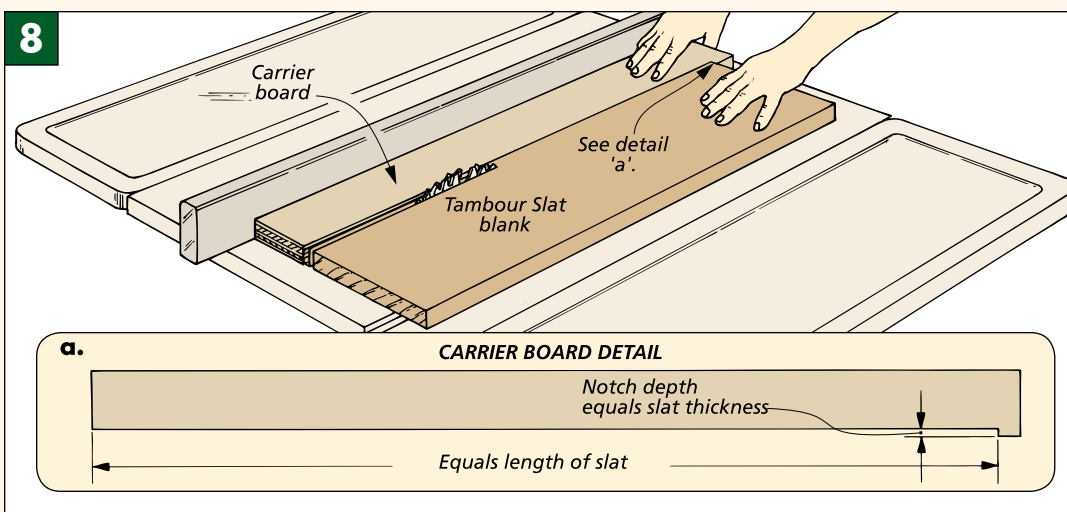
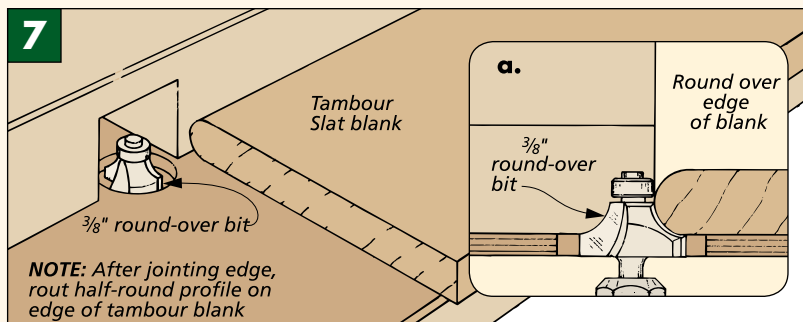

A small roller spreads the adhesive quickly, and it's not nearly as messy. Plus, there's no squeeze-out, and you don't need to worry about clamps.

Now before you start, trim the canvas so it's narrower than the slats. This keeps the canvas out of the groove. Then use a couple coats of adhesive for a good bond. This is easy on a big piece of canvas. But it can be tedious work on the narrow slats. So I temporarily assemble a few slats by taping the ends, see Fig. 9.

The tape holds the slats together so there's a large surface to work on. And once you remove it, the ends are free of glue. (Glue on the slats would keep them from sliding freely.)

ASSEMBLY. Now the challenge is getting the slats and lift rail installed on the canvas so they're square to each other. Here's where an assembly jig helps, see Fig. 10. This jig is just a couple of pieces of scrap screwed to a piece of plywood at right angles

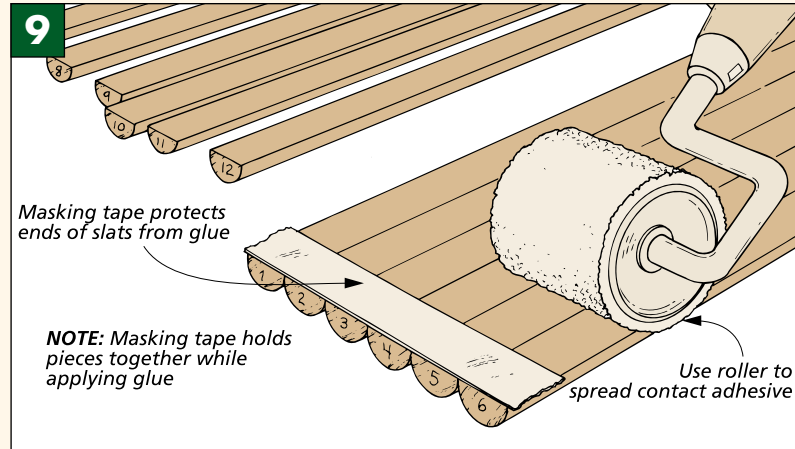

to one another. These guide boards keep the door pieces straight at the sides and parallel to each other.

I stretch out the canvas first (adhesive side up) so it's flat and tight. Just screw a guide board at one end to hold it in place, stretch it out, and secure the other end with a piece of scrap. Then using a framing square, install the other guide board square to the first one.

Now the lift rail and slats can be installed on the canvas. Just remember, when they make contact, you won't be able to move them. It's also a good idea to periodically check that the slats are running true, see Fig. 11.

After the slats are all in place, tap them with a mallet to remove any air gaps under the slats. Finally, to complete the door, trim off the excess canvas at the end. □

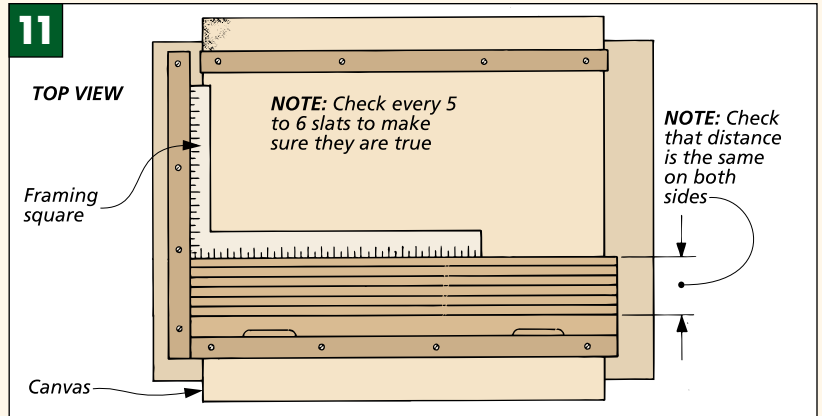
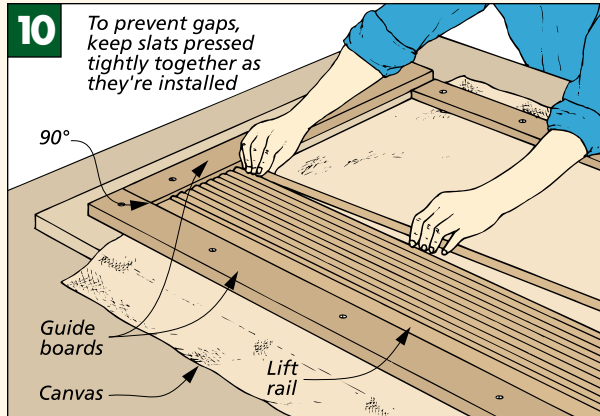

TROUBLESHOOTING TAMBOUR MOVEMENT

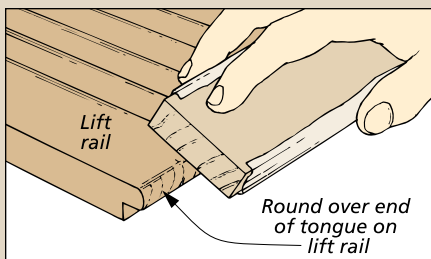

Lift rail. When a tambour won't slide freely, check the lift rail first. The sharp corners and edges can hang up in the groove. Use a sanding block to round over the end of the tongue.

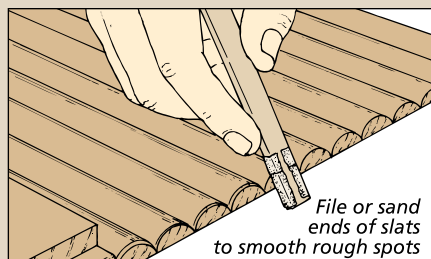

Slats. The slats can also hang up in the groove. Here again, round over the top and bottom ends. But because the groove is shallow, be sure to keep the radius small so it's not exposed.

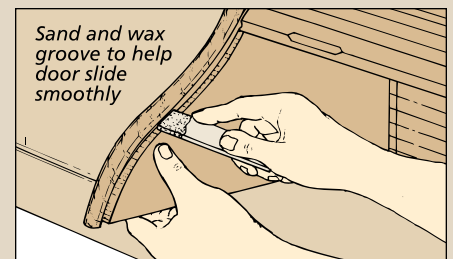

Sand & Wax. It's always a good idea to sand the groove lightly to remove any chatter marks left by the router. Then apply a coat of paste wax so the door will slide freely.

DESK ORGANIZER

This organizer is sized to fit the roll-top desk. But it's designed to look good from any side, so you can put it on a desk or even a counter top.

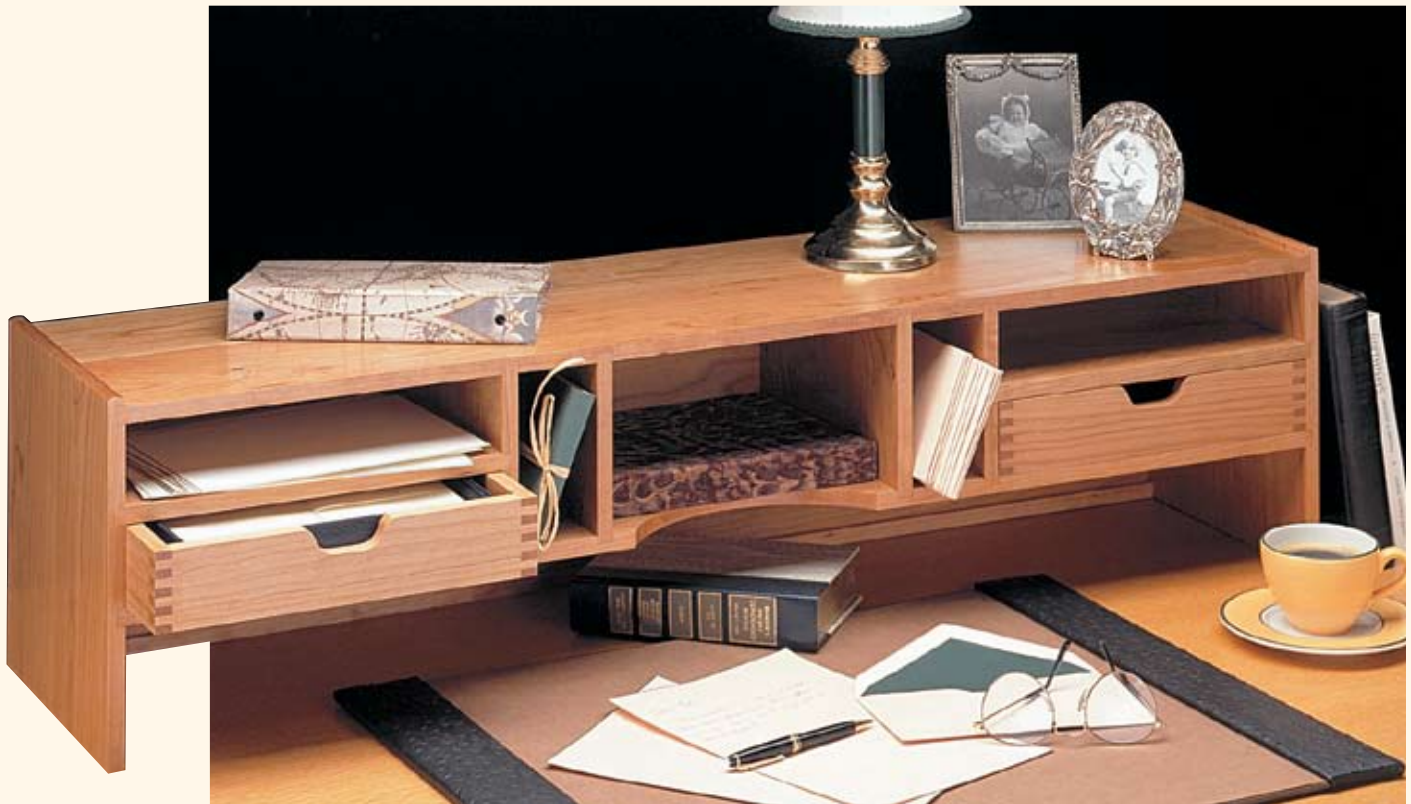

I don't know what it is about desks, but they seem to be built-in "clutter magnets." Letters, bills, junk mail, you name it — all are attracted to a desk like iron filings to a magnet.

That's what this desk organizer is all about. It has drawers and slots like those you'd find in an old post office desk, so things can be sorted neatly away. (At least in theory.)

Originally, I designed this organizer to slide inside the roll-top desk. But then I got to thinking, "Why hide it?" It would also look great (and be just as functional) sitting out on top of a regular desk or even on a counter.

But if you expose the back of the organizer, you have to take a couple things into consideration. Take the back panel, for instance. Since $\frac{1}{4}$ " plywood has only one good face, I had to veneer the "bad" side. Also, I wanted to hide the joinery at the back. This "stops" the dadoes and grooves, so they're not visible after the organizer is assembled.

TOP & SHELF

To build this desk organizer, I started with the top and shelf, see the drawing on the next page. Like most of the pieces in this organizer, they're made from $\frac{1}{2}$ "-thick stock that's been glued

into 10"-wide panels (rough size).

When the top (A) and shelf (B) panels are dry, they can be cut to the same length ($39\frac{1}{2}$ "). But their widths are different. The top ($9\frac{1}{2}$ ") is wider than the shelf (9") because it holds a back panel.

To hold the back, I cut a $\frac{1}{4}$ "-deep groove along the back edge of the top panel, see Figs. 1 and 1a. This groove is $\frac{1}{4}$ " wide to match the $\frac{1}{4}$ "-thick plywood back.

The top and shelf are connected by four dividers, see drawing next page. These fit in $\frac{1}{2}$ "-wide dadoes, see Figs. 1 and 1b. To make sure the dadoes line up, clamp the top and

shelf together and use a hand-held router and a straightedge guide.

But you don't want to rout all the way across both pieces. Otherwise when the organizer is assembled, the dados will be visible from the back. So instead, stop the dados when the router bit reaches the groove in the top panel. Then pare the remaining waste with a chisel, see Fig. 1c.

After routing the dados, all that's left is to cut an arc in the front edge of the shelf. To draw the arc, you'll need to locate the arc's centerpoint in a piece of scrap, see Fig. 2. Then simply cut it out and sand it smooth.

VERTICAL DIVIDERS

Next the dividers can be cut to join the top and shelf. There are four **vertical dividers (C)**, and they're all the same size, see drawing. (Their width is the same as the shelf — 9".)

The dividers are identical except for one thing. The two outside dividers also hold some horizontal dividers added later to create drawer openings. So I routed a 1/4"-deep dado centered on the height of each vertical divider, see Fig. 3.

When the dados are routed, the top, shelf, and vertical dividers can all be glued together, see drawing above. Go easy on the glue here; you don't want a lot of squeeze-out to clean up. And use a framing square to check that the assembly is square. If it's not, you'll have problems when adding the sides and horizontal dividers next.

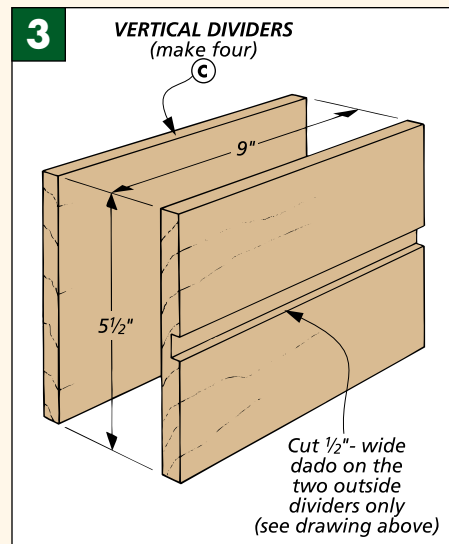
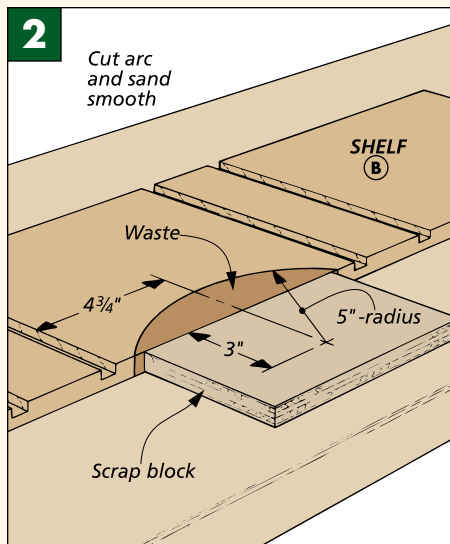
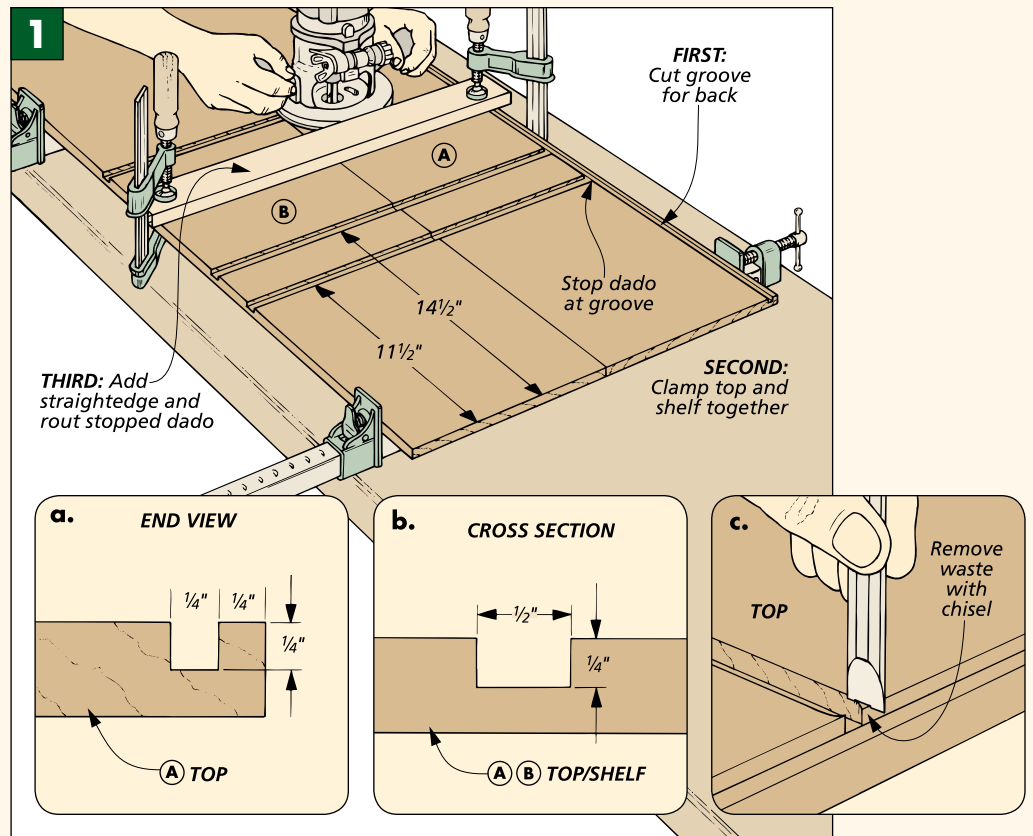
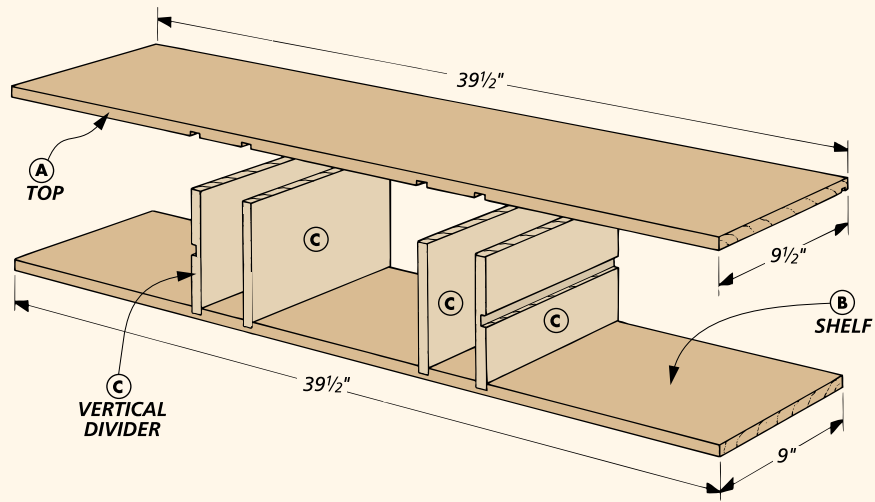

MATERIALS

ORGANIZER

A	Top (1)	1/2 x 9 1/2 - 39 1/2
B	Shelf (1)	1/2 x 9 - 39 1/2
C	Vert. Dividers (4)	1/2 x 9 - 5 1/2
D	Sides (2)	1/2 x 9 1/2 - 10
E	Horiz. Dividers (2)	1/2 x 9 - 11 3/4
F	Back Molding (1)	1/2 x 3/4 - 39 1/2
G	Back (1)*	1/4 ply. - 9 1/4 x 39 1/2
H	Filler Strips (2)	1/4 x 1/4 - 8 1/2

DRAWER

I	Fronts/Backs (4)	1/2 x 2 1/4 - 11 3/16
J	Sides (4)	1/2 x 2 1/4 - 9
K	Bottoms (2)	1/4 ply. - 8 1/2 x 10 11/16

*Also Needed: 10" x 40" sheet of cherry veneer

When the glue in the organizer assembly is dry, the next step is to add the sides. These panels sandwich the ends of the assembly and also hold two horizontal dividers.



▲ To rout a bullnose on thin stock, you need to position the router fence flush with the bearing.

SIDES & DIVIDERS

The **sides (D)** join the ends of the top and shelf, see Fig. 4. Begin by ripping two 1/2"-thick panels to match the width of the top (9 1/2"). The lengths of the side panels will determine the height of the organizer.

Note: To fit inside the roll-top desk, the sides should be just slightly shorter than the desk's tambour opening. (I cut my sides 10" tall.)

Next, rout three 1/4"-deep dadoes in each side, see Figs. 4 and 4a. The first holds the top panel and is located 1/4" down from the top edge. The other two align with the shelf and the dado cut on the vertical divider.

Now to hold the back (and filler strips) added later, each side also needs a 1/2"-wide rabbet, see Fig. 4b. Like the dadoes in the top panel, this rabbet is stopped.

Finally, to soften the top end of the side panels, I used a 1/2" roundover

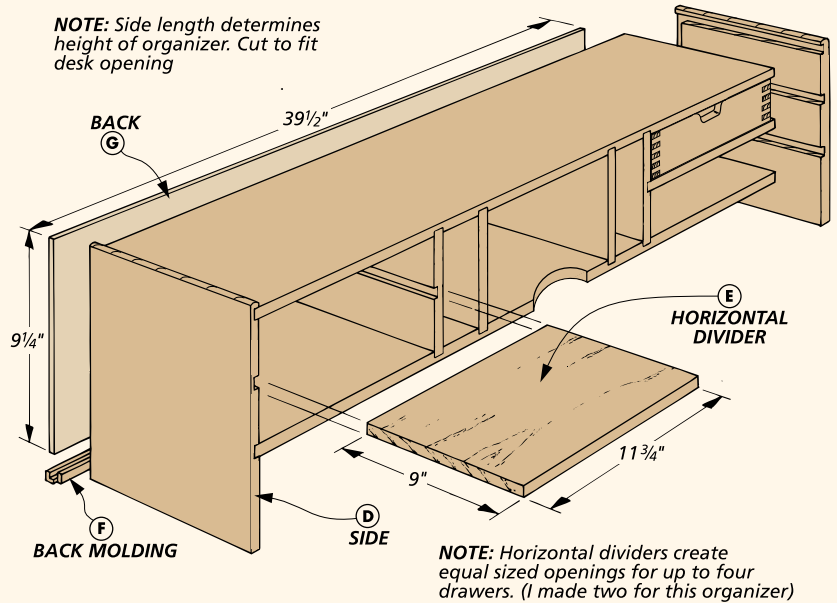

bit in the router table to rout a bullnose profile, see the margin at left.

DIVIDERS. With the side panels complete, it's time to add the **horizontal dividers (E)**. These pieces are simply 9"-wide panels that are cut to fit between the dadoes in the sides and the vertical dividers. When they've been cut to size, the horizontal dividers and the side panels can be glued

and clamped to the ends of the organizer assembly.

BACK

Now it's time to add the back. Here, I used a piece of 1/4"-thick plywood. The problem is the back isn't very stiff, especially along the bottom. So before adding the plywood panel, I made a piece of molding to add support.

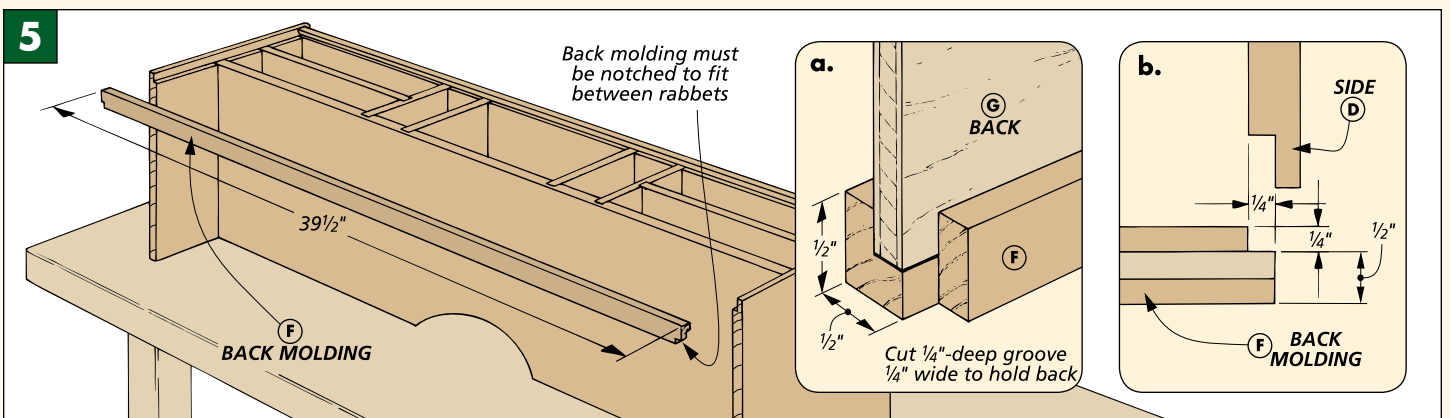
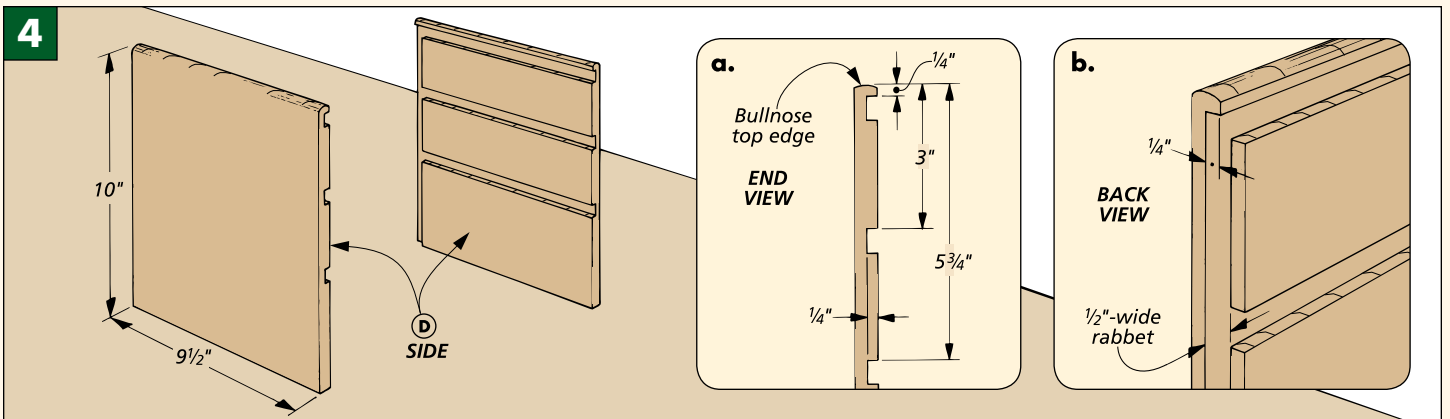

MOLDING. This back molding (F) is cut to fit between the rabbets in the sides, see Fig. 5. But this piece is $\frac{3}{4}$ " wide, while the rabbets are only $\frac{1}{2}$ " wide, so I had to notch the front corners to make it fit, see Fig. 5b.

Next I cut a $\frac{1}{4}$ "-deep groove in the molding to hold the $\frac{1}{4}$ "-thick plywood back, see Fig. 5a.

BACK. Now that the molding is complete, you can work on the back (G), see drawing at right. Since both sides of the plywood will be visible, I glued veneer to the rough side before cutting it to size. Then I glued the back and the molding to the organizer.

FILLER STRIPS. There's still one more step to complete the back. To hold the back at the sides, I added filler strips (H), see drawing. These $\frac{1}{4}$ " x $\frac{1}{4}$ " strips are cut to fit between the top panel and back molding and are simply glued in the rabbet cut on the sides, see drawing above right.

DRAWERS

With the case complete, I built two drawers to fit the organizer. Cut the drawer fronts/back (I), and sides

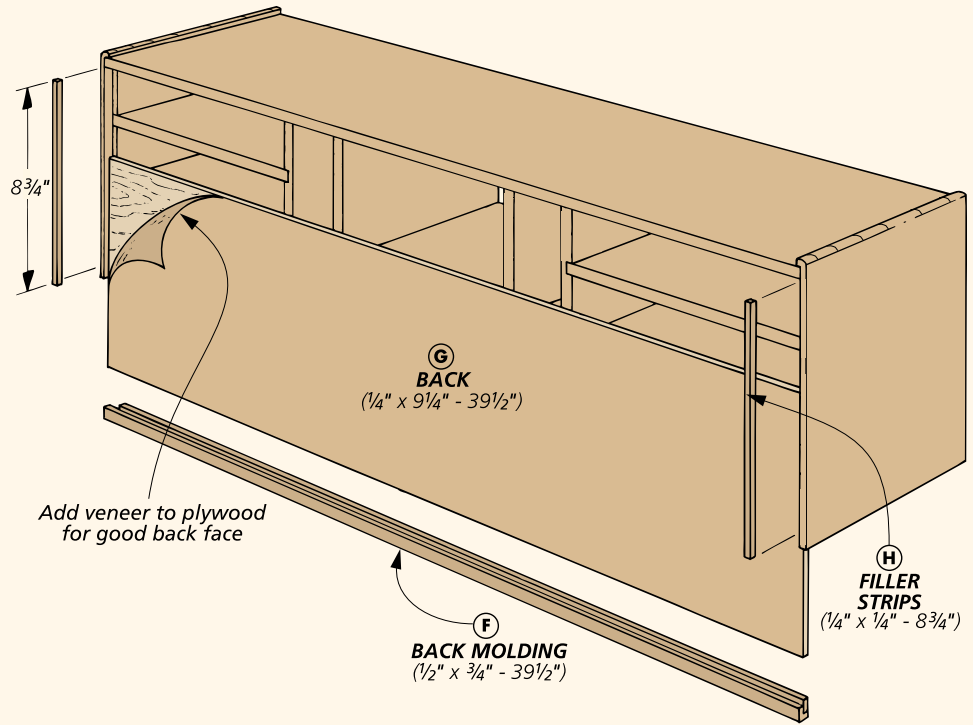

(J) to size, see Fig. 6. (Allow for a $\frac{1}{32}$ " gap at each side. But the height of each drawer should match its opening.)

The drawer is joined with $\frac{1}{4}$ " box joints, and the $\frac{1}{4}$ " plywood bottom (K) is held in a groove that's cut in each piece, see Figs. 6a and 6b.

Now before assembling the drawers, I cut an opening for a handle on each front piece, see Fig. 7.

Finally, assemble the drawers and fill the groove openings, see photo. Then trim the top and bottom edges for a $\frac{1}{32}$ " gap above the drawer. □

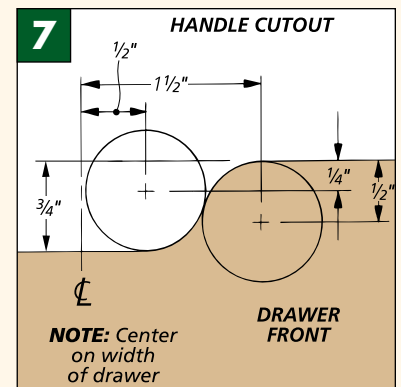
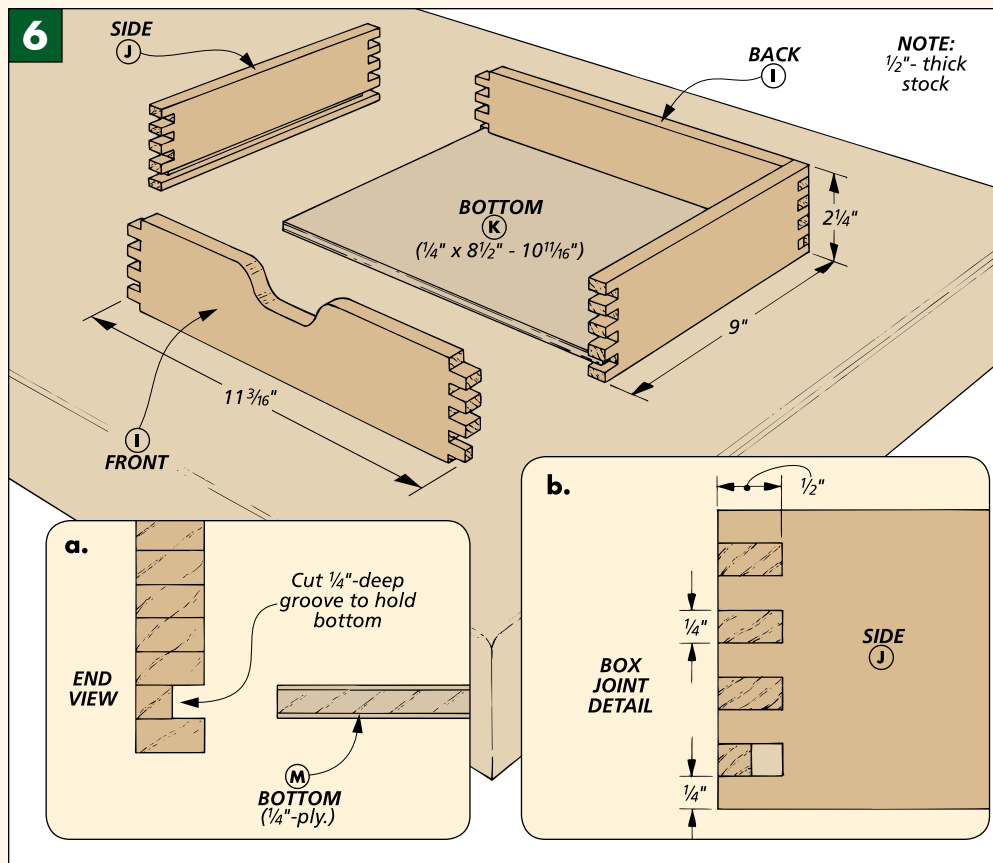

▲ After each drawer is assembled, the grooves for the drawer bottom will be exposed on the sides. Small hardwood plugs will hide them.