



# THANK YOU!

---

You have successfully downloaded your *Woodsmith* project plan.

▶ [Go to Page 1](#)

## **Get More from Your Table Saw...at PlansNOW.com**

---



### **Build our 10 BEST Table Saw Jigs!**

What really makes a table saw so versatile are the jigs and accessories that improve your saw's overall performance.

▶ [Download Today at PlansNOW.com...\\$4.95](#)

## **Woodsmith Shop TV Show Special...Save 10%**

---



### **Use Coupon Code *TVSHOW* at PlansNOW.com**

Visit PlansNOW.com today and save 10% on more than 200 woodworking plans and how-to technique articles.

▶ [Go to PlansNOW.com Now](#)

## **You Can Build It...at PlansNOW.com**

---



### **Workbenches**

Good woodworking starts with a solid workbench.



### **Shop Jigs & Techniques**

Get the most from your tools with easy-to-build shop jigs.



### **Cabinets & Shelves**

Build stunning furniture that's both functional and beautiful.



### **Home Improvement**

Save hundreds of dollars in remodeling when you DIY.



Woodsmith **PLANS**

# FAST & EASY SANDPAPER SHARPENING



# SANDPAPER SHARPENING

*Once you try sharpening with sandpaper, you might just give up on other methods. It's quick, inexpensive, and the results can't be beat.*



When it comes to putting a sharp edge on a chisel or plane blade, woodworkers have a lot of options. But there's one tried-and-true sharpening technique I like that's often overlooked. This method involves using sandpaper fixed to a piece of glass as your honing "stone." It gives you a sharp edge in short order without a big investment.

**WHY I LIKE IT.** Before we get into the

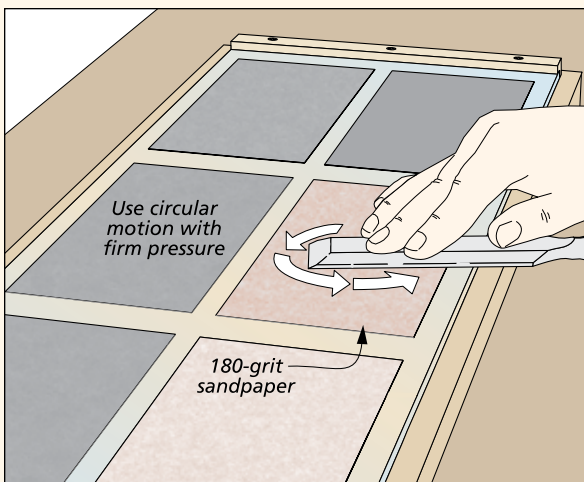

▲ **Start with the Back.** A sharp edge requires both a flat, polished back and a polished bevel. So I start sharpening by working on the back of the chisel blade.

nitty-gritty, so to speak, let me tell you why sharpening with sandpaper and glass is a favorite of mine. First, the plate glass gives you a large, flat, wide-open surface to work on. So unlike working on a small stone, you're not limited to short back and forth strokes, and the work goes much faster.

A second plus is the wide range of sandpaper grits available for sharpening. Standard aluminum-oxide paper is perfect for the coarse work at the early stages. Then wet-or-dry silicon-carbide paper (up to 2000-grit) takes over to put a fine polish on the edge.

**THE SETUP.** Now, let's look at the setup I use, shown at the bottom of page 2. At the heart is a piece of ¼"-thick plate glass. This can be whatever size is handy, but mine is 10" wide by 36" long. This gives me room for two half-sheets of sandpaper across the width and a variety of grits along the length.

A large piece of glass lying around the shop could easily get broken. So I fastened the glass to a plywood base. This makes it much easier and safer to use, and to store.

**SANDPAPER.** As I mentioned, I use two types of sandpaper. A couple strips of self-adhesive, aluminum-oxide paper (80- and 180-grit) get me started. It comes in rolls and has a nice, heavy backing. The remaining space is filled with four different grits of wet-or-dry silicon-carbide sandpaper — 320-, 800-, 1500-, and 2000-grit. This gives you a steady progression. A light coat of spray adhesive holds this sandpaper to the glass.

**A RAZOR-SHARP EDGE.** With the sandpaper in place, you're ready to go. Set the sharpening platform on the benchtop, clamp it between the dogs, and grab a chisel or plane iron that needs attention.

**FIRST, THE BACK.** Before honing the bevel, you want to make sure the back is flat and lightly polished (left drawing). This is done using a circular motion from the side of the platform. At this point, I rely on 180-grit to do the job. All I'm looking for is an even scratch pattern.

**HONING GUIDE.** Now, to work on the bevel, I clamp the tool in a honing guide. This simple helper holds the blade at the exact bevel angle

I'm after. I find it makes the work go a lot faster and the results are more consistent. The drawing at right shows how to use the guide notches I cut into the platform to set the bevel angle. This gives me an accurate setup in short order.

**THE BEVEL.** The grit you start with depends on the condition of the edge. If it's badly nicked or out of square (upper photo in the margin), I'll start at the coarsest grit. Think of this as the grinding stage. You can save time and effort later by getting the hard work done here. But if the bevel only needs "touching up," you can start honing at a finer grit.



▲ Long, back-and-forth strokes with firm pressure on the tip will quickly flatten the bevel and remove nicks.

There's no great secret to the technique. Just lay the guide and tool on the surface of the sandpaper and take long, back-and-forth strokes (lower left photo). To keep the work going quickly, concentrate the pressure near the tip of the tool. I also like to take advantage of the entire honing surface by moving the tool around. Finally, it's a good idea to keep the sandpaper clean by brushing or blowing it off regularly.

**MOVE ON.** When you see a perfectly flat bevel and a straight, nick-free edge, you're ready to move on. Simply step up to the next grit and repeat the same process. You've done the hard work, and now you're just making finer scratches and a sharper edge.

**WET-OR-DRY.** When you get to the wet-or-dry sandpaper, one thing changes. This type of sandpaper cuts more efficiently when lubricated with water. So I like to have a spray bottle handy to keep the sandpaper wet and cutting fast (main photo on page 1).

At this point, the work goes quickly. A minute or so at each grit does the job. As the scratches get finer, you'll see the bevel shine brighter. At 800-grit you'll have a dull polish and a

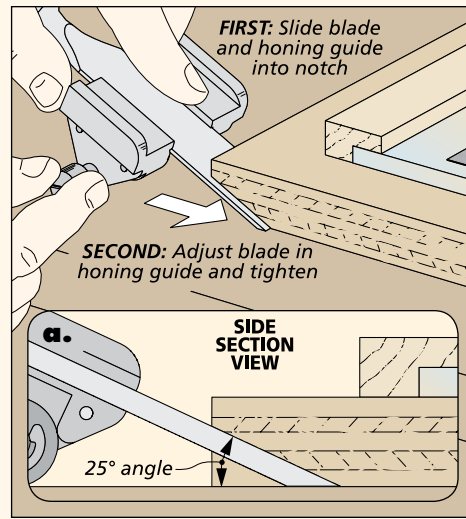

▲ No Guesswork. Guide notches in the corners of the sharpening platform make setting the honing angle painless and accurate.

keen edge. For a lot of work, this is probably good enough. But for a mirror-like bevel with a "hair-splitting" edge, keep going to 2000-grit.

When I've reached my stopping point, I take the tool out of the honing guide for one final step. I finish polishing the back of the chisel to match the bevel. This ensures the sharpest edge possible.

**HOW LONG?** My sharpening goal is to get the job done as fast as possible. And on that score, this method is a winner. If you make it a point to replace the sandpaper when it starts to wear, you're talking a few minutes from start to finish. That's not bad in my book. **W**



▲ This edge is badly nicked and the bevel is too shallow.



▲ But a short while later, it looks like a new chisel.

## ALL-IN-ONE SHARPENING PLATFORM

Here's how to put a sharpening platform together. First, ask a glass supplier to cut you a piece 1/4"-thick plate glass and soften the edges. Next, use rabbeted cleats to fasten the glass to a 3/4" plywood base,

as shown in the drawing below. This makes the glass easier to manage. A couple of angled notches in the corners of the base act as set-up guides for sharpening. Finally, a hang hole in the end makes storage easy.

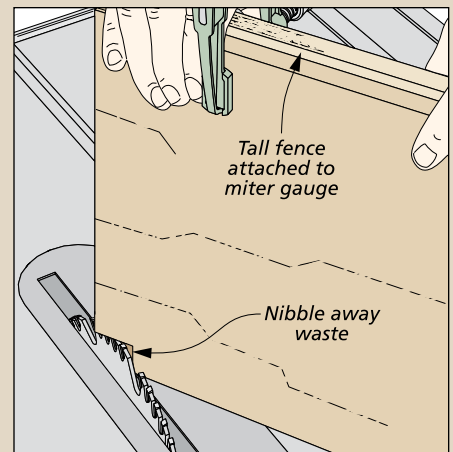
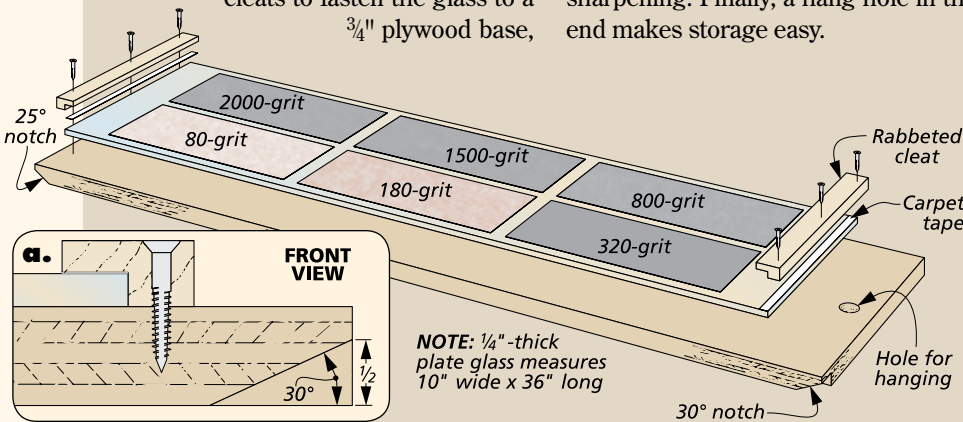

▲ Nibble Away Waste. A tall fence attached to the miter gauge allows you to cut the "guide" notches in the plywood base. A hand saw could be used to do the job.