



Woodsmith **PLANS**

7 TIPS FOR WORKING WITH PLYWOOD



WORKING WITH PLYWOOD

Plywood has its challenges. It's heavy and cumbersome to work with. And the edges and veneer are prone to being damaged. But with a few of our shop secrets, you can meet each and every challenge.

1. Easy Loading

The first step in dealing with plywood is just getting it into your vehicle — and then back out once you get it to your shop.

I came up with a way to do this with an old appliance cart (see photo). With the cart resting on the tailgate (with the wheels up), I lift one end of the sheet onto the wheels. Then I pick up the other end off the ground and “roll” the sheet into the bed of the pickup. To get the sheet out, simply reverse the process.



2. Move it Along

Once you get the sheet of plywood home and out of the truck, you'll need to move it into the shop. To avoid having to carry it around the shop, I made a “skateboard” from a piece of scrap 2x6 and a set of casters, like you see in the photo at left.

To ensure the plywood doesn't slip off the top as you're moving the sheet around, there's a shallow groove cut down the center of the top, as illustrated in the drawing below. And to make it easy to steer, the caster at the front swivels.

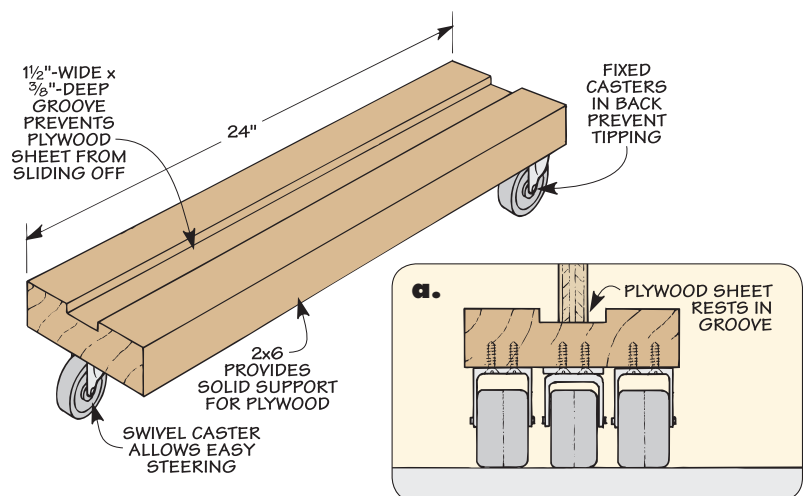

3. Quick & Easy Tote

Rolling a sheet of plywood around is quite easy. But sooner or later you'll need to carry a plywood sheet to get it right where you

need it. When that's the case, I use the "handy" tote shown in the drawing and the photo.

The tote is designed to hook under the bottom edge of the plywood. A round handle that fits into the sides of the tote is easier on your hand than the sharp edges of the plywood. And the extended sides on the tote make it possible to pick up a heavy sheet by lifting with your legs — rather than your back.

Note: When using the tote, be sure to center the plywood sheet on the support for better balance. And to prevent the plywood sheet from tipping, place your other hand at the top of the sheet to steady it.

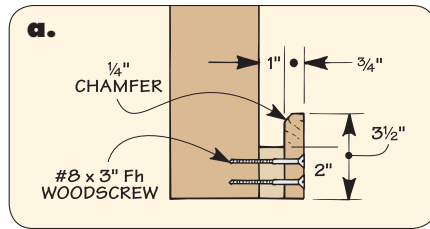
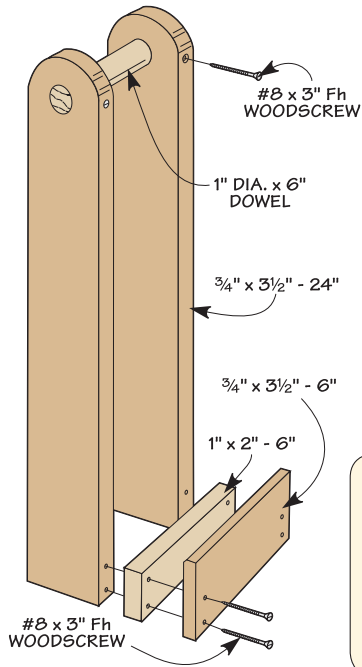

4. Up Against the Wall

I like to cut up the plywood for my project right away. But there are times I can't always do that. So I came up with a way to store plywood sheets nice and flat until I can.

All you need to do this is some free wall space and the storage bracket shown in the photo and illustrated in the drawing below.

The wall bracket consists of two parts: a hinged bracket attached to the wall that holds the plywood in place, and an index bar that adjusts

the opening of the bracket to allow for varying amounts of sheet goods.

The hinged bracket is nothing more than two 2x4s joined together at one end with a 3" butt hinge. You'll also notice that there's a 1/2"-dia. dowel glued into the top of each 2x4.

These dowels fit in holes drilled into the index bar so you can adjust the front bracket piece. The plywood is held against the wall with another 1/2"-dia. dowel (8" long) that's glued into the bottom of the front bracket.

I ripped the index bar to width from a short length of 2x4. Once you have it cut to size, the holes can be drilled. Then, to soften the sharp corners and allow the index bar to clear the wall, I sanded a radius at each end of the bar.

To use the storage bracket, select a hole in the index bar that takes the most slack out of the front bracket. When you want to sort through the stack, just set the index bar so the dowels are in the outside holes.

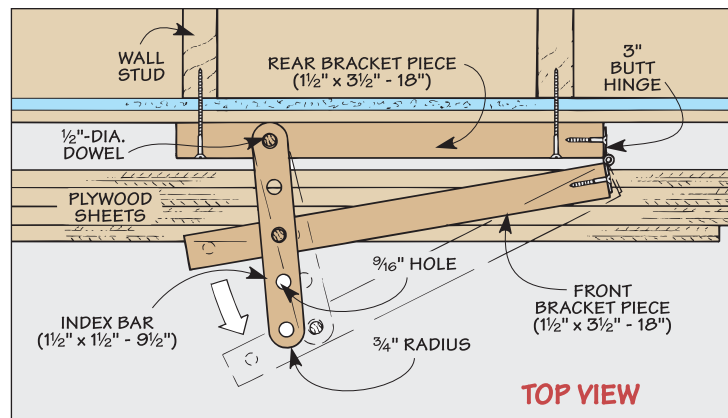

5. Build a 2-in-1 Cutting Guide

One of the biggest challenges when working with plywood is cutting a large sheet down into pieces that are a little easier to handle. Even with help, it's a hassle to cut plywood on a table saw. To avoid this, I use my circular saw and a cutting guide like you see in the photo at right.

The cutting guide not only solves the problem of making a straight cut, but it makes it easy to position the saw so you know exactly where the cut is going to be.

AN ACCURATE REFERENCE EDGE. The way this works is simple. The edge of the guide acts as a reference that indicates the path of the blade (or router bit, but more about that in a minute). Ensuring an accurate cut is just a matter of aligning one of the edges of the guide with the layout line on the workpiece.

BUILD THE GUIDE. There's nothing too complicated about making the cutting guide. Start out with an extra-wide base made from $\frac{1}{4}$ " hardboard (see drawing below).

The next step is to glue and screw a plywood fence to the base. Since the fence is going to establish the reference edge, it's important to attach it so it's perfectly straight.



Once the fence is in place, you can create the reference edge by trimming off the waste with a circular saw. The nice thing about the extra width on the base is that by using a hand-held router and a straight bit, you can create a second reference edge on the other side of the guide.

When I'm using my circular saw, I like to use a steel saw blade designed specifically for plywood, like the one shown in the margin. But when using my table saw or router, I use a different blade or bit. To learn a little more about these, check out the box below.

THE CUTTING EDGE
Although the guide will make a straight cut with either a circular saw or a hand-held router, it won't guarantee you a chipout-free cut.



▲ **Circular Saw Blade.** To help reduce chipout, the inexpensive, steel saw blade shown above has tiny, razor sharp teeth that remove small amounts of material.

END VIEWS

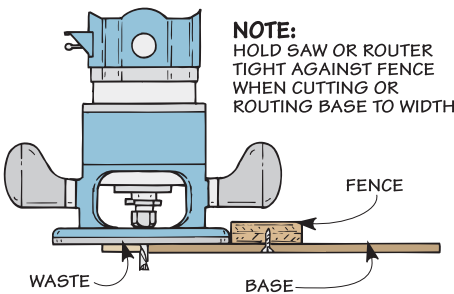
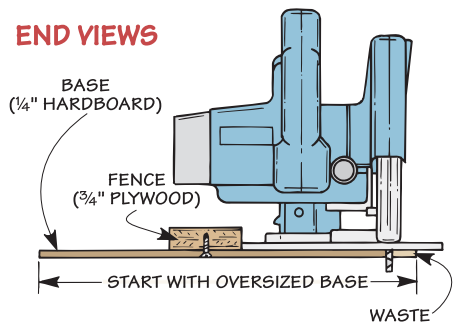

THE CUTTING EDGE

▶ **Compression Bit.** Combining up and down shearing flutes eliminates chipout on both faces of a sheet of plywood by "compressing" the cut to the center of the sheet. They're sold with either single or double flutes. The double shown at left is made by Freud (#77-206).



▶ **Plywood Blade.** Designed to produce a superior cut on both the top and bottom of laminates and melamine, this triple chip grind blade with a negative hook angle (Freud #LU97R) works equally well when cutting plywood.

6. Breaking Down Big Sheets

Before making any cuts, you'll need to lay out the pieces on the plywood. It's a good idea to allow a minimum of $\frac{1}{4}$ " extra all the way around to provide enough material to make the final clean-up passes later.

Still, cutting plywood to rough size doesn't mean you want a ragged cut. The goal is to end up with clean, straight edges that can ride against the rip fence (or be placed against a miter gauge or an auxiliary sled).

FOAM SUPPORT. To accomplish this, I use the cutting guide and saw blade I mentioned earlier. In addition to

the guide, you'll also need a way to support the plywood during the cut. The best way I've found to do this is to lay the plywood on a sheet of foam insulation, as in the photo at right. (I got mine at a local home center.)

KEEP THE GOOD SIDE DOWN. One thing to be aware of is that the blade on a circular saw cuts on the upstroke. This means the top surface of the plywood is likely to splinter. So even

with a specialty blade that reduces chipout, it's best to place the plywood with its good face down on the foam.



7. Get a Perfect Finish Cut

One of the reasons for allowing a little extra material is to remove the "factory edge." You can usually count on this edge to be straight and true. But it's often dented or nicked. So it's best to trim it off.

To do this, you'll need to adjust the rip fence to make an extra-wide cut, as illustrated in Figure 1. Then, after readjusting the fence, run the "just-cut" edge against it and rip the piece to final width.

One problem area is crosscutting a wide piece. Trying to do this often results in the bar of the miter gauge not being fully supported, resulting in a less than accurate cut.

SLIDING PLATFORM. The solution is a large, sliding platform that provides extra support for the workpiece, like you see in Figure 2.

The platform is just a plywood base that carries the workpiece through the blade. The base is guided by a hardwood runner that slides in the miter slot. As you make a cut, a fence keeps the workpiece square to the blade.

FLUSH TRIM IT. Sometimes a workpiece is too wide even for the sliding platform. That's when a hand-held router comes in handy.

With the cutting guide and a compression bit (see previous page), you can cut a clean, straight edge without any chipout (Figure 3).

