



Woodsmith **PLANS**

ROUTER TABLE DOVETAIL KEY JIG



ROUTER TABLE DOVETAIL KEY JIG

Dovetail keys are a great way to strengthen a miter joint. This jig takes the hassle out of cutting the slots for the keys.



Mitering the corners of a project is a good way to give it a nice, clean look. But a glued up mitered joint isn't all that strong. A great way to provide extra

strength, along with good looks, is to add dovetail-shaped hardwood keys across the corners.

The challenge comes in accurately positioning and cutting the

slots for the dovetail keys. The solution is the jig you see above. It securely holds the project at the correct angle while you make the cuts on the router table.

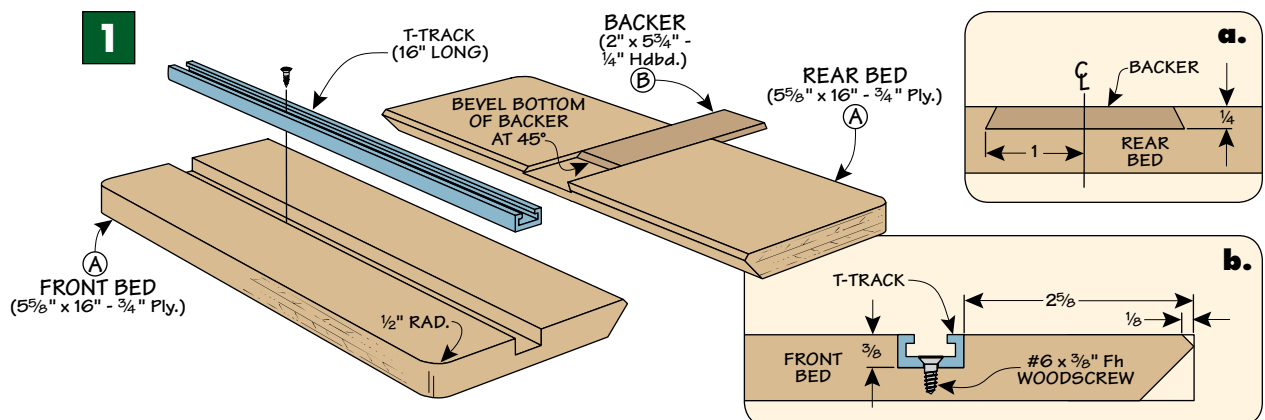

THE JIG. The jig is just a pair of angled bed assemblies that support both sides of the project. They're attached to a hardboard base. A runner attached to the base guides the jig in the miter slot of your router table. Note: If your table doesn't have a slot, you can leave the runner off and guide the jig using your router table fence.

A piece of T-track that rests in a groove in the front bed is used to lock in a pair of stops that keep the workpiece in position during the cut. In the rear bed, I cut a dovetail-shaped dado to accept a replaceable backer that helps prevent tearout (Figure 1a). You can read more about this in the Shop Short Cut on page 5.

Finally, I rounded the top outside corners and shaped the inside edge of each bed, as in Figures 1 and 1b.

JIG ASSEMBLY. Once the bed supports are completed, you can glue and screw them to the beds using braces, as illustrated in Figure 2. Like the beds, the outside corners of the supports are rounded.

The two beds are attached to the base to create a cradle assembly. I sized the base so that when the beds were glued in place, it created a small dust relief (Figure 2b).

Before moving on and adding the runner, there's one thing to do

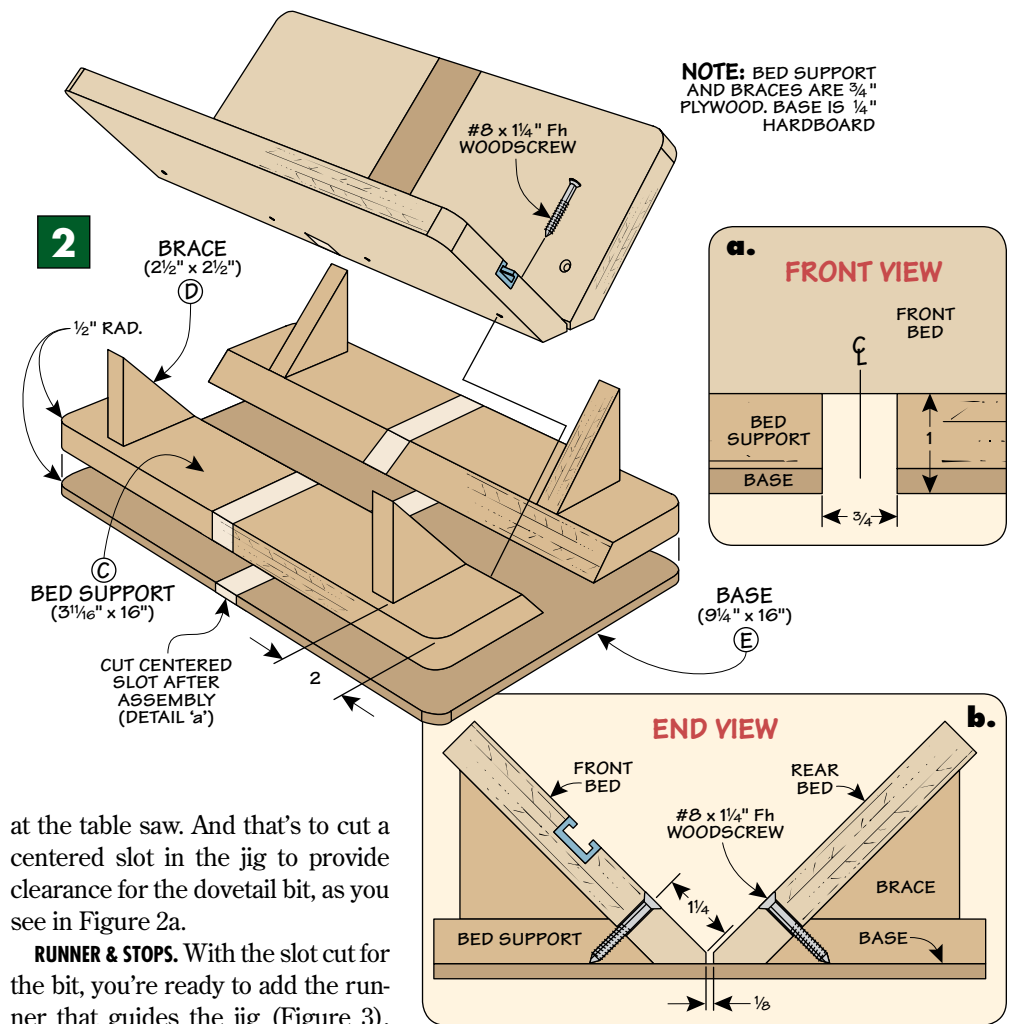

NOTE: BED SUPPORT AND BRACES ARE 3/4" PLYWOOD. BASE IS 1/4" HARDBOARD

at the table saw. And that's to cut a centered slot in the jig to provide clearance for the dovetail bit, as you see in Figure 2a.

RUNNER & STOPS. With the slot cut for the bit, you're ready to add the runner that guides the jig (Figure 3). It's just a strip of hardwood cut to fit the miter slot of your router table.

You'll need to locate the runner to center the slot over the bit and install it square to the front edge (Figures 3 and 3b). Finally, I added the stops.

Each is simply two small pieces of plywood glued and screwed together at a right angle. They're locked in place using a flange bolt, washer, and knob, as in Figure 3a.

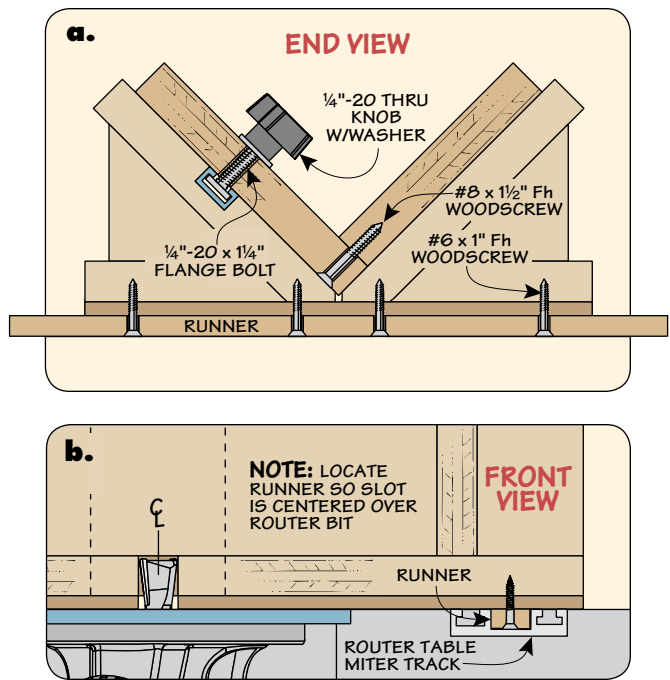
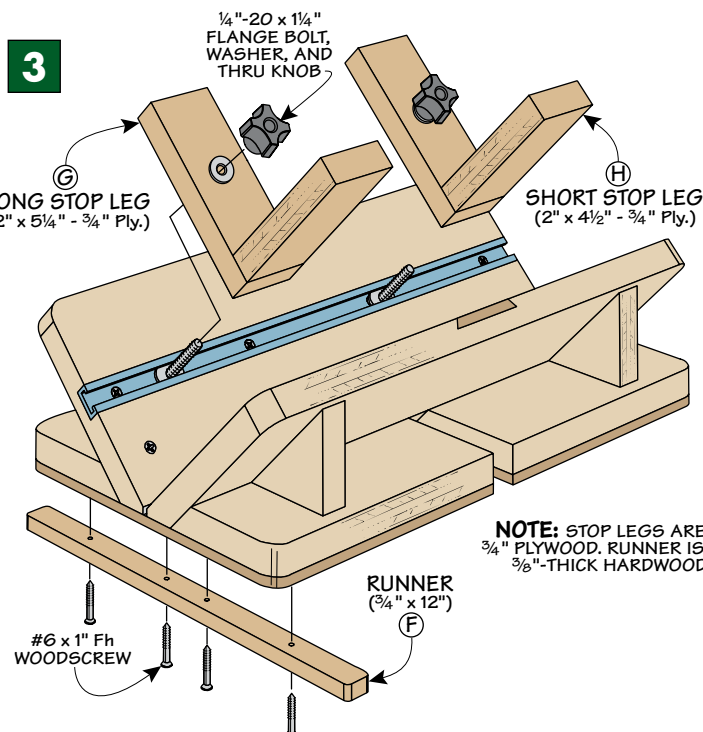

Using the Jig

Once you have the jig completed, cutting the slots for the keys, like the ones you see in the photo at right, is a snap. It's a simple step-by-step task that only takes a few minutes. To complete the joint, you'll make the dovetail-shaped keys and glue them in place. And finally, trim and sand them flush.

ROUTING THE SLOTS

As I mentioned earlier, the jig makes routing the slots for the keys easy. The first step in doing this is setting the depth of cut.

SETTING THE DEPTH. I've found that the easiest way to do this is to install the dovetail bit and position the jig over it. In Figure 1 you can see a layout line drawn across one corner of the project. This line represents the

desired depth of the key slot and provides an easy reference for adjusting the height of the bit to match.

POSITIONING THE PROJECT. That takes care of the depth of cut, so you can move on to the next step — positioning the project in the jig. To do this, you need to know exactly where the bit will cut. As illustrated in Figure 2, I marked a layout line along the top edge of the backer to indicate the centerline of the bit.

Now that you know where the centerline is, you're ready to position the project using the stops. They'll keep it from shifting side to side. To do this, make additional layout lines on the sides of the project.

Each layout line indicates the center of a slot, and the number and spacing of the lines will depend on



Cut Slots. The jig positions the project securely to cut a dovetail-shaped slot for a key.

the project. The main goal is to mark the layout lines on one side so they extend above the top edge of the jig (Figure 3). This makes it easy to position the project to align with the centerline on the backer. Then, simply slide the stops against the sides of the project to lock it in place.

ROUTING A SLOT. At this point, creating a slot is just a matter of turning on the router and making a single pass. To cut a slot on the other three corners, just rotate the project and make an identical pass.

If your slot layout is symmetrical along the corner of the project, you won't always need to reposition the stops to cut a slot. As you can see in the example in Figure 4, flipping the project takes care of locating the slot identically for the next four passes. If you have more slots to cut in a different location, simply readjust the stops and repeat the process.

CREATING THE KEYS

Cutting the slots is just half the job. The final task is to add the dovetail-shaped keys. The nice thing is that you'll stay right at the router table and use the same bit.

SAFETY FIRST. Because the keys are small, it's best to start with a long, extra-wide blank. This way, you can work safely and more accurately. The goal is to rout dovetails along the edges of the blank that fit snug in the slots, as in Figure 5.

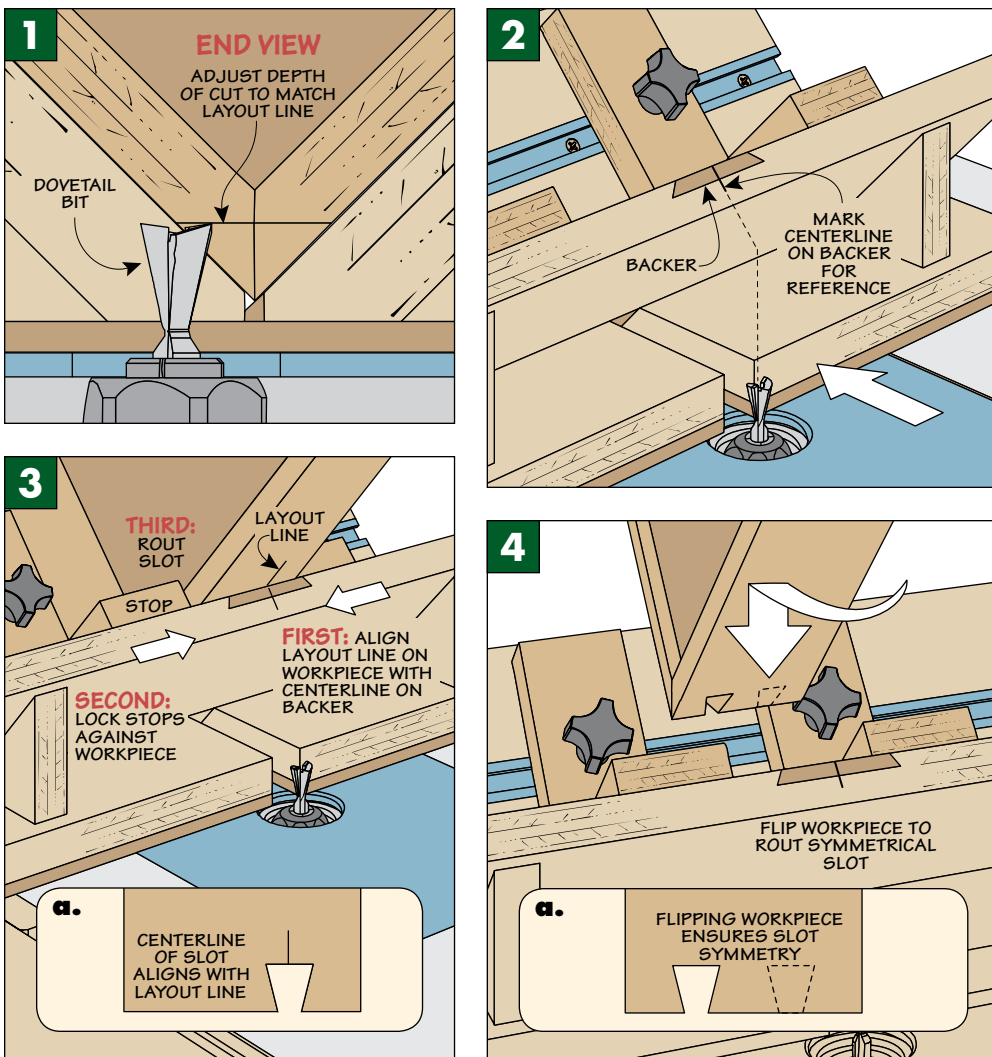

SIZING THE KEY. To start, adjust the height of the bit to cut slightly deeper than the depth of the slot. Then, sneak up on the size of the key by making a series of passes. The extra width of the blank allows you to rout a key along both edges of the blank. Just be sure to check the fit frequently, as in Figure 5b.

RIP THE KEY STRIPS. When you have a good fit, you're ready to rip the keys from the edges of the blank (Figure 6). I positioned my rip fence to cut the strip free right along the shoulder line, as you see in Figure 6a.

GLUE IN THE KEYS. After cutting individual keys free from the strips, double check the fit of each key before you glue any of them in place. You may find you have to sand one side of each key lightly to get a perfect fit. To avoid installing a key in the wrong slot, I found it easiest to fit and glue each key in one at a time, as shown in Figure 7.

FINAL DETAILS. Give the glue time to dry, and then use a hand saw to remove most of the waste from each key. Just make sure not to mar the



Check the Fit & Glue. Check the fit of the keys as you make them, and then glue them in place.

Trim & Sand Flush. Once the glue dries, trim off the waste and sand the keys flush.

sides of the project. I like to use a flush-cut saw, like the one shown in Figure 8, because it's the simplest way to avoid marring the sides as you make the cut.

All that's left is sanding any remaining waste flush with the sides. To ensure a smooth, flat surface, I like

to sand with the grain and back my sandpaper with a hardwood block, as in Figure 9.

Dovetail keys are a great way to strengthen a mitered joint and give a project an appealing decorative touch. The jig makes the whole process quick and easy.

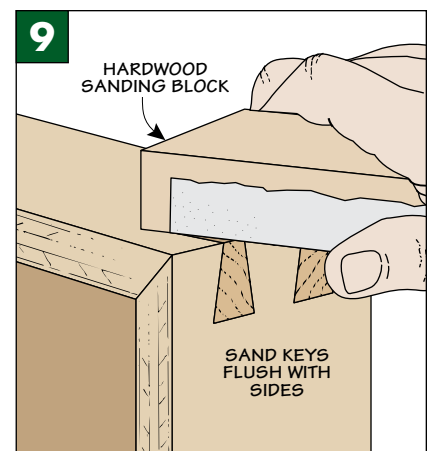
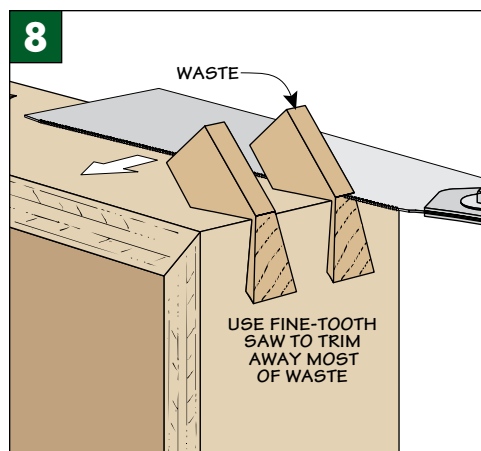
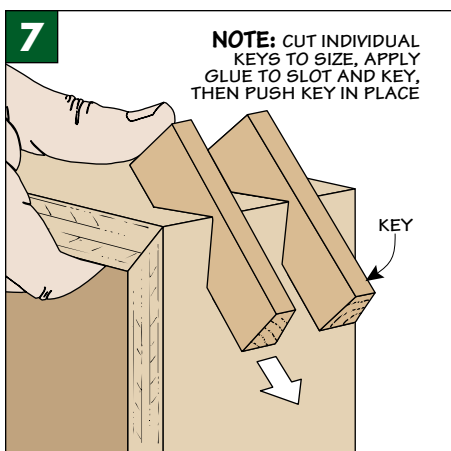
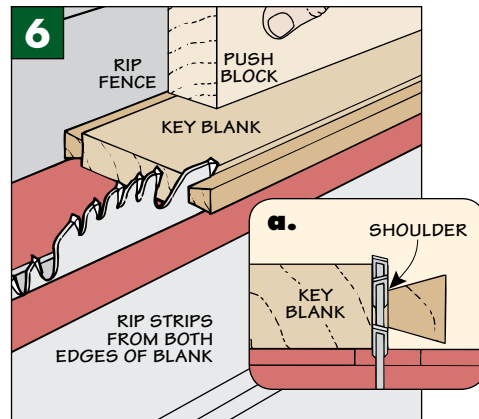
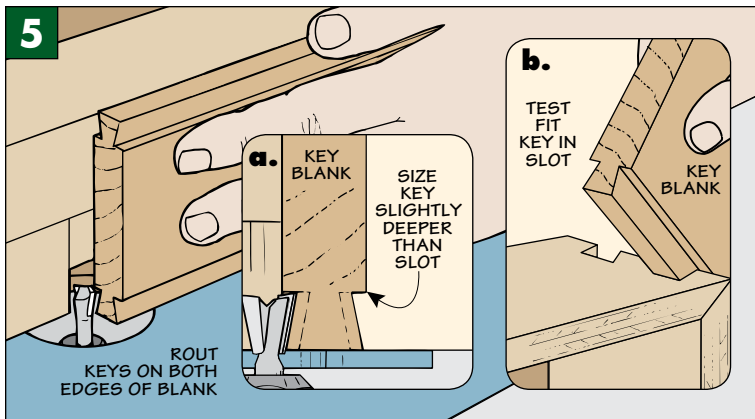

SHOP SHORT CUT

Dovetail Key Backer

When using the router table dovetail key jig to rout slots, it's important to support the back of the workpiece as the bit exits. This way, you'll reduce tearout and leave a nice, clean edge to highlight the dovetail keys.

The dovetail key jig incorporates a replaceable hardboard backer just for this purpose. It slips into a dovetailed recess, as you can see in the drawing at right.

I cut the recess at the router table using a dovetail bit. The depth of cut should equal the thickness of the hardboard you'll use for the backer (detail 'a'). After routing the two sides of the recess, clean out the waste with multiple passes.

Making the insert is an easy task at the table saw. I made several to have on hand by ripping long stock with the blade tilted (detail 'b').

