

# How to Build Your Very Own Weaving Loom – PLANS

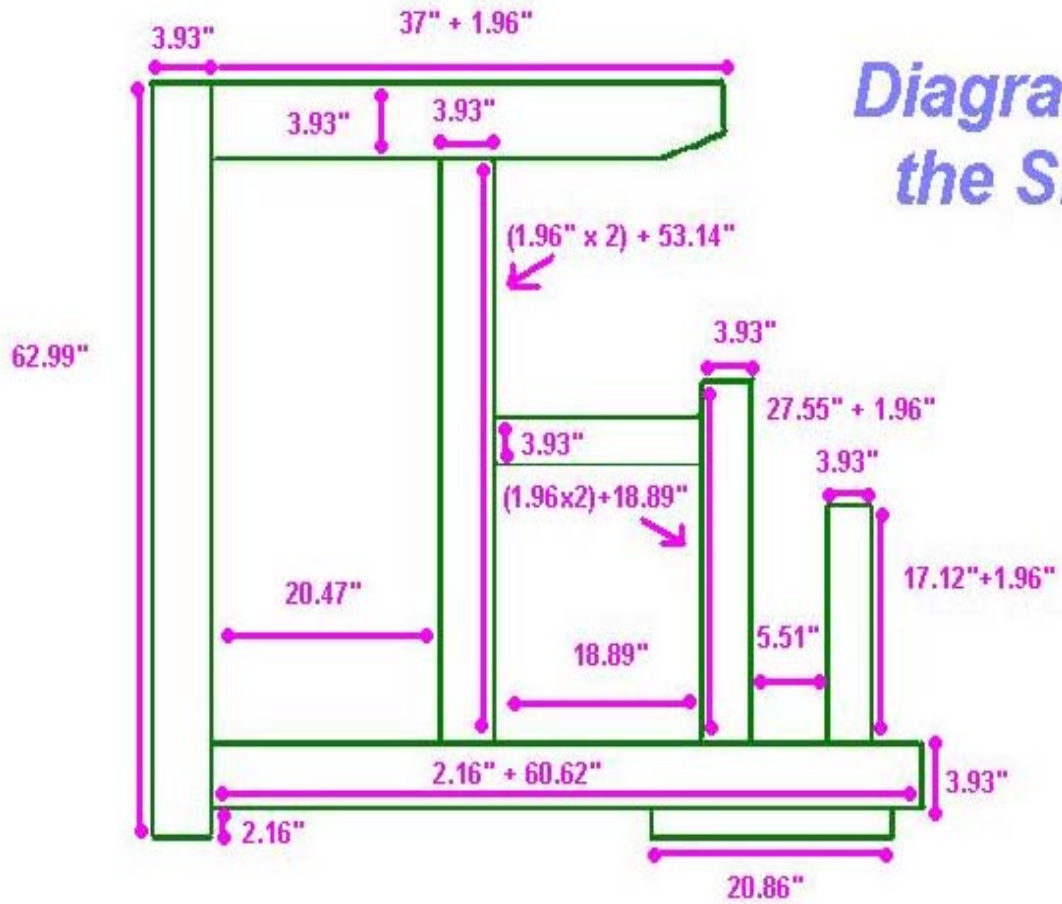

These loom plans are very easy to follow and will guide you step by step on how to build a 64" high, 75" long floor model, weaving loom. These looms cost a minimum of \$1000.00 to purchase so you've made the right move building this yourself.

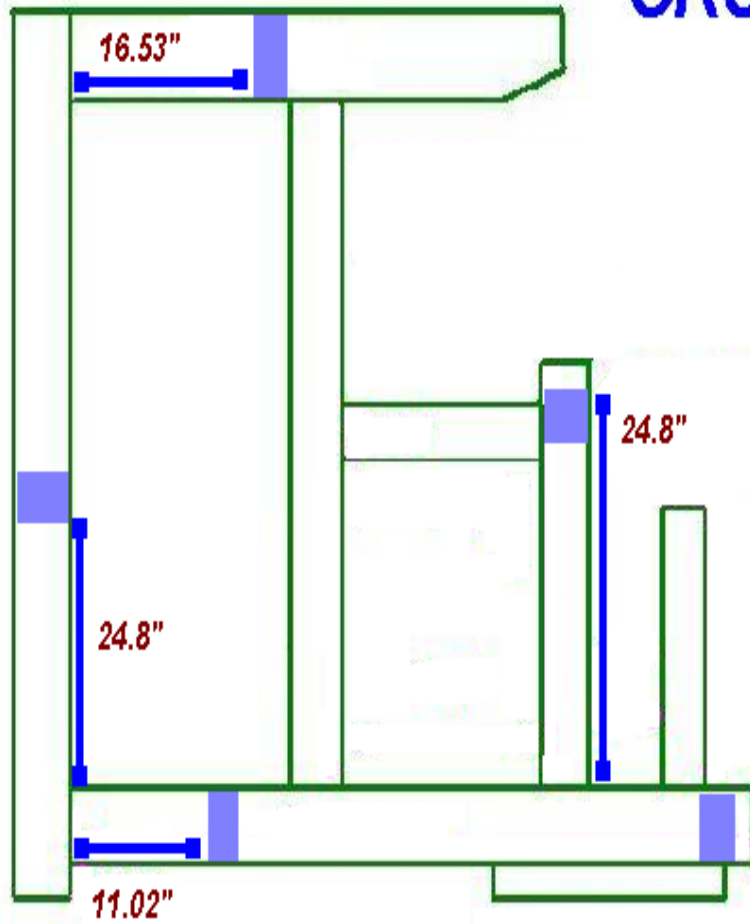

*Diagram of the Side*

NOTE: Cut Sections are 3.93" x 1.96" for each piece.

# CROSSBARS

**■** = length/size is 47.24" and cut section is 1.96" x 3.93". One piece.



## EXAMPLES OF HOW YOU CAN ASSEMBLE THE CROSSBARS

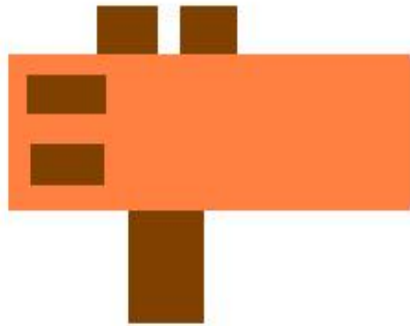

JOINING THE WOOD IN THE MIDDLE OR USING SET SQUARES TO STRENGTHEN THE WOOD.

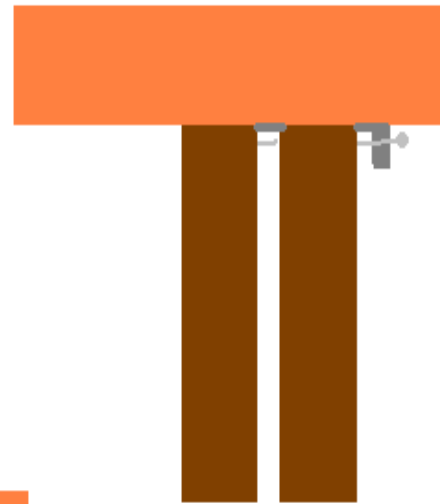

JOINING THE CROSSBARS TO THE SIDES OF THE LOOM FRAME BY MORTISES AND PINS

Petals: For the building of the pedals, you can choose on of the following; drill for the passage of a thread stalk, which has a diameter of twelve millimeters; or use two set squares to keep them maintained. One puts a slice in between each pedal to decrease their contact and prevent rubbing or friction. Or, in the case of the other type of pedals, you can use hooks.

## FOOT NOTE:

Pedals = 35.43" is the size/length, the cut section should be 2.36" x 1.18", and 6 pieces.

Marches = 31.49" is the size/length, the cut section should be 19.68" x 4.72", and 4 pieces.

2 Pieces of Set Squares.

Thread Stalk = 19.68" is the size/length, the diameter of the cut section should be 0.47", and 1 pieces.

# *The Batten*

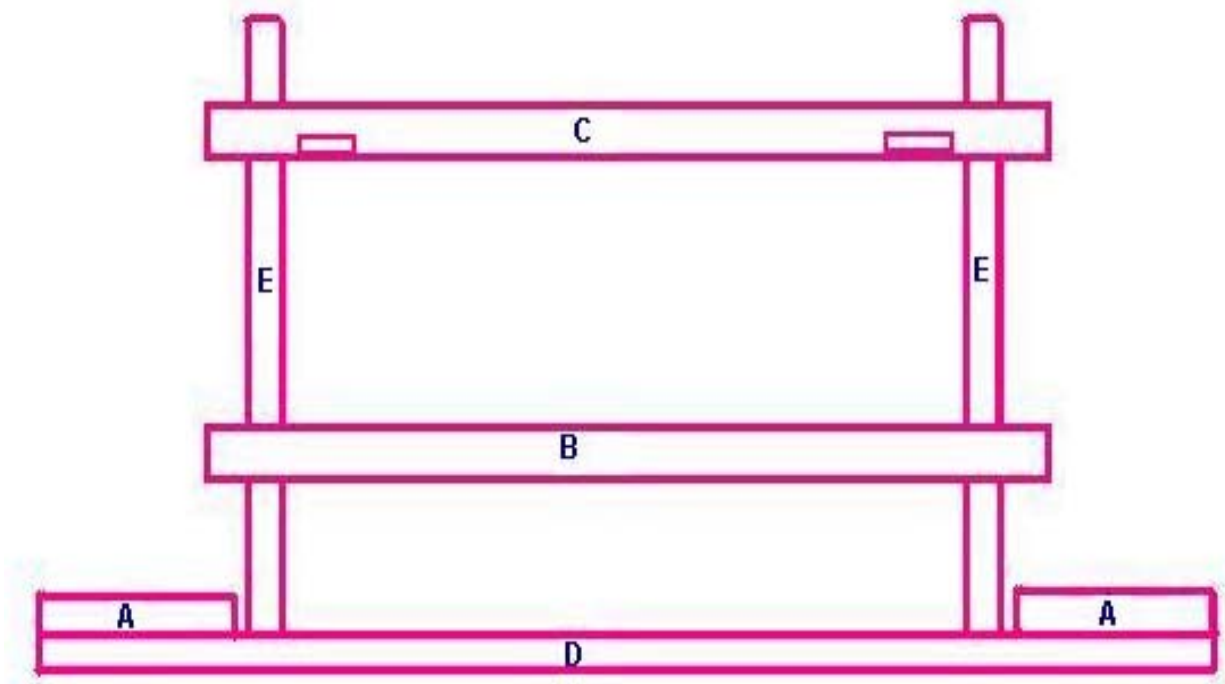

Footnotes:

A) Four Pieces, the cut section is 2.36" wide x 1.10" thick, and 15.74" long.

B) One Piece, the cut section is 2.36" wide x 1.96" thick, and 59.84" long.

C) One Piece, the cut section is 2.36" wide x 1.96" thick, and 59.84" long.

D) One Piece, the cut section is 1.37" wide x 4.72" thick, and 88.58" long.

E) Two Pieces, the cut section is 2.36" wide x 1.96" thick, and 37.40" long.

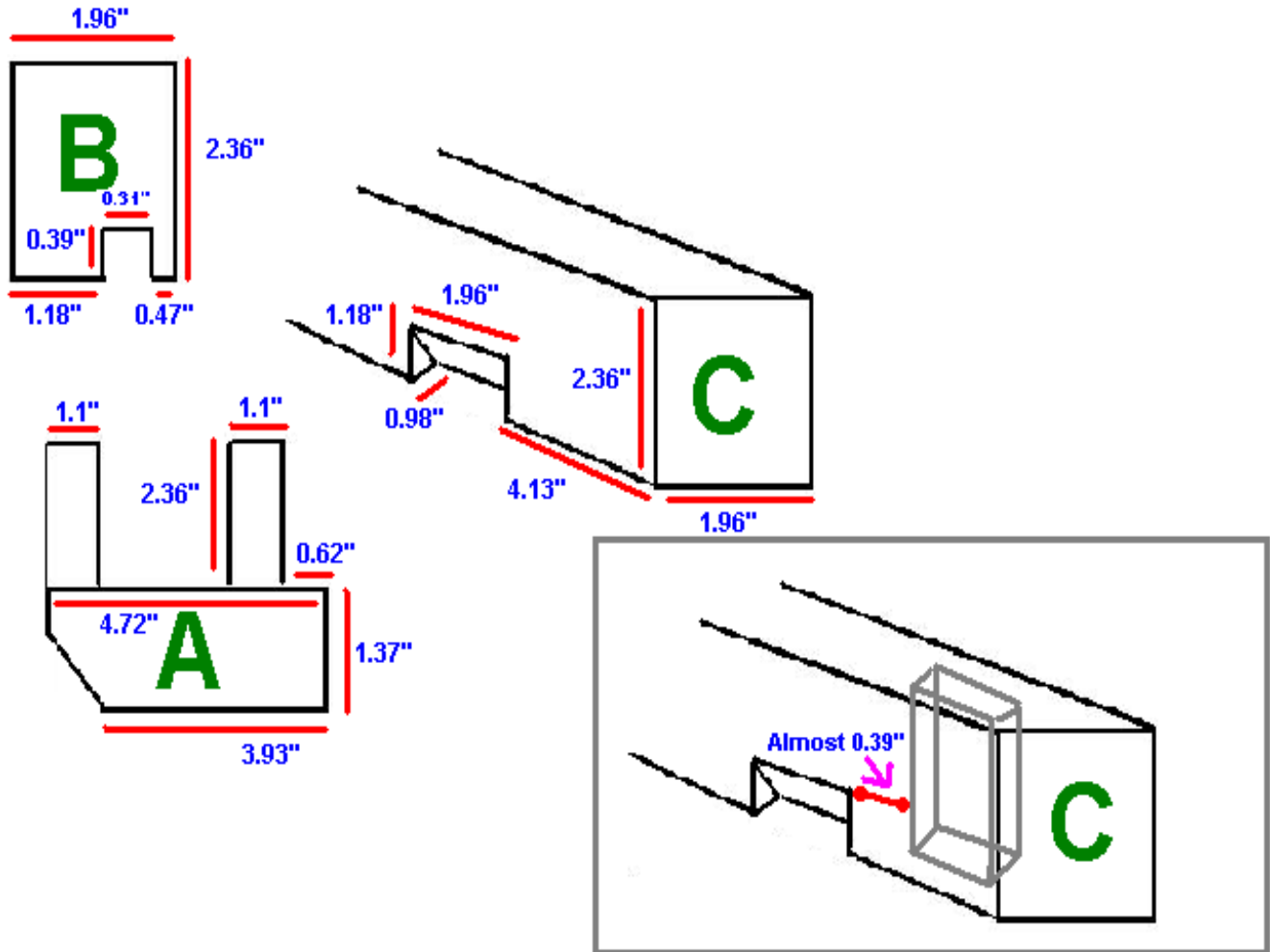

Through that hole, the arm E of the batten passes through it. The precise measurements should fit perfectly with the part of arms E of the batten, to let them slide inside perfectly. The detail B has the same hole in it.

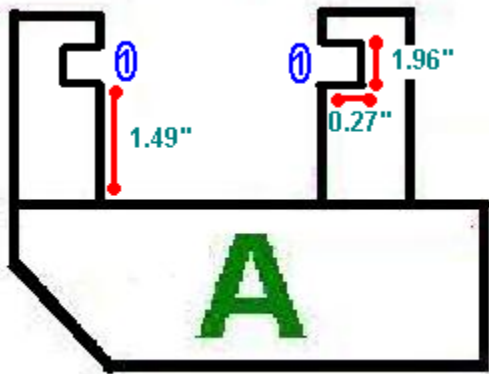

Of the shuttle boxes, the four tiny boards are indented on all their length, in  $\text{\textcircled{0}}$  the groove measures .46" deep on .19" in height. They will let rats slide with a definite amount of room.

## **The Plan For the Weaving Loom – Front and Rear Rollers**

The front roller has three (A), which are 5.90" in diameter. Leaky in their center of a round hole of 0.47" for entrance of a stalk thread that is 0.54". Flasks have eight notches that are each 0.78" wide x



1.57" high and will get eight crossbars. On the thread stalk is where flasks are threaded and blocked by nuts. A flask in every extremity, the third in the center, eight crossbars are then fixed.

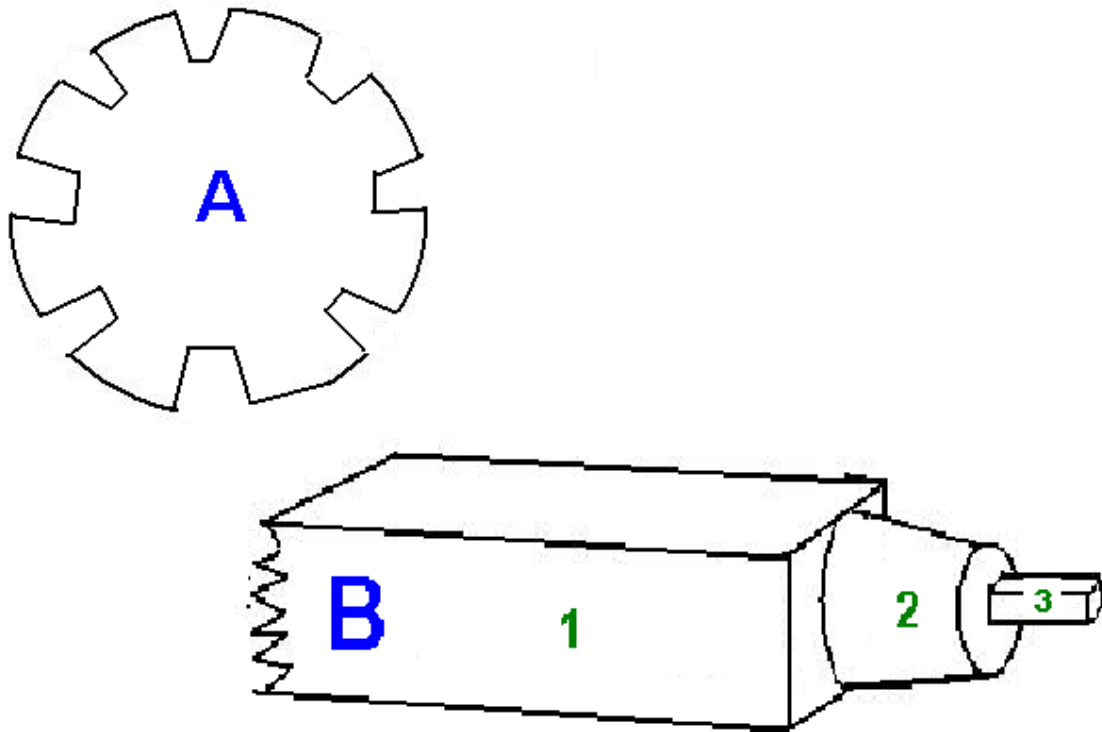

Foot Notes: (A) – Has a diameter of 5.9" with a round hole .47millimeters. The total amount needed of (A) is three. The section is .74" thick plywood.

(Traverses) - Has a length being the interior width of the loom minus .78". The total amount needed of

(Traverses) is eight. The section is 1.57" x 0.78".

(Threaded rod + 2 nuts) - Has a length of 5.9" and a section diameter of 0.47". The total amount needed of (Threaded rod + 2 nuts) is two.

The rear roller has two (A) that are 12.99" in diameter and leaky in their center of a square hole which is 2.56" for the allowance for entrance of the wooden axle. Flasks have eight notches that are two centimeters wide by five centimeters high and will get eight crossbars. (A) - has a diameter of 12.99" leaky in the center of a square hole that is 2.56". The total amount needed of (A) is two. The section is 0.74" thick of plywood. (CROSSBARS) – have a length, which is the interior width of the loom minus 0.78". The total amount needed of (CROSSBARS) is eight. The section is 1.96" x 0.78". (B) – has a length that equals the interior width of the loom minus 0.78". The total amount needed of (B) is one. The section is split up in three parts. **Part 1** is section 2.56" x 2.56", **Part**

**2 is:** Diameter 2.36", length 2.36", and finally, **Part 3:** section 0.78" x 0.78" and 2.36" in length.



CONGRATULATIONS: You have now built a complete weaving loom all on your own and have managed to save yourself a bundle of money in the mean time! Enjoy it and treat it well!