

The Disappearing Lathe Plans

Please see my YouTube video with the same title for lots of details about the construction of this project

1

The Drill

Almost any drill will work, but if you use a light duty 1/4" or 6mm drill, you will limit the size of the work you can turn. I used a 3/8" or 10mm drill with a 600 watt motor. This has worked well for me. It is possible to buy drills with 1,000 watt motors if you need more power.

Dimensions

I am showing the actual dimensions of my lathe. However, none of those dimensions are critical. You can easily modify any of them, round them off into convenient metric numbers, or adjust them for your specific needs.

The turning centers need to be elevated above the work bench by about 5" (13cm) or more to provide room for the spinning work to turn freely, and to provide room for the clamps and tool rest. If you want to elevate the centers a lot more than that, you may need to increase the size of the base for good stability.

If you intend to turn larger pieces, like large wheels, then consider making the bases deeper, and setting the head and tailstock back further from the edge of the bench. This will give you more room to clamp the tool rest.

©2018

Plans and design are copyrighted by Patrick Sullivan. They may be used by individuals for personal projects. Use or reproduction of any part of these plans for commercial purposes is expressly forbidden.

Adapting the Plans

The headstock must be designed around the drill. The location of the hose clamps and the position of the drill will vary from drill to drill.

Additionally, the height of the center of the drill chuck will vary. This will change the height of the tailstock.

Select the drill you want to use, and lay out your plans around it.

Safety Considerations

Lathes can throw pieces at your face. Never forget this.

The clamps that secure the components to the work bench must be tight, and strong enough to withstand the forces you generate. If the clamps slip, the spinning work can come off the drill. Verify that the clamps are secure.

Vibrations tend to loosen the tailstock threaded shaft. The locking nut is intended to prevent this. However, check periodically to see if the tailstock is loosening. If so, then re-tighten, and be sure that the locking wheel is thoroughly tight.

I strongly recommend that you wear a face shield, or at the minimum, safety glasses. This is a widespread practice in the turning world. Don't take a chance with your eyes.

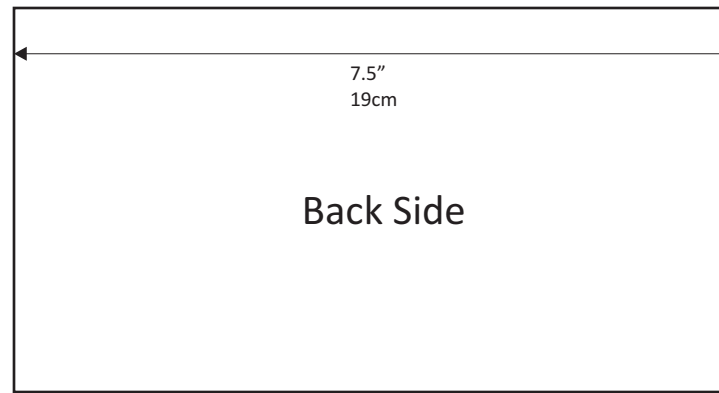
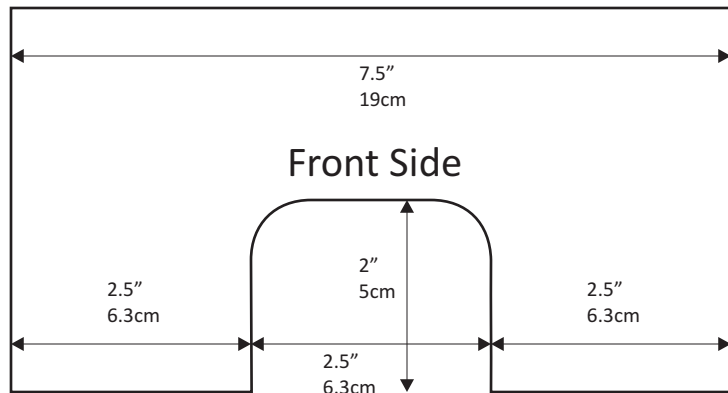
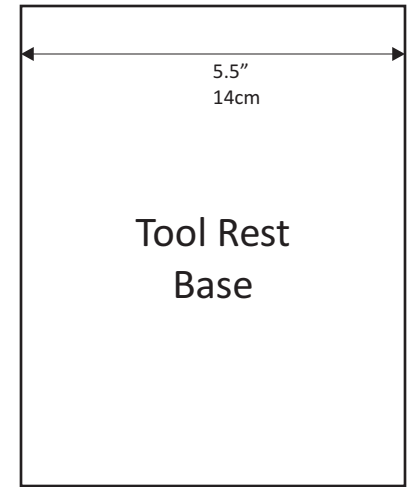
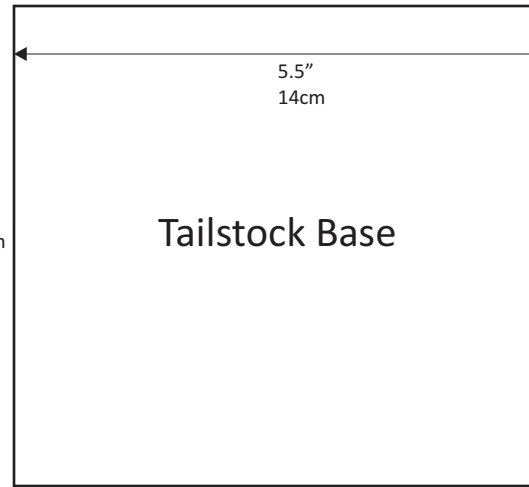
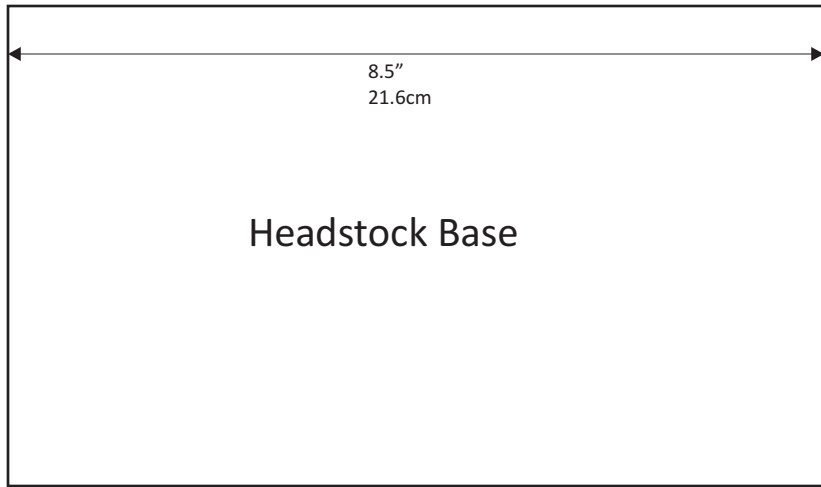

Headstock Components

All the pieces on this page are made from 3/4" or 18mm plywood.

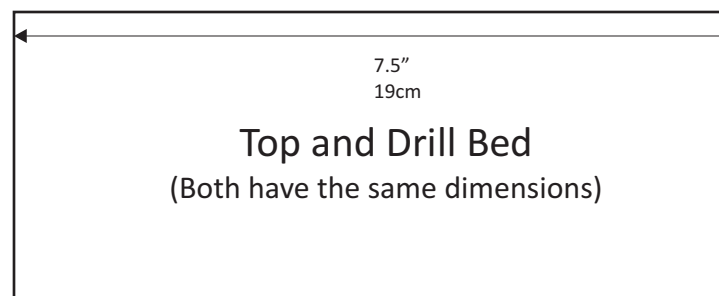
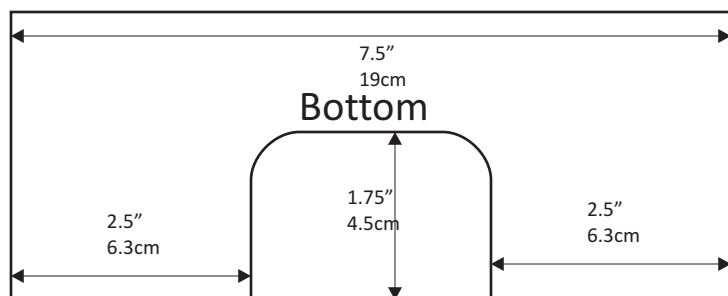

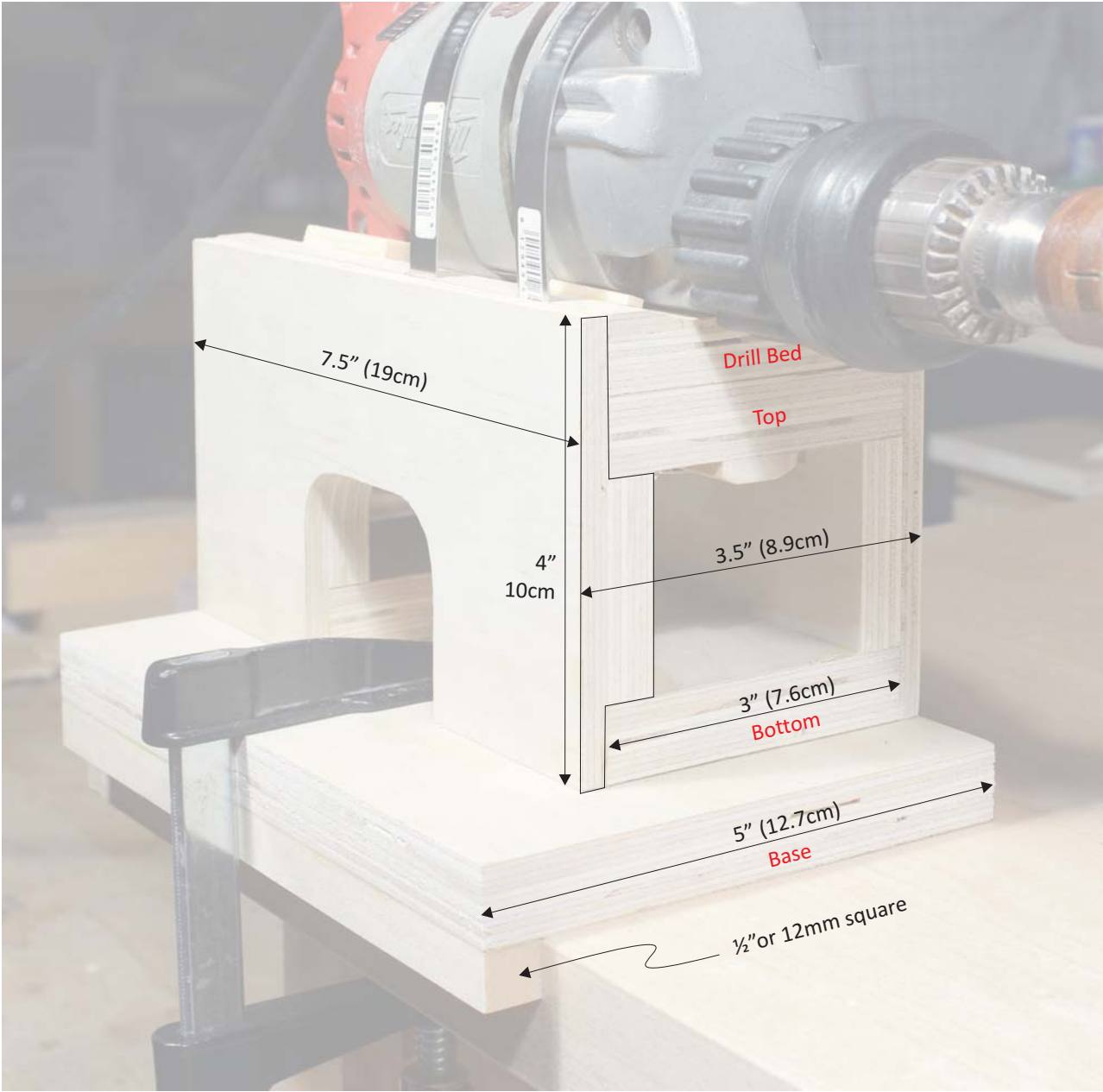

Profile of the Sides

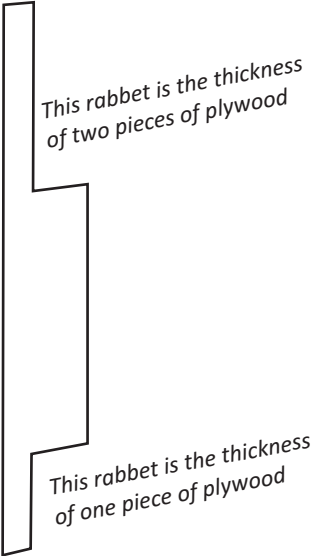

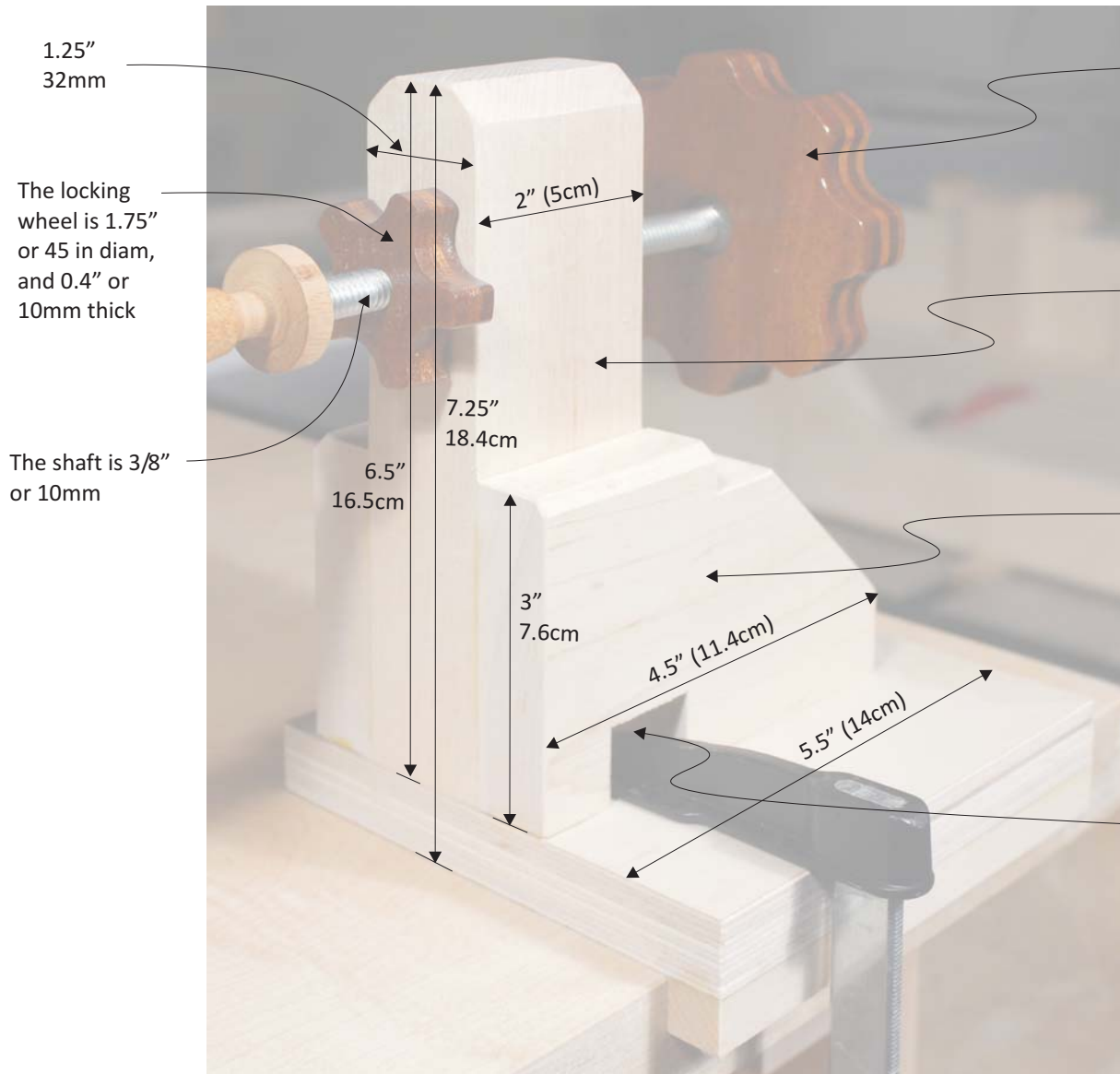

1.25"
32mm

The locking
wheel is 1.75"
or 45 in diam,
and 0.4" or
10mm thick

The shaft is 3/8"
or 10mm

6.5"
16.5cm

7.25"
18.4cm

3"
7.6cm

4.5" (11.4cm)

5.5" (14cm)

2" (5cm)

The large wheel on my lathe is 3.5" (9cm) in diameter, and 0.7" (17.5mm) thick. I think it would be better if it were a little smaller. I have included a pattern for it that is 3" (7.6cm) in diameter.

The tailstock upright should be a dense, strong hardwood. I used maple. My piece is 32mm X 50mm x 165mm, but the only requirement is that it be stiff and strong enough that it will not bend under the forces of the lathe.

The shape of these two support pieces is fairly unimportant. All that is required is that the upright be rigidly attached to the base, and able to resist the forces from the tailstock center.

The notch runs all the way through the tailstock block. It needs to be located closer to the left side of the base, because the forces tend to tip the tailstock to the right.

4

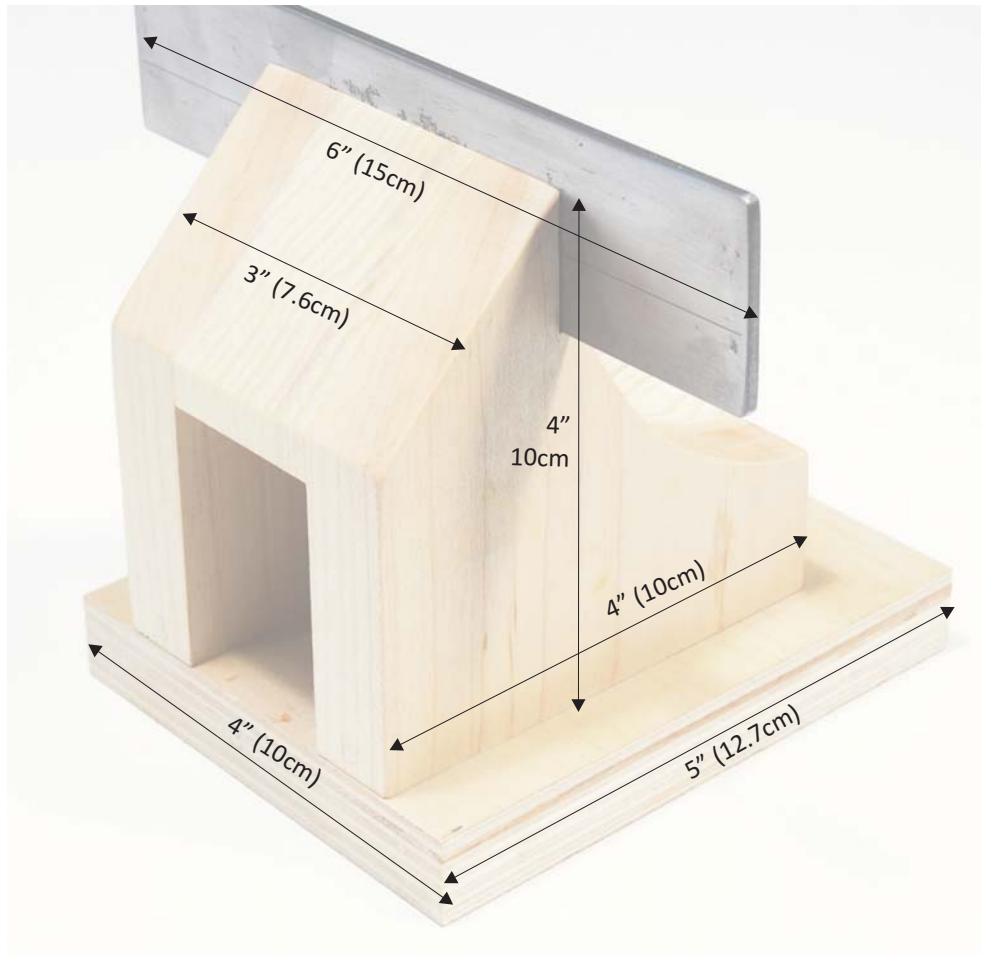

The steel bar can be shorter or a little longer. If you need a tool rest that is, say, 12" or 30cm long, then you should widen the base to provide more support.

The shape of the tool rest is not important. It simply needs to be stable and the correct height.

Commercial lathes have a tool rest that is adjustable for height. This is a very nice feature. I skipped this for simplicity.

It is possible to build one from wood, but the construction becomes more complicated. If you find that you need another height, it is probably easier to just build a second rest.

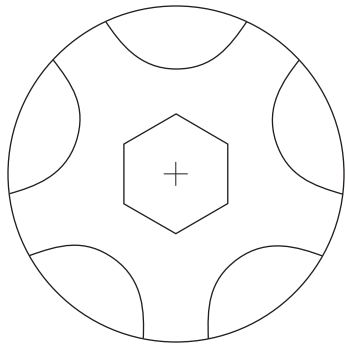

Locking
Wheel

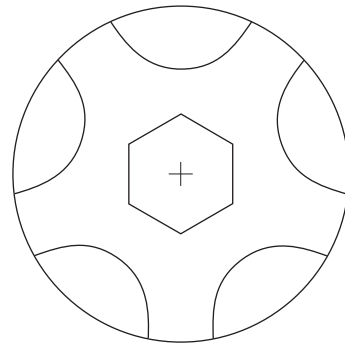

Locking
Wheel

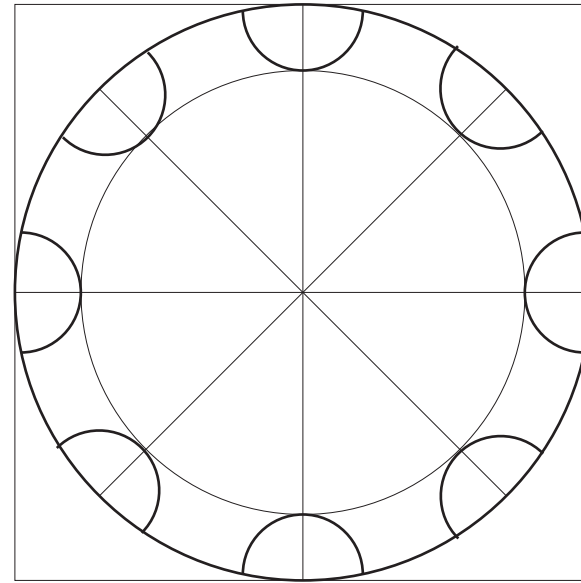

Tailstock Wheel

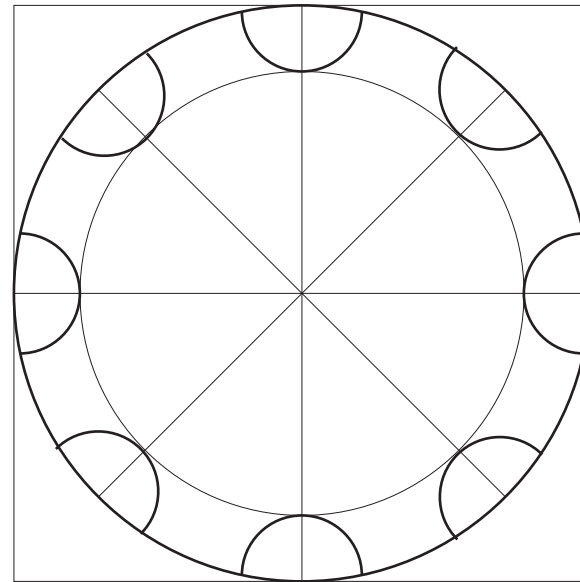

Full Size Templates

Simply print on ordinary paper, cut out a square that contains the shape, and paste it to the wood with a glue stick.

Cut to the lines on the pattern, and remove the paper when done with a scraper or light sandpaper. It will remove easily.