



# THANK YOU!

---

You have successfully downloaded your *Woodsmith* project plan.

▶ [Go to Page 1](#)

## **Get More from Your Table Saw...at PlansNOW.com**

---



### **Build our 10 BEST Table Saw Jigs!**

What really makes a table saw so versatile are the jigs and accessories that improve your saw's overall performance.

▶ [Download Today at PlansNOW.com...\\$4.95](#)

## **Woodsmith Shop TV Show Special...Save 10%**

---



### **Use Coupon Code *TVSHOW* at PlansNOW.com**

Visit PlansNOW.com today and save 10% on more than 200 woodworking plans and how-to technique articles.

▶ [Go to PlansNOW.com Now](#)

## **You Can Build It...at PlansNOW.com**

---



### **Workbenches**

Good woodworking starts with a solid workbench.



### **Shop Jigs & Techniques**

Get the most from your tools with easy-to-build shop jigs.



### **Cabinets & Shelves**

Build stunning furniture that's both functional and beautiful.



### **Home Improvement**

Save hundreds of dollars in remodeling when you DIY.



Woodsmith **PLANS**

# ROUTER TABLE



# ROUTER TABLE

*With your choice of bases, a rock-solid table, and fence-mounted accessories, this project is as rewarding to build as it is to use.*



**A** router is one of the most versatile tools in the shop. Mount it in a router table, and you'll find dozens of new uses for this tool.

**BASE.** The basic open-base router table shown in the main photo above is easily built from 2x4s. And you can complete it in a weekend.

Another option is the enclosed cabinet base shown in the inset photo. This cabinet helps reduce dust and noise from the router. It also offers plenty of storage for accessories and router bits.

**TABLE TOP.** Whichever base you build, the table top and fence are the same.

The router is screwed to an insert plate that drops into the table top. This allows easy access for bit changes.

**FENCE.** The fence accepts a variety of accessories, such as bit guards and a dust hood. You can make these yourself, or you can purchase them from *Woodhaven*.

# Construction Details

Overall Dimensions:  
36" x 23" x 41<sup>7</sup>/<sub>16</sub>" (including fence)

## MATERIALS

### WOOD

*A	Leg Pieces (8)	1 1/2 x 3 - 36
*B	Rails (4)	1 1/2 x 3 - 18
*C	Stretchers (3)	1 1/2 x 3 - 20 1/2
D	Base (1)	3/4 ply - 21 1/2 x 28 1/2
E	Covers (2)	1/4 hdbd. - 21 1/2 x 28 1/2
F	Side Edging (2)	3/4 x 1 1/4 - 21 1/2
G	Fr./Bk. Edging (2)	3/4 x 1 1/4 - 30
H	Insert Plate (1)	1/4 hdbd. - 7 3/4 x 11 3/4
I	Base Top (1)	1 1/16 x 1 3/4 - 36
J	Base Bottom (1)	3/4 x 1 3/4 - 36
K	Sliding Faces (2)	3/4 x 1 3/4 - 18
L	Top Bars (2)	3/4 x 2 1/2 - 36
M	Arm Blank (1)	3/4 x 1 3/4 - 8
N	Spacers (2)	1 1/4 x 1 3/4 - 2 7/8
O	Splines (2)	1/8 hdbd. - 7/8 x 1 3/4

### HARDWARE

- \*(12) 1/4" x 3 1/4" lag screws
  - \*(12) 1/4" washers
  - \*(1) 3/4" x 24" hardwood dowel
  - (8) #8 x 7/8" Fh woodscrews
  - (2) #8 x 1 1/4" Fh woodscrews
  - (2) #8 x 1 1/2" Fh woodscrews
  - (2) #8 x 2 1/2" Fh woodscrews
  - (2) 3/8" x 6" carriage bolts
  - (2) 3/8" washers
  - (4) 5/16" washers
  - (2) 3/8" plastic knobs or wing nuts
  - (4) 5/16" inside-diameter threaded inserts
  - (4) 5/16" x 2 1/4" threaded knobs
  - (4) L-shaped mounting brackets
  - (2 pcs.) 23 1/2" x 30 1/2" plastic laminate
- \* Indicates items needed only for open base

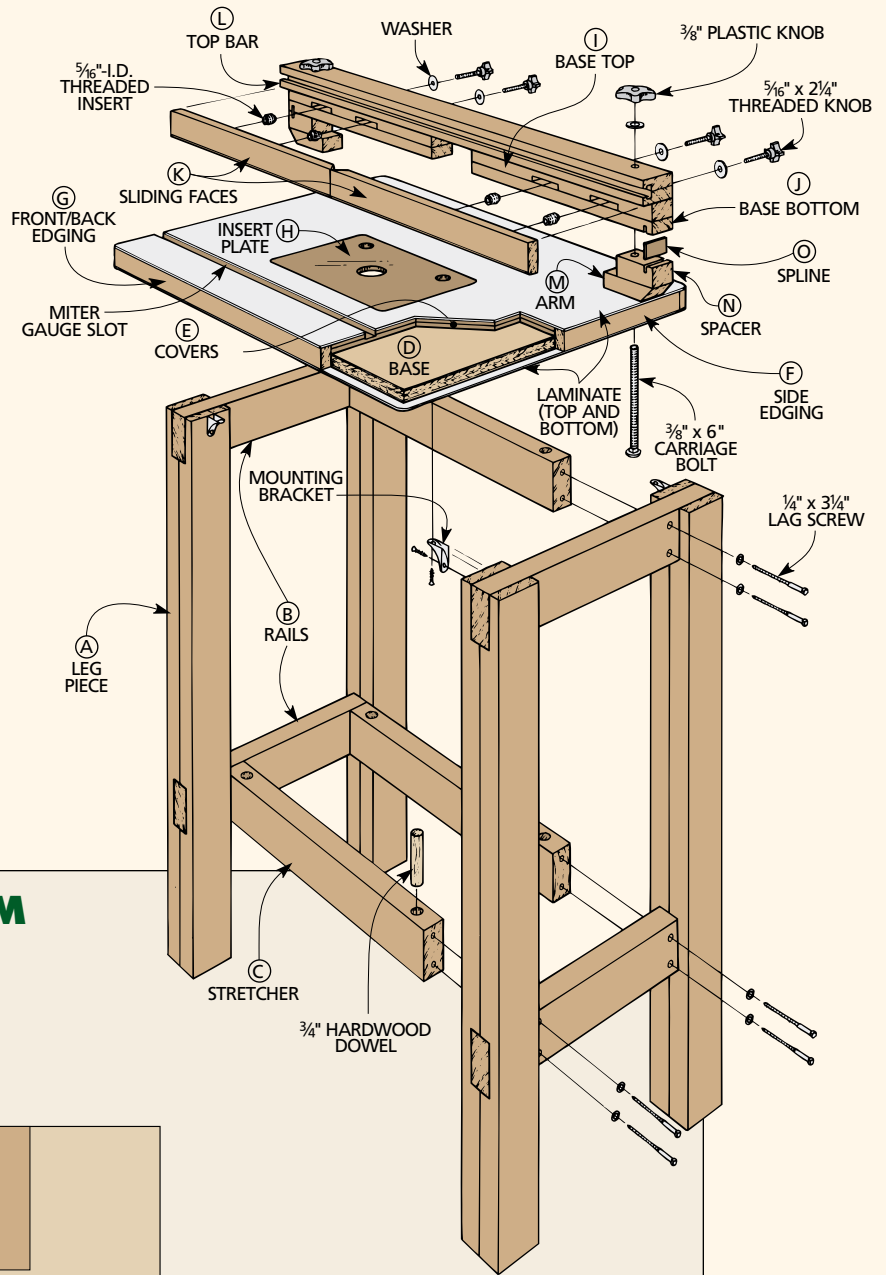

## CUTTING DIAGRAM

1/4" HARDBOARD - 48 x 48

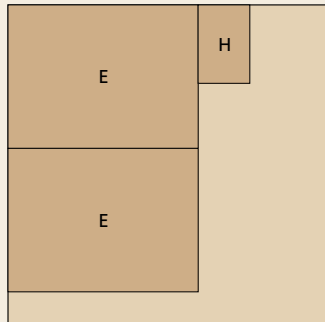

3/4" PLY - 24 x 48

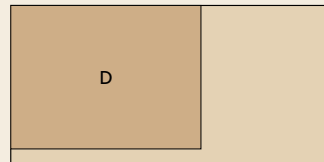

2x4 (1 1/2 x 3 1/2) - 8 Ft. (Four Boards @ 5.3 Bd. Ft. Each)



2x4 (1 1/2 x 3 1/2) - 6 Ft. (4 Bd. Ft.)



3/4 x 3 1/2 - 72 (1.8 Bd. Ft.)



3/4 x 5 1/2 - 96 (3.7 Bd. Ft.)

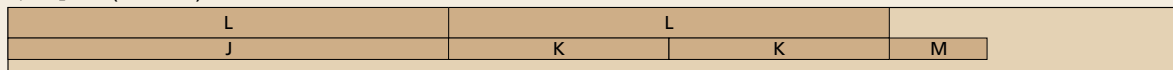

1 3/4 x 3 1/2 - 48 (2.3 Bd. Ft.)



## Open Table Base

Shop Note: If you prefer to build the enclosed cabinet base, turn to page 12.

**1** Square up the 2x4 stock by ripping it to a finished width of 3". To do this, rip  $\frac{1}{4}$ " from each side; see Fig. 1.

**2** Using the trimmed 2x4s, cut eight leg pieces (A) to a length of 36".

**3** Cut four rails (B) from the trimmed 2x4 stock to a finished length of 18".

**4** To form mortises to hold the rails, first cut a 3"-wide dado,  $\frac{3}{4}$ " deep at the top of each leg piece (A); see Fig. 1. Then cut a second dado 3" wide and  $\frac{3}{4}$ " deep, 21" below the top dado.

**5** Glue a rail (B) into the top dado of a leg piece (A). Make sure the end of the rail is flush with the edge of the leg; see Fig. 1. Glue a second rail into the lower dado. Then glue a second leg piece to the first leg piece to sandwich the rails. Repeat with the other leg pieces and rails to form the two end frames.

**6** Then, cut three stretchers (C) from the trimmed 2x4 stock to a finished length of  $20\frac{1}{2}$ "; see Fig. 1. (Shop Note: To provide access to the router, there is no top stretcher between the front legs.)

**7** The lag screws that fasten the end frames to the stretchers are threaded into end grain. To give these lag screws more hold, a dowel is inserted into each stretcher close to the end; see Fig. 2. So first, drill two  $\frac{3}{4}$ "-dia. holes through the edge of each stretcher. Center each hole  $1\frac{1}{8}$ " from the end of the stretcher. Then glue a  $\frac{3}{4}$ "-dia. dowel into the hole. When the glue is dry, trim and sand the dowel flush.

**8** Drill two  $\frac{1}{4}$ "-dia. shank holes through each rail (B) where a stretcher (C) will be attached; see Fig. 2.

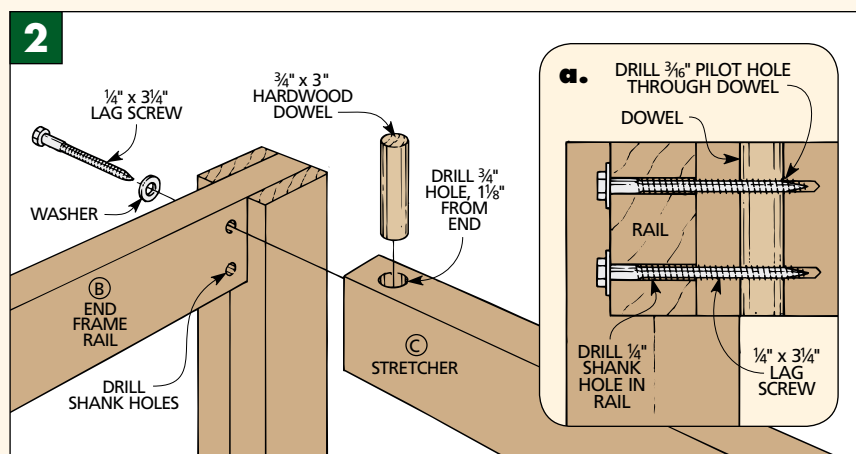
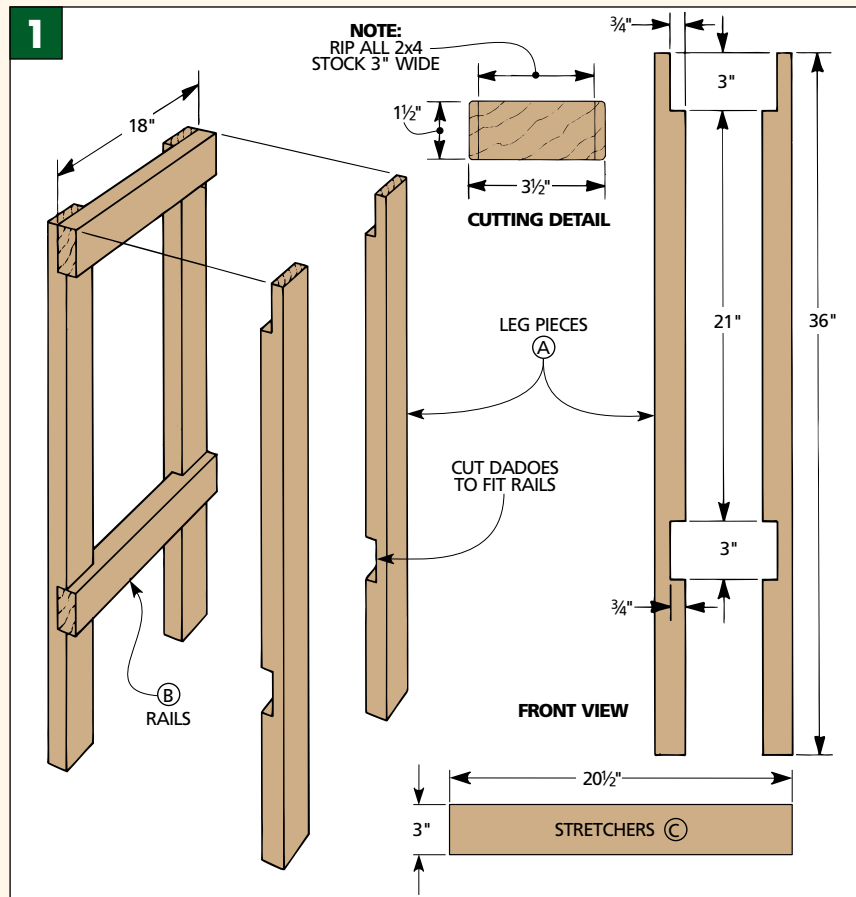

**9** Place a stretcher (C) against a rail. Drill a  $\frac{3}{16}$ "-dia. pilot hole through each shank hole into the stretcher and through the dowel in the stretcher; see Fig. 2. Repeat this process to drill pilot holes into all the stretchers.

**10** Now complete the base by fastening the end frames to the stretchers using  $\frac{1}{4}$ " x  $\frac{3}{4}$ " lag screws and washers; see Fig. 2.

## TIP

If you cut the dados on the table saw, set the blade  $\frac{3}{4}$ " above the table. For the top dados, set the rip fence 3" from the outside of the blade. To cut the dados in the middle of the leg pieces, set the rip fence and make one cut in each leg piece to define the top of the dado. Next, reset the fence to cut the bottom edge of each dado. Then remove the waste between the cuts.

## Table Top

**11** Start building the table top by cutting the table top base (D) from  $\frac{3}{4}$ " plywood. Cut it to a width of  $21\frac{1}{2}$ " and a length of  $28\frac{1}{2}$ "; see Fig. 3.

**12** Cut two covers (E) from  $\frac{1}{4}$ " hardboard slightly larger than the table top base (D); see Fig. 3. The cover pieces should slightly overhang the base piece on all sides. Use contact cement to glue the covers to the top of the base. (See the box below for tips on using contact cement.)

**13** Chuck a pattern bit into your router. Turn the table top over and trim the hardboard covers (E) flush

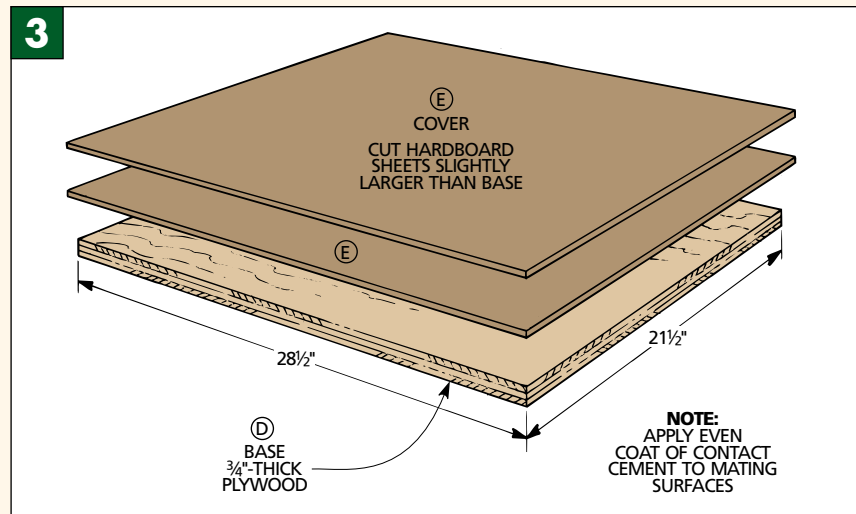

with the edges of the plywood base (D); see the box on the next page.

**14** Rip edging strips (F, G) from  $\frac{3}{4}$ "-thick hardwood to match the thickness of the table top. Then cut

the edging to length; see Fig. 4. The side edging (F) will be the same length as the width of the table. The front/back edging (G) will cover the long edges of the table top plus the side edging (F); see Fig. 4b.

## USING CONTACT CEMENT

As its name implies, contact cement bonds on contact. It works by bonding to itself, so it has to be applied to both surfaces that are being joined. Contact cement is ideal for joining two large, flat surfaces (like laminate or veneer on a table top).

**APPLICATION.** Before beginning, make sure you read and follow all safety instructions on the can's label.

Start by applying an even coat of contact cement to both surfaces to be joined (but keep the workpieces apart). A disposable roller or brush works well, and if it gets gummed up, you can just throw it away. Use only one or two strokes. If you continue to brush over the same area, the contact cement starts sticking to itself and balls up.

If the first coat soaks into the workpieces, a second coat may be needed. Just make sure you let the first coat dry completely before applying the second coat. Otherwise the second coat won't go on smoothly.



**JOINING THE PIECES.** The contact cement has to be almost dry before joining the two pieces. You can check it by simply dabbing it with your finger. It should look dull and feel slightly tacky, but shouldn't stick to your finger.

To allow you to position the top workpiece, set some narrow strips of scrap on top of the lower piece to prevent the pieces from touching; see photo. Then when the upper piece is properly positioned, pull

out the strips starting in the middle and working to one end. Press the workpieces together as you go to work out any air bubbles.

**SMOOTHING.** Finally, for the best bond, use a hard-rubber roller (or a hammer and scrap block) to go over the entire surface of the workpiece. Start at the center and work toward the edges to work out any remaining air bubbles. The bond should fully cure in about 24 hours.

**15** Next, glue and clamp the edging strips to the table top so they're flush with the top edges. When the glue is dry, sand or file a  $\frac{1}{2}$ " radius on each corner; see Fig. 4b.

**16** Cut two pieces of laminate slightly larger than the table top; see Fig. 5. Use contact cement to glue a piece of laminate to each face of the top. (Shop Note: Gluing laminate to both faces helps prevent warping.) Then use a chamfer bit to trim the laminate to size and to ease the edges of the table at the same time; see Fig. 5a.

**17** Apply a finish to the base and edging strips. The base in the photo on page 1 has a tung-oil finish.

**18** When the finish has dried, mount the table top to the base by screwing an L-shaped bracket to the inside face of each leg; see Fig. 6. When mounting the brackets, keep them  $\frac{1}{32}$ " below the top of the leg. Then, when the table top is screwed in place, it will be pulled tight to the leg assembly.

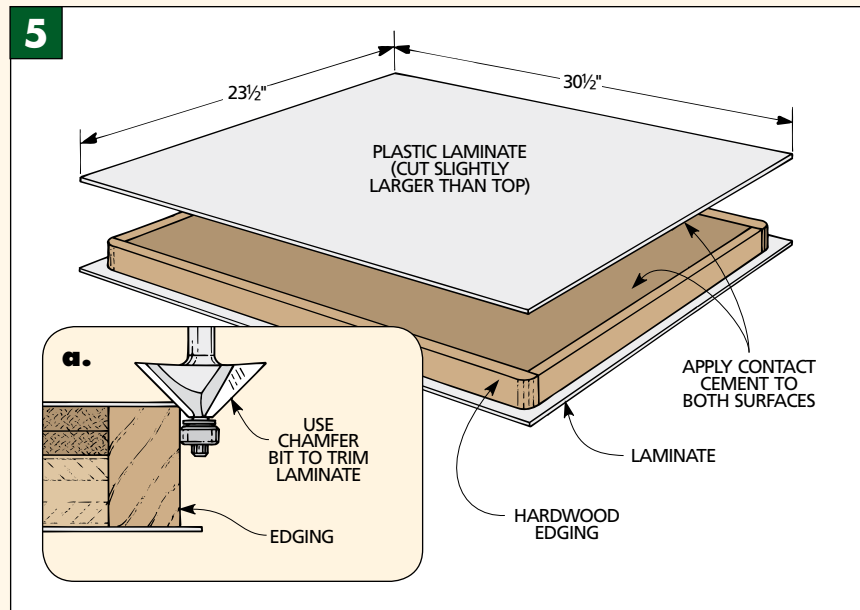
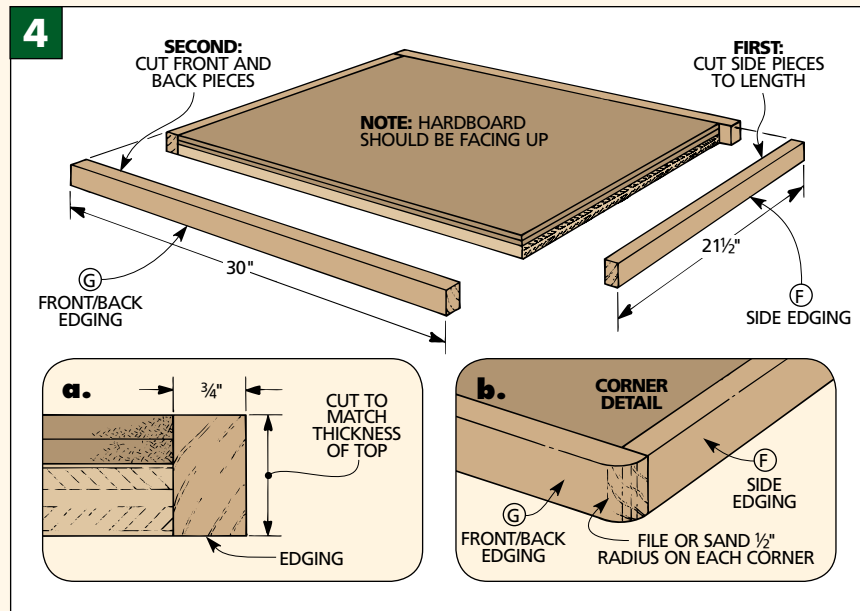

## PATTERN BITS

To trim two surfaces flush with each other, you can use either a flush trim router bit or a pattern bit. The difference is that a flush trim bit has a bearing on the bottom and a pattern bit has the bearing on the top; see drawing. You'll need a pattern bit later when routing a groove in the table top (the bearing on a flush trim bit

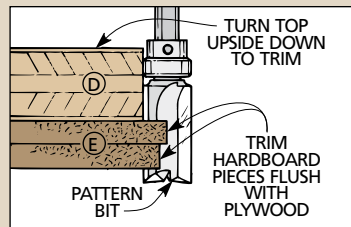

would get in the way). So use a pattern bit now when trimming the pieces on the table top.

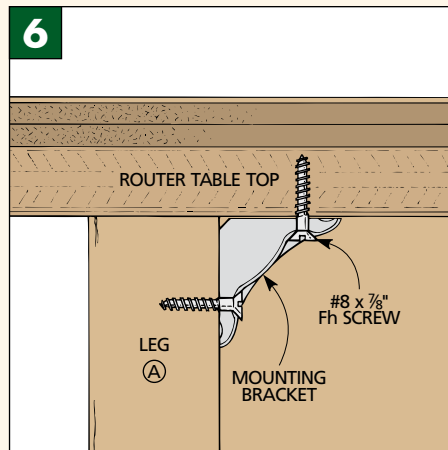

## Insert Plate

Shop Note: You can make an insert plate from  $\frac{1}{4}$ "-thick phenolic plastic or hardboard. Or purchase a ready-made insert plate or an oversized blank insert plate with no holes.

**19** Cut the insert plate (H) to finished size; see Fig. 7. (Shop Note: The dimensions in Fig. 7 will allow sufficient room to lift most standard routers out of the table. If your router is larger, make the insert plate about 1" wider than your router.) Sand or file a  $\frac{1}{4}$ " radius on each corner of the plate.

**20** Remove the base from your router. Use it as a template to locate and drill mounting holes and a  $1\frac{3}{4}$ "-dia. center hole in the insert plate (H); see Fig. 7. Countersink the mounting holes. Also drill two 1"-dia. finger holes at the locations shown in Fig. 7. Then rout or file  $\frac{1}{16}$ " chamfers on the top and bottom edges of the insert plate, center hole, and finger holes; see Fig. 7.

**21** Once the insert plate is complete, use it as a template to lay out the opening in the table top. To do this, position the plate 6" from the front edge of the table and center it on the table from side-to-side; see Fig. 8. Then trace around it with a pencil.

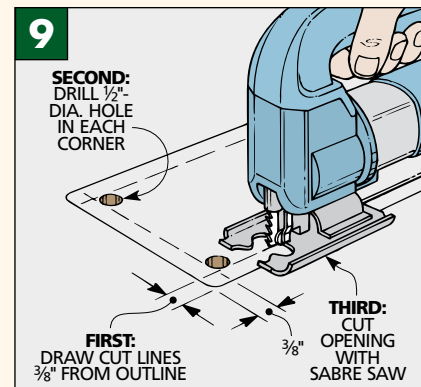
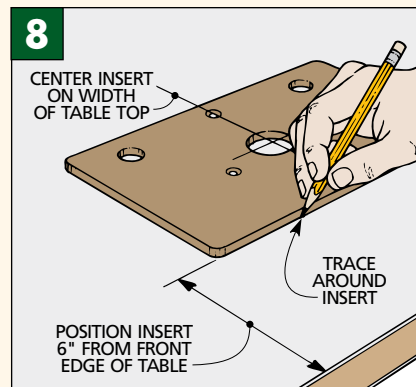
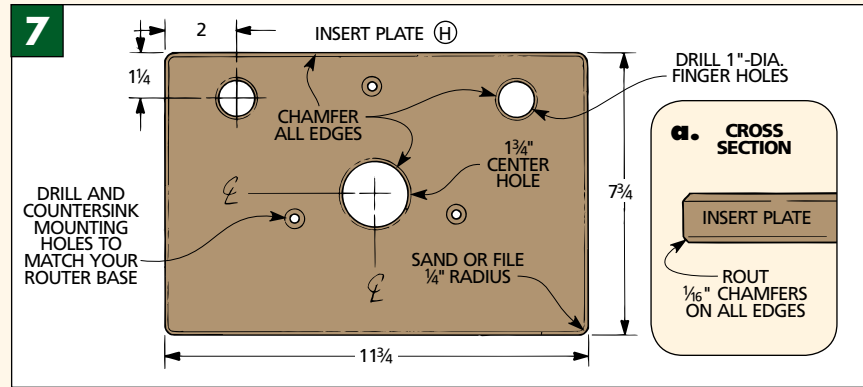

**22** Remove the insert plate, but don't cut the opening yet. First, lay out lines for the recessed lip that will hold the insert plate. To do this, draw lines  $\frac{3}{8}$ " in from the plate outline; see Fig. 9.

**23** To make cutting the corners easier, drill a  $\frac{1}{2}$ "-dia. hole in each corner formed by the inside lines; see Fig. 9. Then, to form the opening, cut on the inside lines with a jig saw.

**24** Then, start forming the recessed lip by making guide strips for the router to ride on while routing the lip; see Fig. 10. To do this, first glue a piece of  $\frac{1}{4}$ "-thick hardboard (10" x 38") to  $\frac{3}{4}$ " plywood (10" x 38") to make a 1"-thick blank.

**25** When the glue is dry, cut two guide strips to a width of 3" and to the same length as the table top. (Shop Note: These guide strips

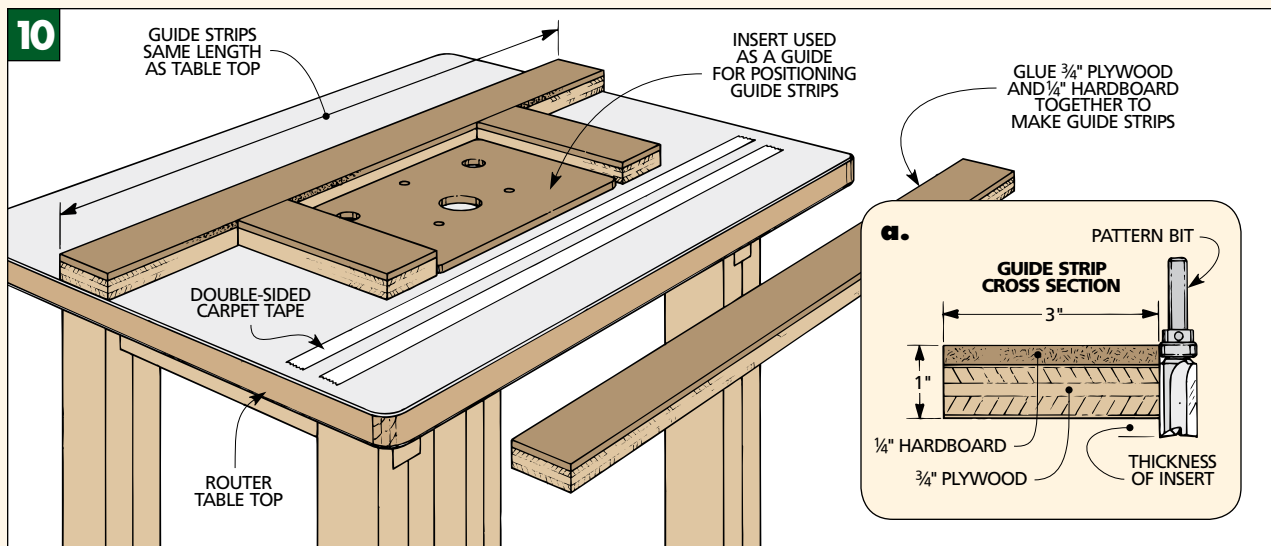



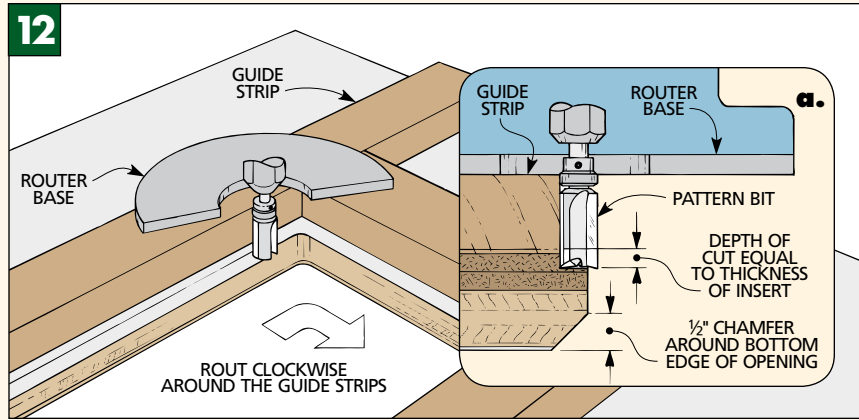
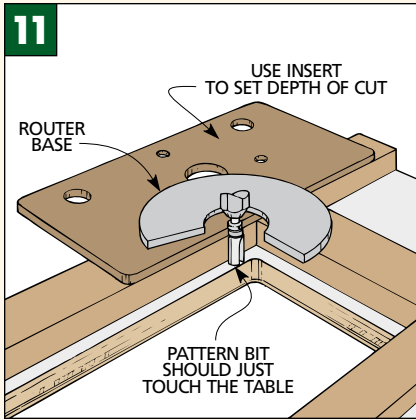

are long because they will be used again later to rout a slot the length of the table for the miter gauge.) Then cut two additional guide strips that are 3" wide and

about 1/8" shorter than the width of the insert plate.

**TIP**  
Use double-sided carpet tape to temporarily hold the insert and guide strips in place during the next couple of steps.

**26** To position the guide strips, first align the insert plate with the outline drawn on the table top. Next, place the guide strips snugly against the insert plate; see Fig. 10. Then remove the plate and set it aside.

on top of the insert plate, and lower the bit until it just touches the table top. Set the insert plate aside. Then start the router, press the bearing against the guide strip, and rout the recess, working in a clockwise direction; see Fig. 12.

**27** Chuck a pattern bit into your router. To set the bit depth, put the insert plate on top of the guide strips; see Fig. 11. Place the router

**28** After the lip is routed, remove the guide strips and turn the table upside down. Rout a 1/2" chamfer around the bottom edge of the opening; see Fig. 12. This will help improve air flow to the router.

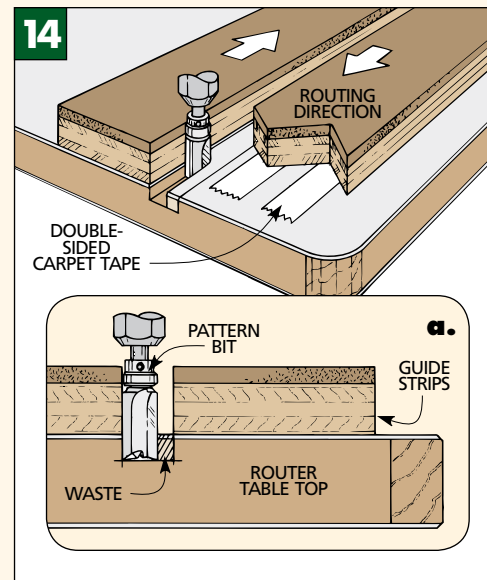
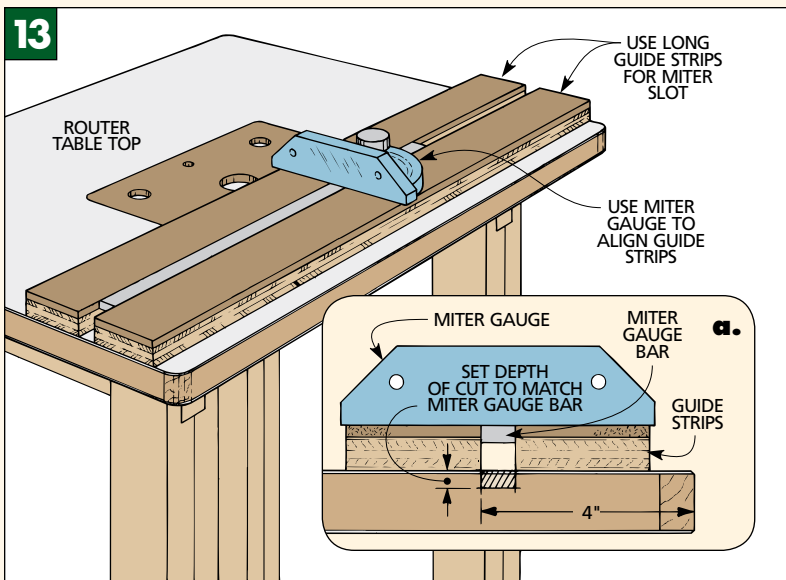

## Miter Gauge Slot

**29** To rout a slot for the miter gauge, fasten one of the long guide strips 4" from the front edge of the table top; see Fig. 13. Use double-sided carpet tape to hold it in position. Then place the miter gauge bar against the edge of the first strip. Press the second guide strip against

the miter gauge bar, then fasten the strip down with double-sided carpet tape. Remove the miter gauge.

with the insert plate earlier. Then start routing the slot by pressing the bit against the back guide strip and routing left to right; see Fig. 14. Then press the bit against the front strip and rout right to left. Finally, if necessary, clean up any waste in the middle of the slot.

**30** To set the depth of the cut, place the miter gauge on top of the guide strips. Use the bar as a spacer under the router base, just like you did

## Fence Base

**31** Start by cutting the pieces for the base of the fence. From  $1\frac{1}{16}$ "-thick stock, cut a top piece (I) to a width of  $1\frac{3}{4}$ " and 6" longer than the length of the table; see Fig. 15. Then cut a bottom piece (J) from  $\frac{3}{4}$ "-thick stock the same width and length as the top piece.

**32** Set up to cut  $\frac{3}{8}$ "-deep dadoes in the top piece (I); see Fig. 15. Each of the four dadoes is  $2\frac{3}{8}$ " wide. Space one  $3\frac{3}{4}$ " from each end. Then leave a space of  $3\frac{3}{4}$ " and cut another dado.

**33** Before gluing the base pieces together, dry assemble them with the edges and ends flush and clamp them together. Then drill a  $\frac{3}{16}$ "-dia. shank hole and a  $\frac{3}{32}$ "-dia. pilot hole between the dadoes at each end; see Fig. 15. Countersink the shank holes. Drive a #8 x  $1\frac{1}{2}$ " Fh wood-screw into each hole, then remove it. Finally, apply glue to the pieces, screw them back together, and clamp the assembly.

## Sliding Faces

**34** Next, cut two sliding faces (K) from  $\frac{3}{4}$ "-thick stock. Make each sliding face half the length of the base and  $\frac{1}{16}$ " less than the height (width) of the base; see Fig. 16. (This allows for clearance between the sliding faces and the top bar added later.)

**35** Cut a 45° bevel on one end of each sliding face (K); see Fig. 16. Then cut off the point of the miter to leave a  $\frac{1}{8}$ " edge. Finally, chamfer the long bottom edge of each face for sawdust relief.

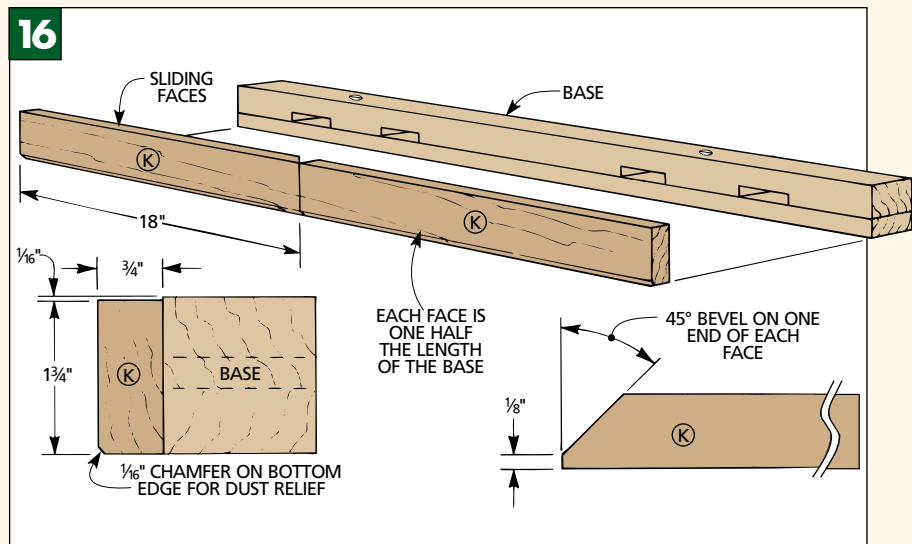
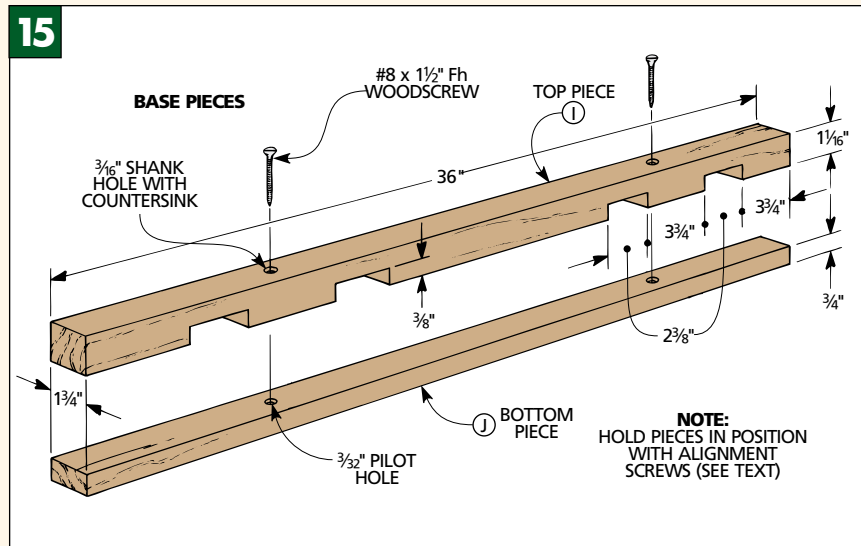

**36** (Shop Note: Two threaded inserts are installed in the back face of each sliding face. A threaded knob extends through each slot in the base into an insert. When tightened, the knobs pull the faces tight to the base and hold them in place.) To locate the position for the inserts, clamp the faces to the base with the bottom edges flush. The beveled edges of the faces should be in the closed position (ends touching); see Fig. 17. Then use an awl to scribe the locations of the slots onto the faces.

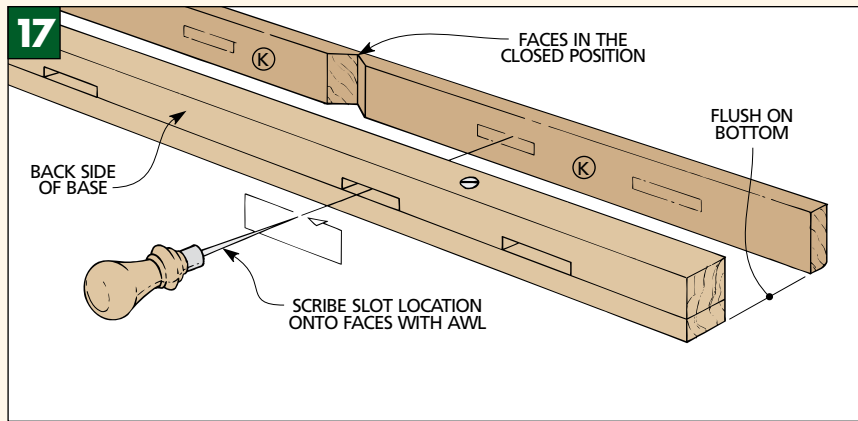

**37** Chuck a  $\frac{9}{16}$ " Forstner bit into your drill press. Drill a hole centered top to bottom in each slot outline and positioned at the end of the slot outline closest to the bevel; see Fig. 18. Don't drill completely through the sliding face. Drill only as deep as the insert.

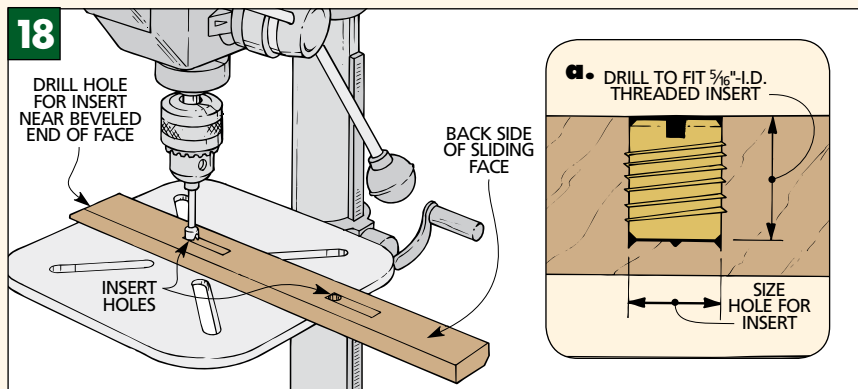

**38** Install the threaded inserts in the holes. See the box below.

## INSTALLING THREADED INSERTS

If you use your drill press to install the threaded inserts they will go in straight and square. Start by sawing off the head of a bolt that fits the insert. Next, thread two nuts and the insert onto the bolt, then tighten the nuts against the insert. Now chuck the bolt into the drill press. With the power off, turn the chuck clockwise by hand, using the control arm for downward pressure; see drawing. When the insert is in, loosen the nuts and back the bolt out of the insert.

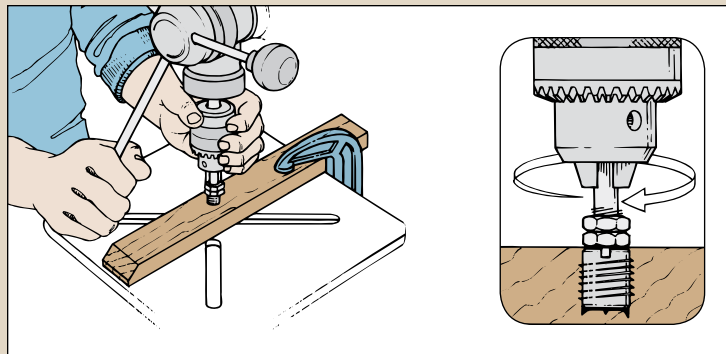

## Top Bar

**39** Cut two top bar halves (L) from  $\frac{3}{4}$ "-thick stock; see Fig. 19. The length of each piece is the same length as the base. To determine their width, add the width of the base to the thickness of the sliding face pieces; see Fig. 20a.

**40** Before assembling the two halves to make the top bar, cuts are made in each piece to form a T-slot in the finished top bar; see Fig. 19. First, cut a  $\frac{3}{8}$ "-wide groove  $\frac{3}{8}$ " deep in one face of each top bar half (L); see Fig. 19, Step 1. Then turn each piece on edge and trim  $\frac{1}{4}$ " off the tongue formed by the groove; see Fig. 19, Step 2.

**41** Just like when gluing up the base, drill two countersunk shank holes to allow you to screw the top bar halves together while gluing; see Fig. 19. Drill the holes from the underside of the top so they won't be visible. Then glue and screw the top bar halves together using #8 x  $\frac{1}{4}$ " Fh woodscrews.

**42** Before gluing the finished top bar (L) to the base, temporarily fasten the sliding face pieces (K) to the base using threaded knobs or bolts; see Fig. 20. Then with the sliding faces and T-slot facing down on a flat surface, clamp the base to the top bar. Make sure the pieces are square and the ends are flush. Again, drill two countersunk screw holes for #8 x  $2\frac{1}{2}$ " Fh woodscrews to help align the pieces during glueup. Drill from the underside of the base to hide the screws; see Fig. 20.

**43** Remove the sliding face pieces from the assembly. Then glue, screw, and clamp the top bar to the base.

**44** After the glue has dried, you can cut a 4"-wide opening in the base for the router bit; see Fig. 21. Center the opening on the length of the base. Make repeated passes over a dado blade to remove the waste. Be careful not to cut into the top bar.

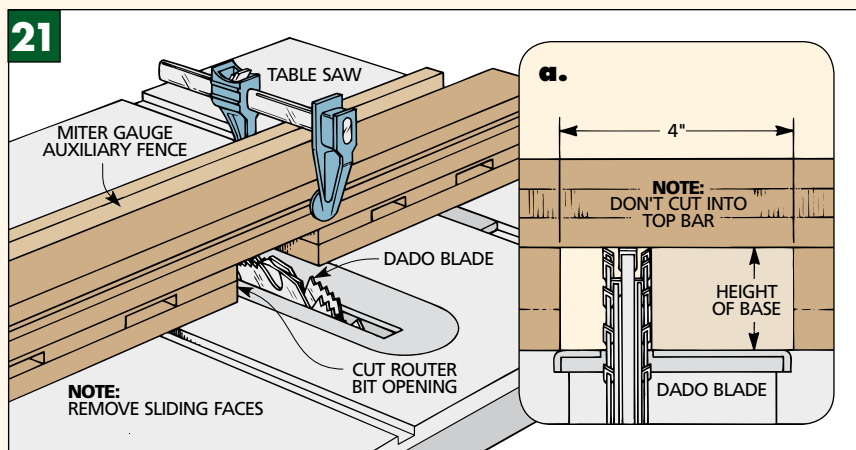
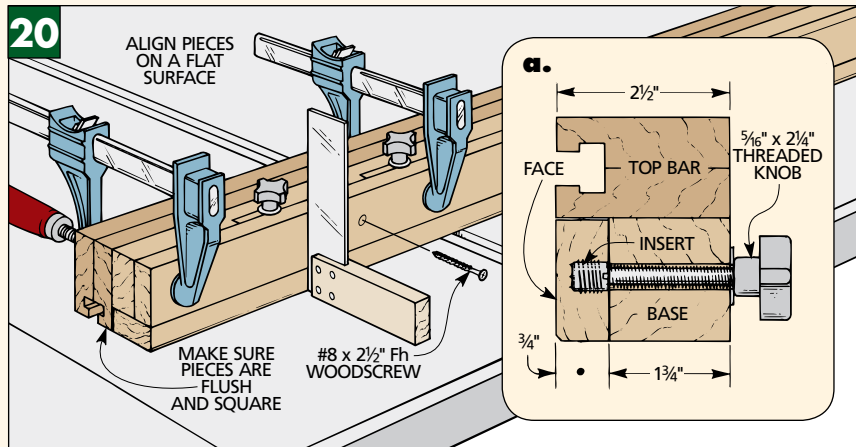
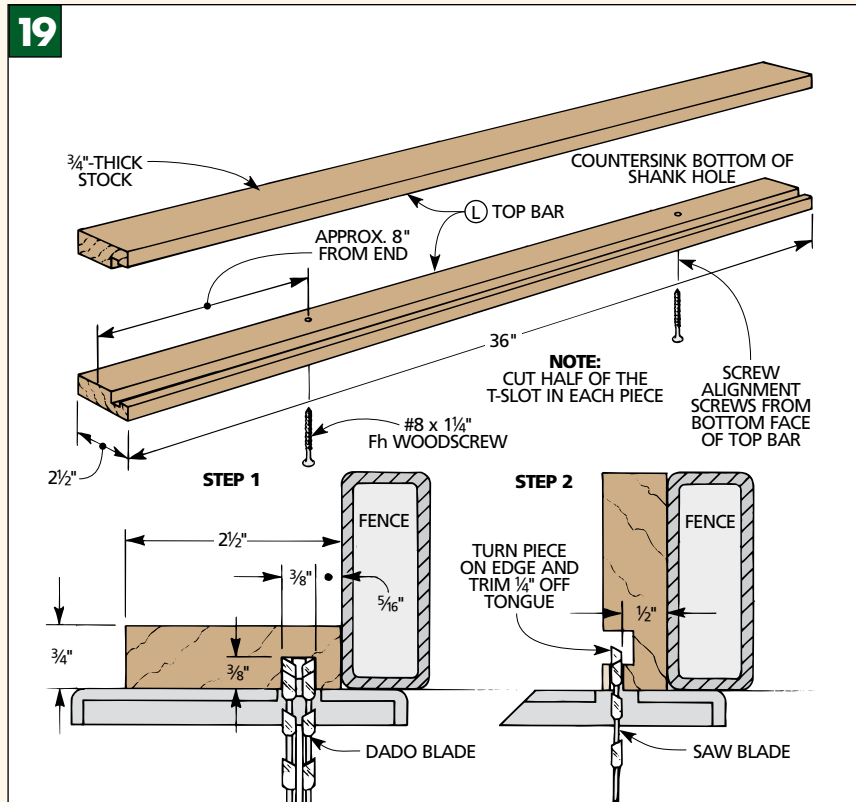

## Clamp System

**Shop Note:** A clamp assembly on each end of the fence holds the fence in place. A bolt extends through a clamp head and the fence; see Fig. 22. When the bolt is tightened, the fence is locked into place on the table top.

**45** Start by cutting an arm blank (M) from  $\frac{3}{4}$ " stock. Cut it the same width as the router table base and 8" long; see Fig. 23. (Shop Note: It's safer to make cuts on an oversized blank and then cut the blank to finished length.) A bevel cut on each end of the blank will improve the look of the clamp when it's finished.

**46** Cut spacers (N) to glue to each end of the arm blank; see Fig. 23. Their thickness is  $\frac{1}{8}$ " less than the thickness of the router table top. Their width is the same as the arm blank (M). To determine the spacer length, center the fence from side to side on the table top. Next, measure the amount of overhang on each side and subtract  $\frac{1}{8}$ " for clearance. Cut two spacers to these dimensions and glue them to the blank.

**47** After the blank dries, cut a  $\frac{3}{8}$ "-deep kerf  $\frac{1}{2}$ " from the end of each spacer; see Fig. 23. To do this, raise your table saw blade to  $\frac{3}{8}$ ". Then set up the rip fence as a stop and push the arm blank assembly through the blade using the miter gauge. While the saw is set up, cut matching kerfs in the bottom of the fence base; see Fig. 22.

### TIP

Make a test cut in scrap first to check that  $\frac{1}{8}$ " hardboard fits the kerf cut by your blade.

**48** Cut the arm blank in half to form the two clamp heads; see Fig. 23.

**49** Stick a clamp head to each end of the bottom of the fence using double-sided carpet tape; see Fig. 24. Then drill a  $\frac{3}{8}$ "-dia. hole through the clamp head and fence. If your drill bit is not

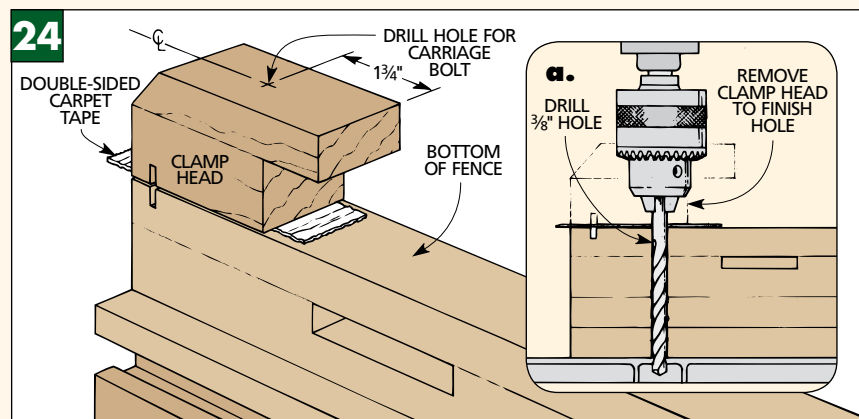
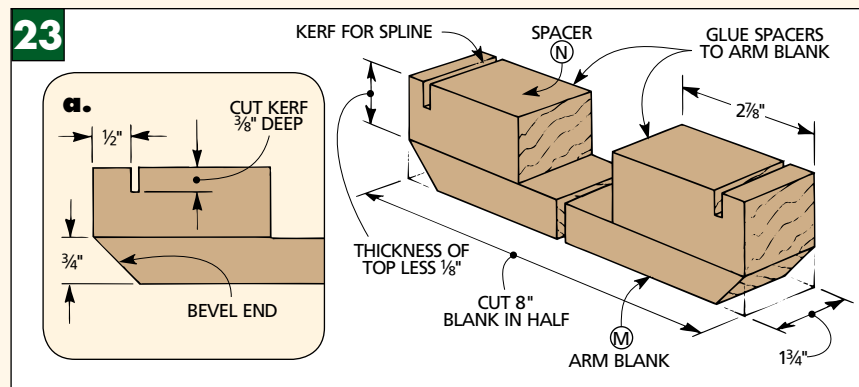
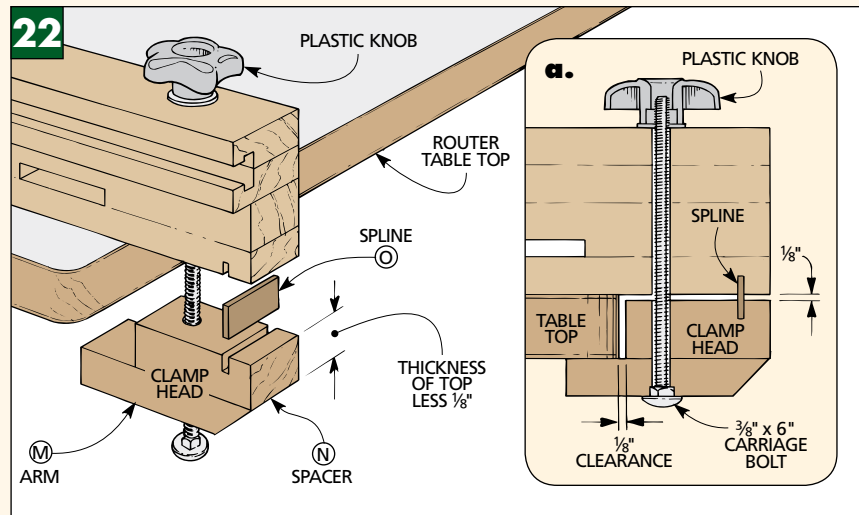

long enough to drill through both pieces at once, drill as deep as you can. Then remove the clamp head and continue on through the fence to finish the hole; see Fig. 24a.

**50** Cut two  $\frac{1}{8}$ "-thick hardboard splines (O) that are  $\frac{1}{8}$ " wider than the combined depth of the two kerfs and as long as the clamp head is wide; see Fig. 22.

**51** Place a spline in each clamp head, then align the spline with the kerf in the fence; see Fig. 22. Fasten each clamp head to the fence with a  $\frac{3}{8}$ " x 6" carriage bolt. Use plastic star knobs or wing nuts to tighten the carriage bolts.

**52** Apply a finish to the fence. The fence in the photo on page 8 was finished with two coats of tung oil.

# ENCLOSED BASE

The open-base router table shown on pages 1 and 3 is quick to build and will certainly do the job it was designed to do. However, if you'd like to show off a bit more craftsmanship, then build this enclosed base router table.

The table and fence are the same ones used on the open base table. The enclosed base, however, does offer some additional features.

By surrounding the router in a heavy box made of  $\frac{3}{4}$ " plywood,

you'll greatly reduce the noise generated by your router. And instead of having a pile of sawdust and chips at your feet, the enclosed box also helps contain the mess. A built-in dust collection box slides out easily to make cleanup a snap.

Your collection of bits is also close at hand with bit holders built right onto the doors. And in the bottom of the case, there's room to store your accessories.



## Construction Details

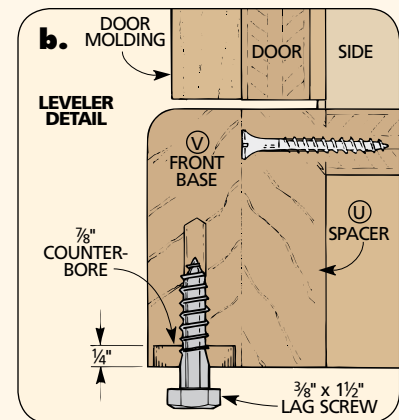
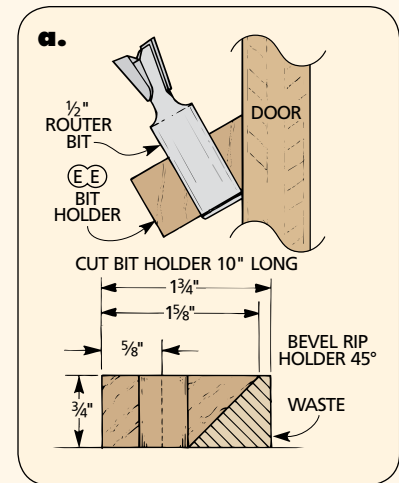
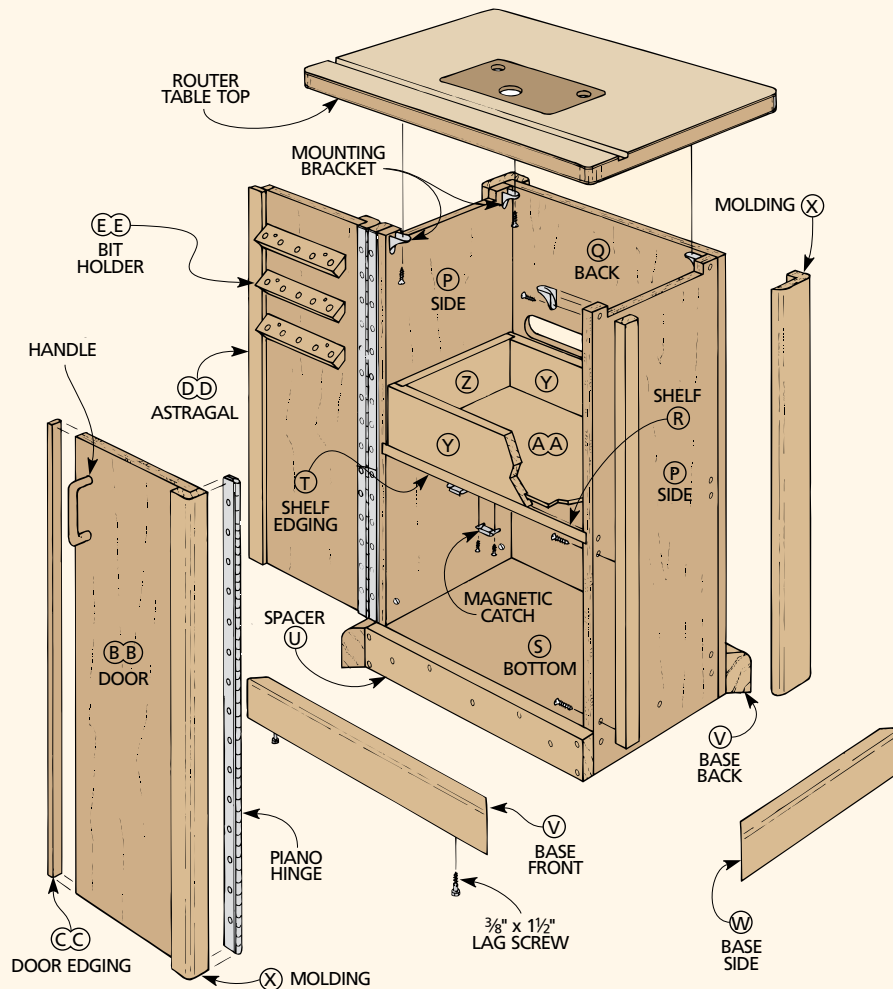

## MATERIALS

### WOOD

<b>P</b> Cabinet Sides (2)	$\frac{3}{4}$ ply - $14\frac{13}{16}$ x 35
<b>Q</b> Cabinet Back (1)	$\frac{3}{4}$ ply - $23\frac{1}{2}$ x 35
<b>R</b> Shelf (1)	$\frac{3}{4}$ ply - $14\frac{5}{16}$ x $22\frac{1}{2}$
<b>S</b> Cabinet Bottom (1)	$\frac{3}{4}$ ply - $14\frac{13}{16}$ x $22\frac{1}{2}$
<b>T</b> Shelf Edging (1)	$\frac{1}{2}$ x $\frac{3}{4}$ - $22\frac{1}{2}$
<b>U</b> Spacer (1)	$\frac{15}{16}$ x $3\frac{1}{2}$ - $23\frac{1}{2}$
<b>V</b> Base Front/Back (2)	$1\frac{1}{16}$ x $3\frac{1}{2}$ - $25\frac{5}{8}$
<b>W</b> Base Sides (2)	$1\frac{1}{16}$ x $3\frac{1}{2}$ - $18\frac{5}{8}$
<b>X</b> Molding (4)	$1\frac{1}{2}$ x 3 - $31\frac{1}{2}$
<b>Y</b> Dust Box Fr./Bk (2)	5 x $2\frac{17}{8}$ - $\frac{3}{4}$ ply
<b>Z</b> Dust Box Sides (2)	5 x 14 - $\frac{3}{4}$ ply
<b>AA</b> Dust Box Bottom (1)	$\frac{1}{4}$ ply - $13\frac{1}{2}$ x $20\frac{7}{8}$
<b>BB</b> Doors (2)	$\frac{3}{4}$ ply - $11\frac{3}{16}$ x $31\frac{3}{8}$
<b>CC</b> Door Edging (2)	$\frac{1}{2}$ x $\frac{3}{4}$ - $31\frac{3}{8}$
<b>DD</b> Astragal (1)	$\frac{3}{16}$ x $\frac{7}{8}$ - $31\frac{3}{8}$
<b>EE</b> Bit Holders (6)	$\frac{3}{4}$ x $1\frac{5}{8}$ - 10

### HARDWARE

- (57) #8 x  $1\frac{1}{4}$ " Fh woodscrews
- (6) #8 x  $1\frac{1}{2}$ " Fh woodscrews
- (4)  $\frac{3}{8}$ " x  $1\frac{1}{2}$ " lag screws
- (12) 4d ( $1\frac{1}{2}$ " ) finish nails
- (2) D-handle pulls with machine screws
- (2) 36" piano hinge
- (2) Magnetic catches and strikes

## CUTTING DIAGRAM

$1\frac{1}{16}$ " x 8" - 48" (TWO BOARDS @ 2.5 BD. FT. EACH)

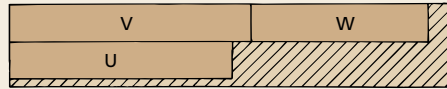

ALSO NEED  
 $13\frac{1}{2}$ " x  $20\frac{7}{8}$ "  
PIECE OF  $\frac{1}{4}$ "  
PLYWOOD FOR  
DUST BOX BOTTOM

$1\frac{1}{2}$ " x 4" - 72" (TWO BOARDS @ 4 BD. FT. EACH)



$\frac{3}{4}$ " x 4" - 72" (2 BD. FT.)



1 SHEET (48" x 96") OF  $\frac{3}{4}$ "-THICK PLYWOOD

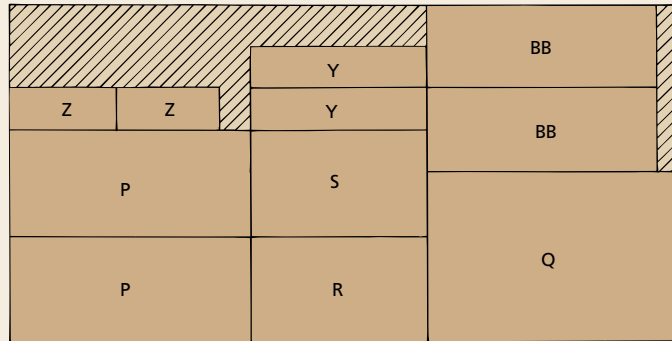

## Case

**1** To begin building the case of the open-base router table, cut a 35"-long piece off the end of a sheet of  $\frac{3}{4}$ "-thick plywood. This is for the cabinet sides (P) and dust box sides (Z); see the Cutting Diagram. Then rip a blank for both cabinet sides (P) from this piece to a rough width of 31".

**2** Cut two  $\frac{1}{4}$ "-deep dadoes across the blank; see Fig. 1. The first, for the bottom (S), is  $3\frac{1}{2}$ " from the bottom of the blank. The second, for the shelf (R), is 18" from the bottom. These dadoes are as wide as the thickness of the plywood.

**3** Once the dadoes are cut, rip the sides (P) to a finished width of  $14\frac{13}{16}$ ".

**4** Cut the back (Q), shelf (R) and bottom (S) to size from  $\frac{3}{4}$ " plywood; see Cutting Diagram and Fig. 1.

**5** To cover the exposed plies on the shelf, cut a  $\frac{3}{4}$ "-wide shelf edging (T) from  $\frac{1}{2}$ "-thick stock. The edging strip should cover the full length of the shelf. Glue the edging strip to the shelf.

**6** To improve airflow into the router, cut a  $\frac{1}{2}$ "-wide notch along

the top of each side (P); see Fig. 1a. Stop the slot  $1\frac{1}{2}$ " from each end. Also cut a  $1\frac{3}{4}$ "-wide slot,  $19\frac{1}{2}$ " long, in the cabinet back (Q); see Figs. 1 and 1b. The slot is stopped 2" from each edge of the back. The top edge of this slot should be 10" from the top edge of the back.

**7** Dry assemble the cabinet sides, shelf, back, and bottom. Drill and countersink  $\frac{3}{16}$ " shank holes and  $\frac{3}{32}$ " pilot holes at the locations shown in Fig. 2. Double check the case for square, then glue and screw the case together with #8 x  $1\frac{1}{4}$ " Fh woodscrews.

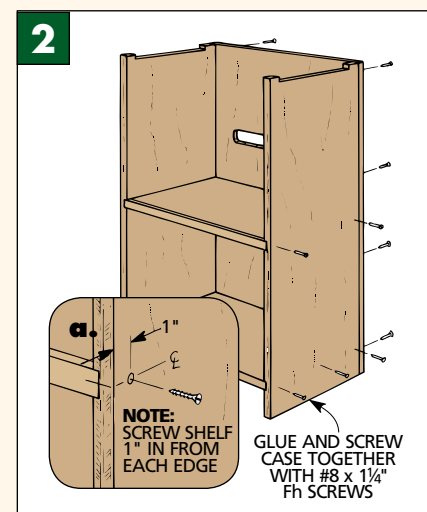
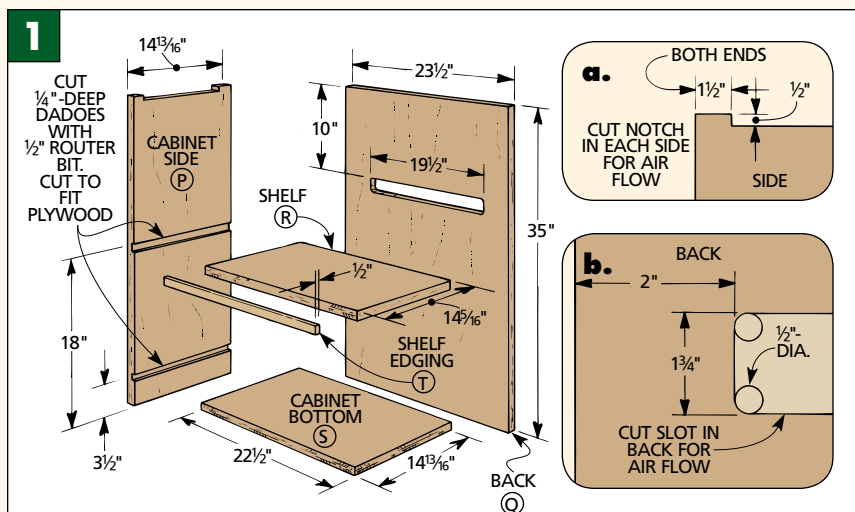

## Base

**8** Plane a piece of  $1\frac{1}{16}$ "-thick stock down to  $\frac{15}{16}$ " thick for a base spacer (U). Then cut it to a width of  $3\frac{1}{2}$ " and a length of  $23\frac{1}{2}$ "; see Fig. 3. Drill countersunk shank holes as shown in Fig. 3a. (The three shank holes along the center of the spacer are used later to attach a base piece. These holes are countersunk on the back side.) Drill pilot holes into the case. Then glue and screw the spacer to the bottom front of the case using #8 x  $1\frac{1}{2}$ " Fh woodscrews; see Figs. 3 and 3b.

**9** Cut two front/back base pieces (V) from  $1\frac{1}{16}$ "-thick stock to a finished width of  $3\frac{1}{2}$ " and a rough length of  $27\frac{1}{2}$ "; see Fig. 3. Cut two side base pieces (W) from  $1\frac{1}{16}$ "-thick stock to a finished width of  $3\frac{1}{2}$ " and a rough length of  $21\frac{1}{2}$ ".

**10** Use a  $\frac{1}{2}$ " roundover bit to round over the top edge of each base piece (V, W); see Fig. 3b.

**11** Now miter the four base pieces to fit around the bottom of the cabinet; see Fig. 3.

**12** (Shop Note: Two lag screws are installed in each of the front and back base pieces to serve as levelers; refer to Detail 'b' on page 12.) First, use a  $\frac{7}{8}$ " Forstner bit to drill two  $\frac{1}{4}$ "-deep counterbores on the bottom edge of the front and back base pieces. This counterbore allows you to adjust the lag screw with a socket wrench. Center the counterbores on the thickness of the base pieces  $1\frac{1}{2}$ " from each end. Then drill a  $\frac{1}{4}$ "-dia. pilot hole  $1\frac{1}{2}$ " deep, centered in each counterbore. Finally, install a  $\frac{3}{8}$ " x  $1\frac{1}{2}$ " lag screw in each hole.

**13** Turn the case upside down. Then clamp the base pieces in place. Drill three evenly-spaced shank holes from

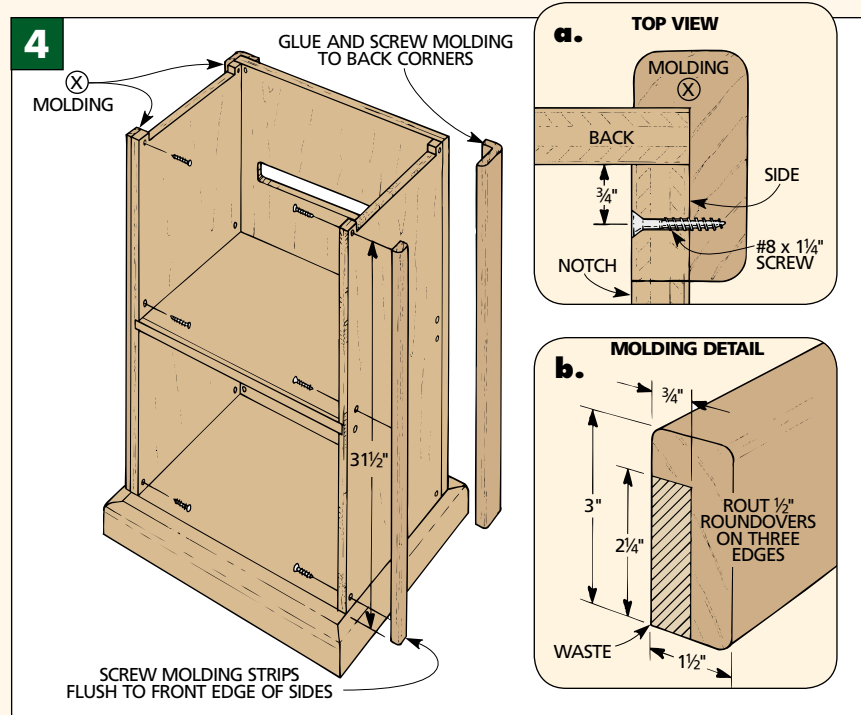
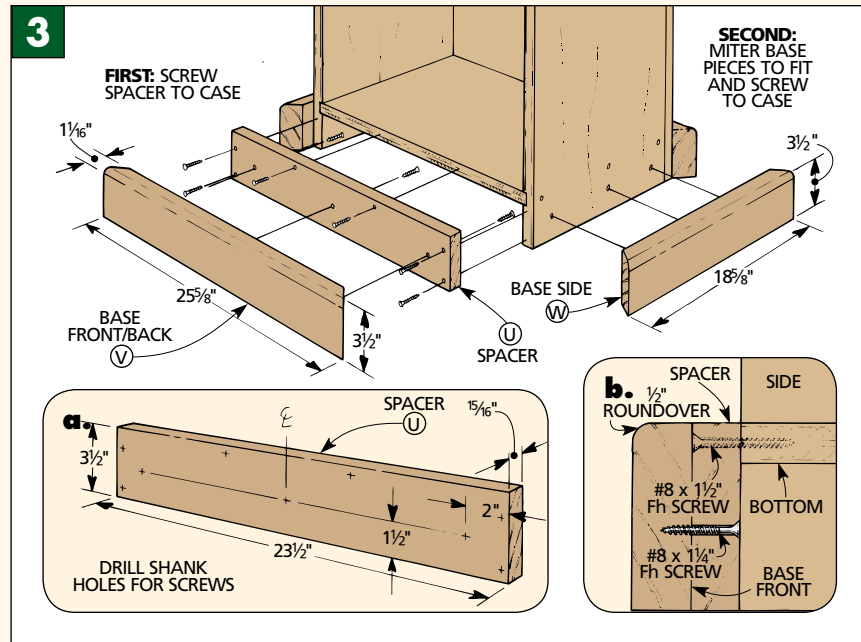

the inside face of the case sides and back; see Fig. 3. Next, drill pilot holes into all four base pieces. Finally, glue and screw the base pieces in place using #8 x  $1\frac{1}{4}$ " Fh woodscrews.

## Molding

**14** Cut four molding strips (X) from  $1\frac{1}{2}$ "-thick hardwood to a width of  $3$ ". To determine their length, measure from

the top of the base pieces (V, W) to the top of the case sides; see Fig. 4.

**15** Rout  $\frac{1}{2}$ " roundovers on three edges of each strip; see Fig. 4b.

**16** On the table saw, cut a  $2\frac{1}{4}$ "-wide rabbet  $\frac{3}{4}$ " deep to remove the remaining square corner from each piece of molding; see Fig. 5.



**17** The molding strips (X) for each door wrap around the hinged side of the door onto the side of the case, so the molding must be cut into two pieces. To do this, rip two pieces of molding so the remaining rabbet is the thickness of the plywood; see Fig. 6. Set aside the two narrow molding pieces with the rabbet. They will be attached to the doors later.

**18** To begin mounting the molding to the case, first drill countersunk shank holes through the case sides from the inside; see Fig. 4. Then clamp the molding in place. (The full corner moldings go on each back corner, with the wide face on the side of the cabinet; see Fig. 4a. The flat strips ripped from the front moldings mount flush with the front edge of the cabinet side; see Fig. 6a.) Drill pilot holes into the molding. Be careful not to drill through the outside face of the molding. Then glue and screw the molding to each corner with #8 x 1 1/4" Fh woodscrews.

## Dust Box

**19** Cut a dust box front and back (Y) from 3/4" plywood; see Fig. 7. These pieces are both 5" wide with a length 1/8" less than the inside width of the cabinet.

**20** Cut two sides (Z) from 3/4" plywood. These pieces are both 5" wide and 14" long; see Fig. 7.

**21** Cut a 3/4"-wide rabbet 1/2" deep across each end of the front and back pieces (Y); see Fig. 7a.

**22** To hold the plywood bottom (AA), cut a 1/4"-deep groove 3/4" from the bottom edge of each of the dust box pieces (Y, Z). The width of the groove should fit the thickness of the plywood to be used for the bottom; see Fig. 7b. This groove can be made with a dado blade or by making two passes over a regular saw blade.

**23** To determine the size of the bottom (AA), dry assemble the dust box. Measure the inside dimensions

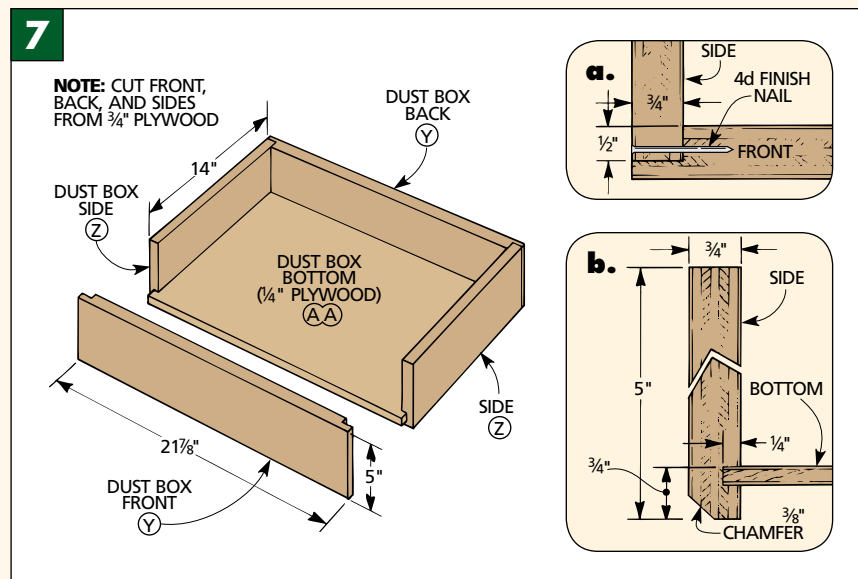
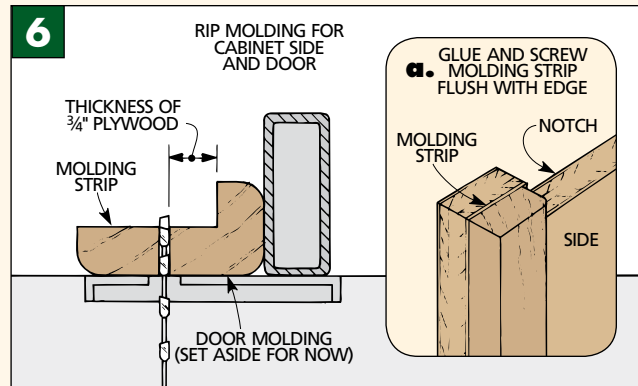
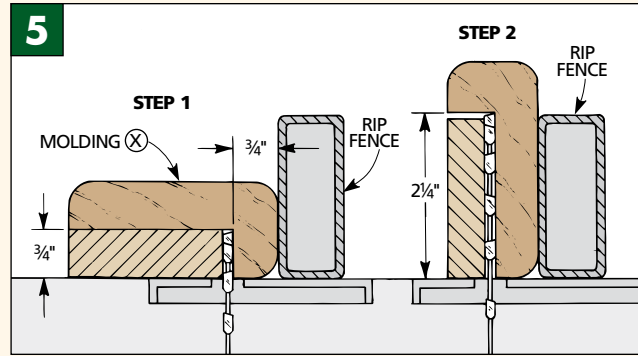

and add 7/16" to each measurement to account for the grooves. Cut the bottom from 1/4" plywood.

**24** Assemble the dust box with the bottom. Glue and nail it together using 4d (1 1/2") finish nails; see Fig. 7a.

**25** After the dust box is assembled, rout 3/8" chamfers along the bottom edges; see Fig. 7b. This allows the box to slide in and out of the case easily.

## TIP

While the box is dry assembled, double check the fit of the dust box into the case. The front of the dust box should set flush with or slightly behind the front edges of the case and the shelf. Otherwise, the doors won't close.

## Doors

**26** Start making the doors (BB) by measuring the front of the case from outside edge to outside edge (do not include the molding). Then subtract 1" from this measurement to allow for the 1/2"-thick edging strips applied later to each door. This will be the width of a door blank big enough for both doors. Then measure from the top of the base (V) to the top of the case and subtract 1/8" for clearance. This will be the length of the door blank. Cut the door blank to these dimensions from 3/4" plywood.

**27** Now rip the door blank in half to leave two doors (BB) of equal width.

(Shop Note: This rip also creates the 1/8" gap you need between the doors after they are mounted to the case; refer to Fig. 12.)

**28** Cut two 1/2"-thick edging strips (CC) to mask the plies on the long edge of the door; see Fig. 8. Their width equals the thickness of the door (BB); see Fig. 8a. The edging strips should be the same length as the doors. Glue an edging strip in place on the inside edge of each door.

**29** Next, install the molding (X) set aside earlier on the outside edge of each door; see Fig. 8b. To do this,

drill countersunk shank holes from the back side of each door centered 3/8" from the outside edge. Clamp the molding in place and drill pilot holes into the molding. Then glue and screw a molding strip to each door using #8 x 1 1/4" Fh woodscrews.

**30** An astragal (DD) attached to the left door helps contain dust and noise; see Fig. 9. Cut the astragal from 3/16"-thick stock to a width of 7/8" and the same length as the left door. Glue and clamp the astragal to the back of the edging on the left door; see Fig. 9.

**31** Drill mounting holes on each door for the handles; see Fig. 9. Then mount the handles.

**32** Cut two lengths of piano hinge the same length as the doors. Screw one flap to the door molding; see Fig. 10. Then, before screwing the other flap to the molding on the side of the case, put a 1/16"-thick spacer under the door to provide clearance; see Fig. 10.

**33** Mount the magnetic door catches and strikes; see Figs. 11 and 12.

### TIP

You may also want to add a nail to the inside of the case for hanging your router wrenches.

**34** Turning the router on and off is much easier if you add a switched outlet or a power strip with a switch to the case; see photo on page 1. If you aren't comfortable doing electrical work, consult a licensed electrician.

**35** Apply a finish to the case. The cabinet in the photo has two coats of an oil/varnish combination.

**36** Now build the table top and fence as instructed in Steps 11–52 beginning on page 4.

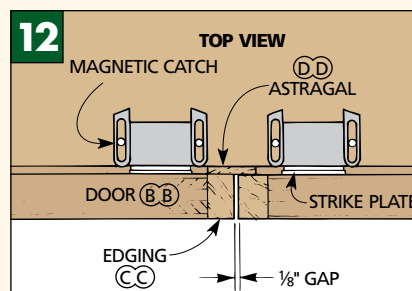
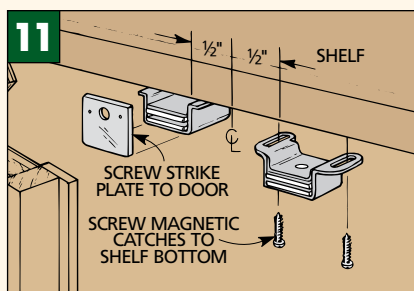
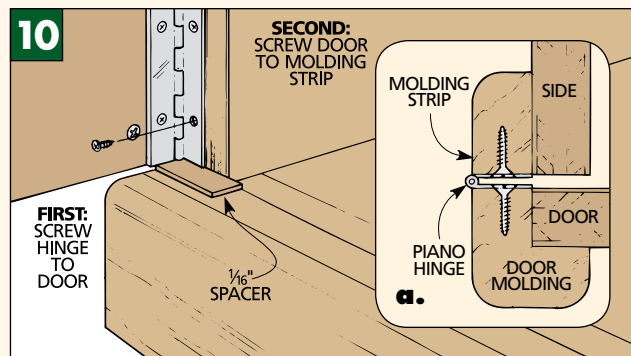
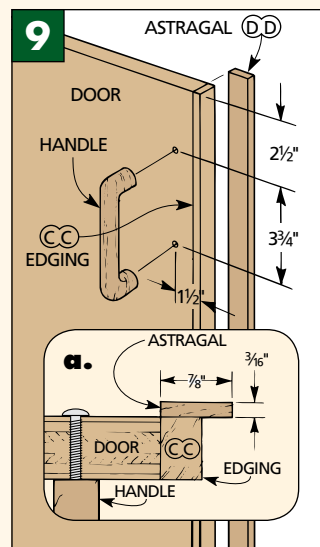
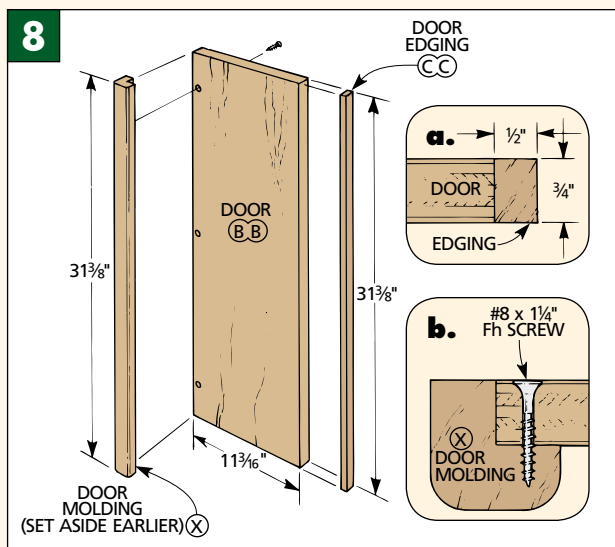

# SAFETY ACCESSORIES

Make safety a top priority with these accessories you can make yourself.

## Router Bit Guard

This bit guard attaches to the T-slot in the fence. It adjusts up and down to accommodate the thickness of your stock. The clear acrylic shield lets you see the bit. If you don't have T-slot nuts, the head of a toilet flange bolt will fit into the T-slot. (You may have to cut the bolts to length.) Then use wing nuts to secure the guard to the fence.



### MATERIALS

- (1 pc.) 1/2" hardwood - 3 1/2" x 7 1/2" x 4"
- (1 pc.) 1/4" clear acrylic plastic 2 1/2" x 4"
- (2) #8 x 3/4" Fh woodscrews
- (2) T-slot nuts (or toilet bolts)
- (2) 1" threaded knobs (or wing nuts)
- (2) Washers to fit knobs

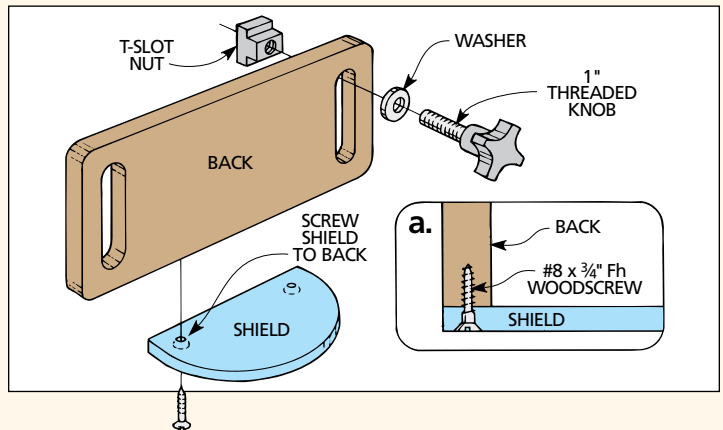
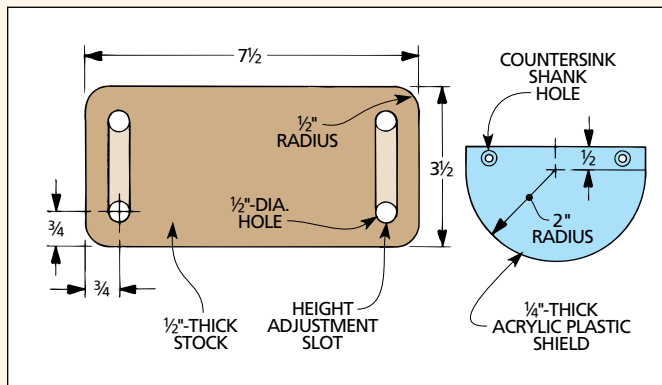

## Guard for Freehand Routing

For freehand routing, you may need more room between the fence and the bit. The clear acrylic guard shown in the photo at right screws to the bottom of the fence, then is held in place by the sliding faces of the fence. The opening in the fence allows chips to be drawn away if you attach a vacuum hood to the back of the fence.



### MATERIALS

- (1 pc.) 1/4" clear acrylic plastic - 4" x 10"
- (2) No. 6 x 3/4" Ph sheet-metal screws
- (2) Washers to fit screws

