



THANK YOU!

You have successfully downloaded your *Woodsmith* project plan.

▶ [Go to Page 1](#)

Get More from Your Table Saw...at PlansNOW.com



Build our 10 BEST Table Saw Jigs!

What really makes a table saw so versatile are the jigs and accessories that improve your saw's overall performance.

▶ [Download Today at PlansNOW.com...\\$4.95](#)

Woodsmith Shop TV Show Special...Save 10%



Use Coupon Code *TVSHOW* at PlansNOW.com

Visit PlansNOW.com today and save 10% on more than 200 woodworking plans and how-to technique articles.

▶ [Go to PlansNOW.com Now](#)

You Can Build It...at PlansNOW.com



Workbenches

Good woodworking starts with a solid workbench.



Shop Jigs & Techniques

Get the most from your tools with easy-to-build shop jigs.



Cabinets & Shelves

Build stunning furniture that's both functional and beautiful.



Home Improvement

Save hundreds of dollars in remodeling when you DIY.



Woodsmith **PLANS**

ROLL-AROUND TOOL BASE



ROLL-AROUND TOOL BASE

With this easy-to-build roll-around tool base, moving a heavy power tool isn't a back-breaking experience.

Even though most stationary power tools come with legs, they certainly can't walk. So when it comes time to move one around, you're faced with a dilemma.

You could take the brute force approach. But you'll probably end up with a sore back and a tool that has been jostled out of alignment.

A better solution is to use a roll-around tool base, like the one shown at right. This way, just about any stationary tool can be moved without much effort.

SMALL SHOP. A roll-around tool base is especially useful in a small shop where tools are rolled out of the way when they aren't in use. Or when a tool needs to be moved for a specific cut (like ripping a long board or crosscutting plywood).

TWO PARTS. The tool base consists of two main parts: a base for the tool to sit in and a handle to raise



the base onto wheels so it can be towed around, see photo on next page. A simple hardware "hitch" connects the two parts and lets you turn a tool on a dime.

BASE

I started by building the base that the tool sits in. It's just a 2x4 frame with a plywood bottom. The frame is screwed together with lags.

HARDWARE

- (4) 2" Rigid Casters, with Screws
- (1) 5/16" x 5" Screw Hook
- (8) 1/4" x 3 1/2" Lag Screws
- (8) 1/4" Washers
- (1) 5/16" x 1 3/4" U-bolt, with Plate and Nuts
- (2) 5/16" Washers
- (2) 5/16" Nuts
- (20) #8 x 1" Fh woodscrews

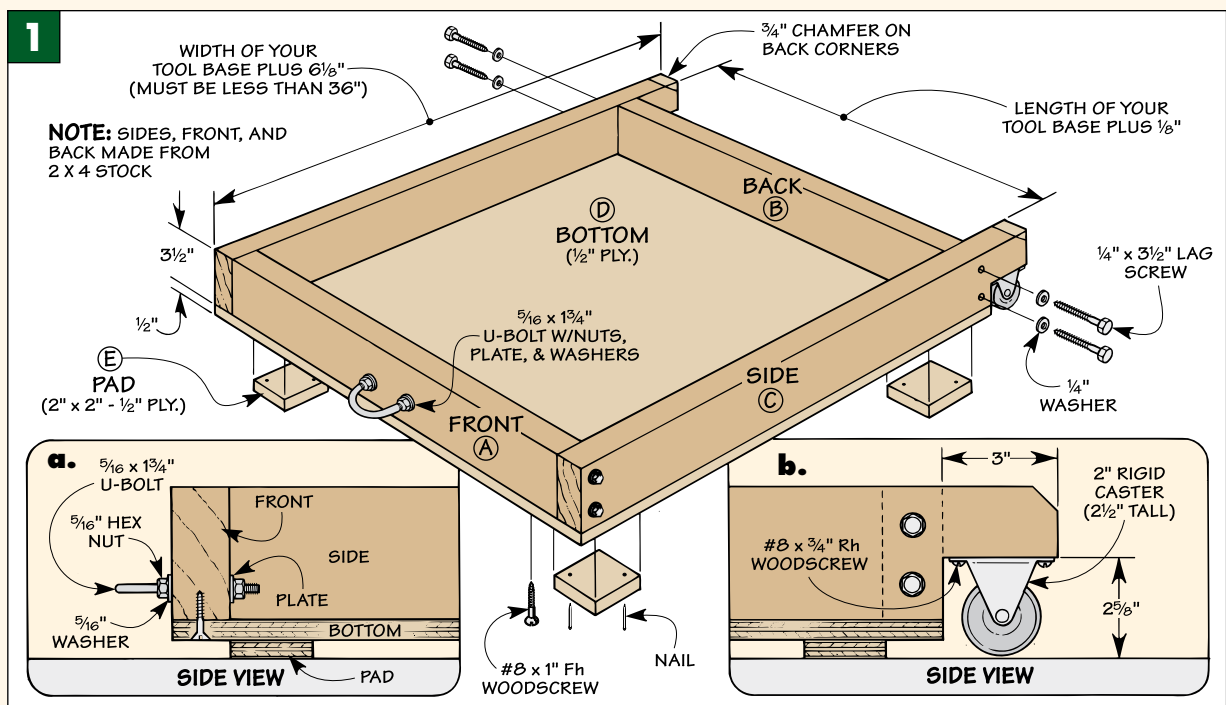

FRAME. The frame is sized to fit around the base of the tool, see photo on previous page. The length of the front (A) and back (B) equals the outside distance of the legs at the widest point — plus $\frac{1}{8}$ " for clearance, see Fig. 1.

Determining the length of the frame sides (C) is a bit trickier. After measuring the front-to-back distance of your tool's legs or base, add $6\frac{1}{8}$ ". (This provides an $\frac{1}{8}$ " clearance for the tool legs, 3" for the front and back frame pieces, and 3" for the wheels.)

Design Note: In order for the back wheels to ride on the floor when the base is raised, the sides must be less than 36" long.

BOTTOM. After screwing the frame together, a bottom (D) can be cut to fit from $\frac{1}{2}$ " plywood and screwed to the frame, see Fig. 1.

Next, to help stabilize the base whenever it's positioned on an uneven floor, glue and nail four $\frac{1}{2}$ "-thick plywood pads (E) to the bottom (D), see Fig. 1.

WHEELS. Now the wheels can be added to the base. To do this, you'll first need to cut a notch at the end of each side (C), see Fig. 1b.

NOTCH. It's the size of this notch that allows the base to work. By making it $\frac{1}{8}$ " taller than the wheels, the wheels stay off the floor until the front is raised with the handle.

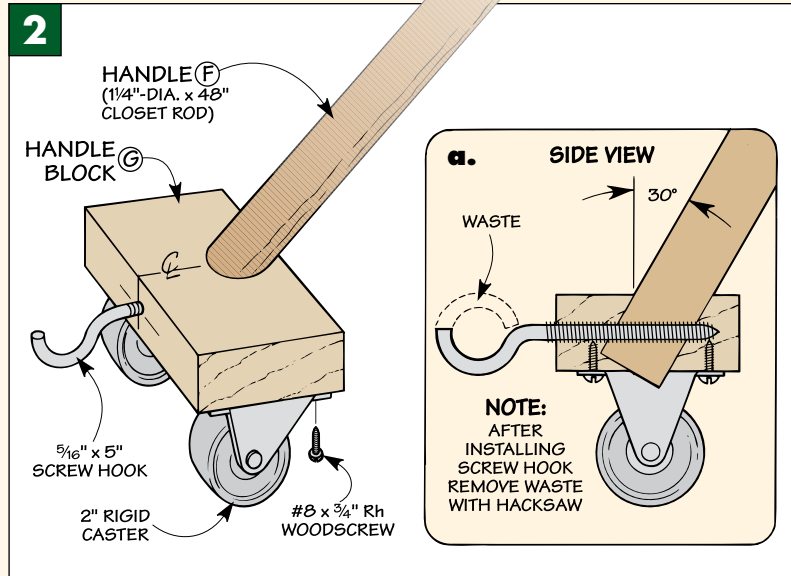

When the front is raised, this $\frac{1}{8}$ " gap is quickly closed. The wheels come in contact with the floor, and you're rolling, see photo below.

You can use a jig saw or hand saw to cut the notch. Just make sure to keep the cut as square as possible so the wheels ride flat on the floor.

To complete the base, a U-bolt that hitches the handle to the base is bolted to the front frame piece (A), see Fig. 1a.

HANDLE

All that's left to make is the handle that's used to tow the base.

DOWEL. The handle (F) is a four-foot length of closet rod (available

at most lumber yards), see Fig. 2. It fits into a handle block (G) made from a scrap of 2x4.

To drill the hole for the rod, I used a $1\frac{1}{4}$ " Forstner bit and tilted the table top on my drill press to 30° , see Fig. 3.

The next step is to drill a $\frac{5}{16}$ " dia. hole through the handle block and the rod for a screw hook, refer to Fig. 2. This hook locks the handle into the handle block and allows you to "latch" onto the U-bolt in the base to tow it around.

WHEELS. Finally, attach a set of casters to the bottom of the handle block, see Fig. 2a. Then take your tool for a spin around the shop.

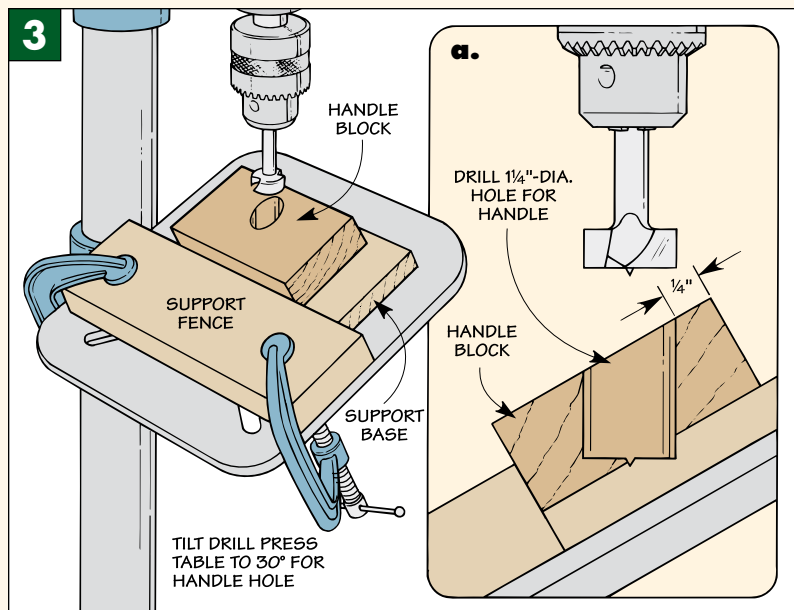

▲ **Easy Lifting.** Leverage and this simple hardware hitch (consisting of a U-bolt and a screw hook) are all that's required to lift a heavy power tool and maneuver it around when you're in a tight space.